

Dual-Frequency Identification Sonar DIDSON

Operation Handbook

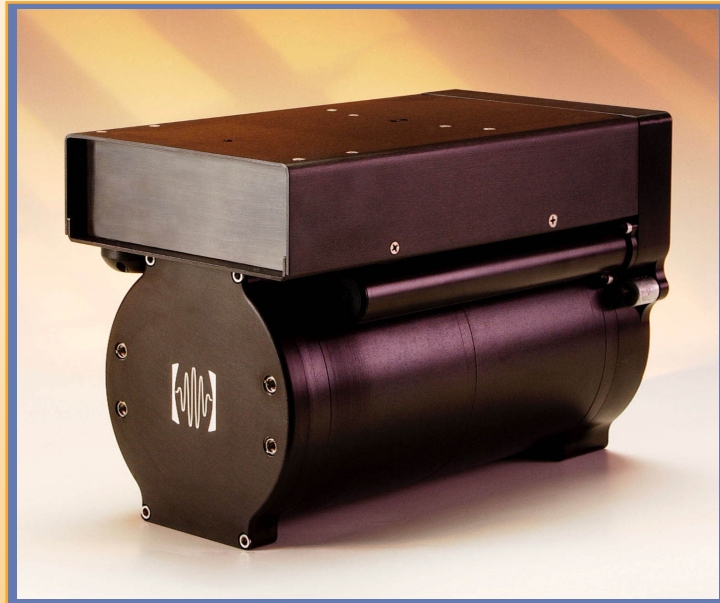

Standard DIDSON

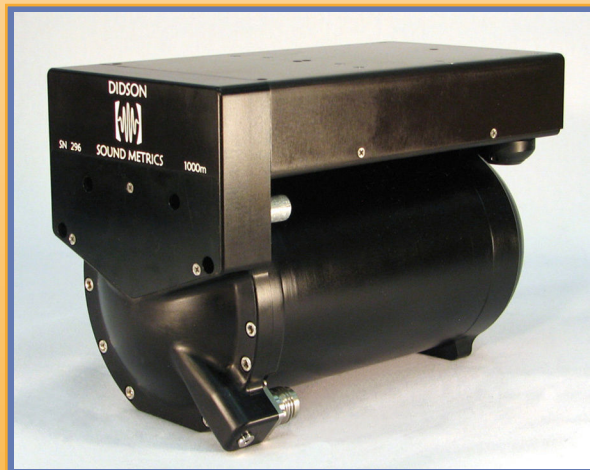

1000m DIDSON

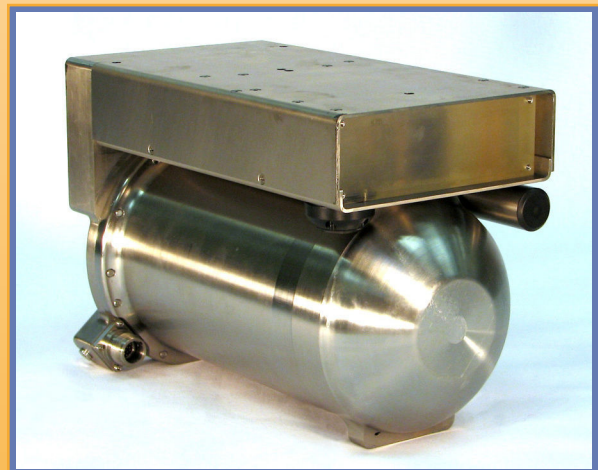

3000m DIDSON



www.soundmetrics.com

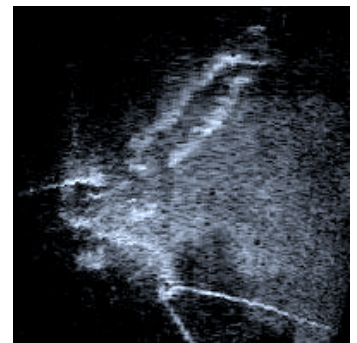
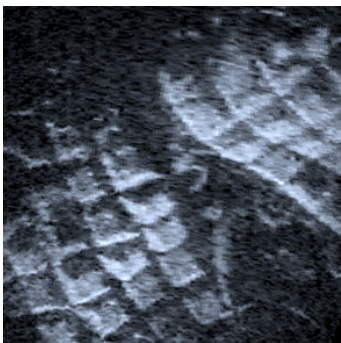
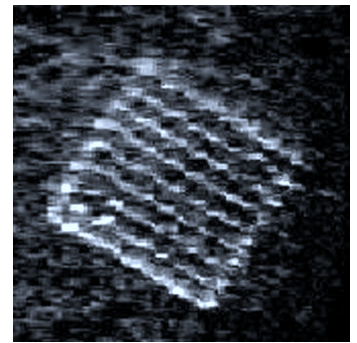
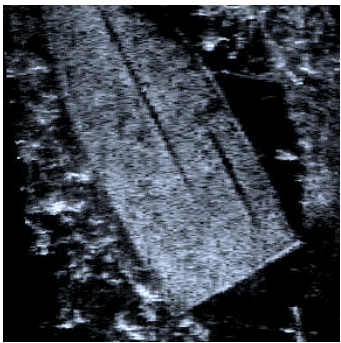
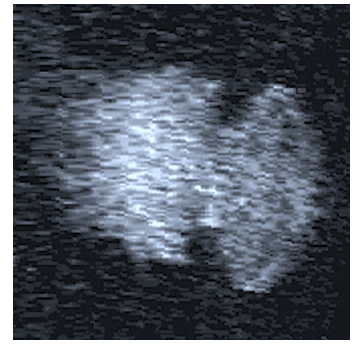
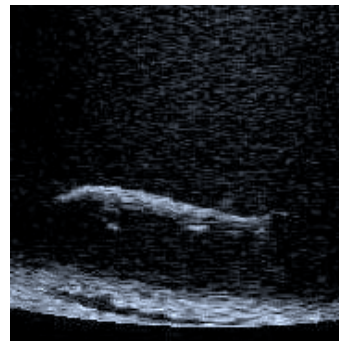
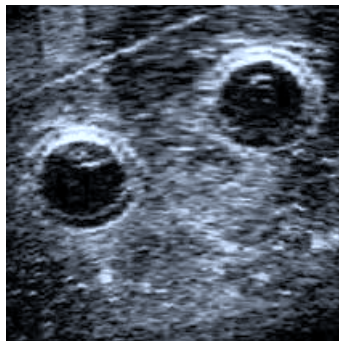
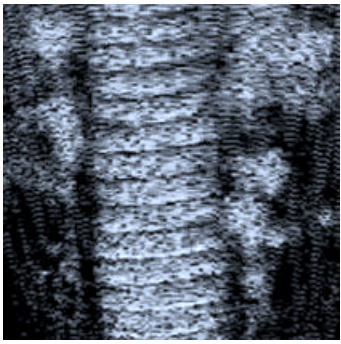
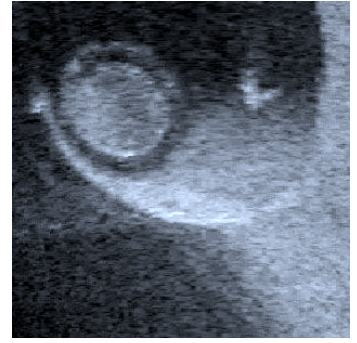
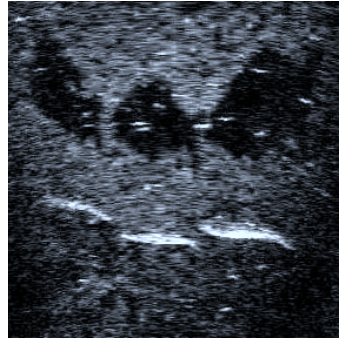
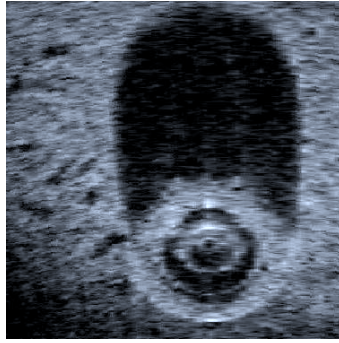
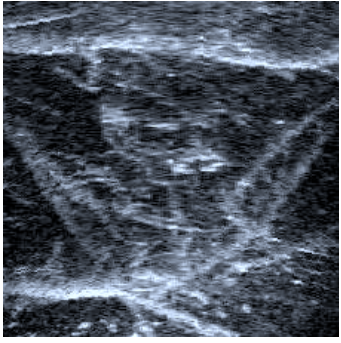
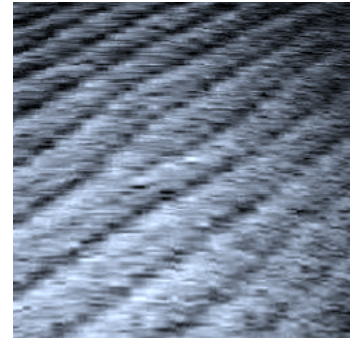
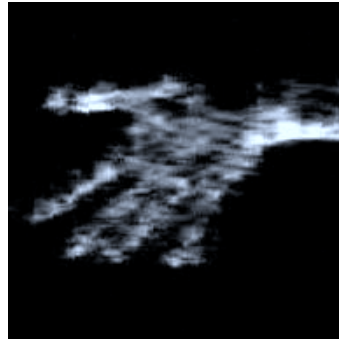
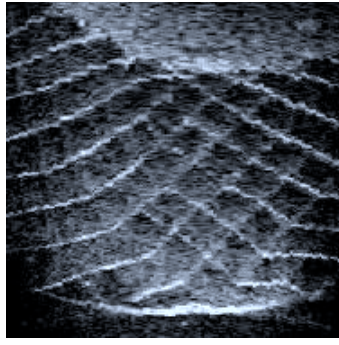
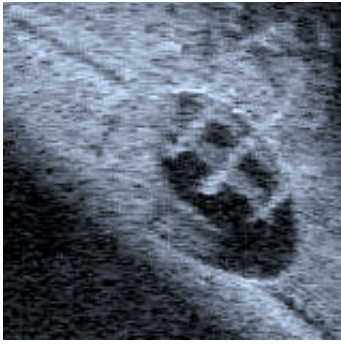

Manufacturer

Sound Metrics Corporation
15029 Bothell Way NE, Suite 100
Lake Forest Park, WA 98155
Office: 206/364.1441
Fax: 206/374.2929

Distributor

Ocean Marine Industries Inc.
2810 Hudson Street
Chesapeake, VA 23324
Office: 757/382.7616
Fax: 757/382.5012

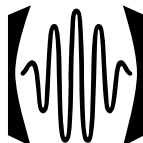

| | | |
|-----------|--|-----------|
| 1 | INTRODUCTION | 2 |
| 2 | WHAT IS A DIDSON? | 2 |
| 2.1 | AIMING THE DIDSON | 3 |
| 2.2 | SONAR MOVEMENT AFFECTS IMAGE | 4 |
| 2.3 | MOUNTING THE DIDSON FOR OPTIMUM DATA COLLECTION | 4 |
| 2.4 | BOTTOM MOUNT | 4 |
| 2.5 | POLE MOUNT | 4 |
| 2.6 | ROV MOUNT | 5 |
| 3 | SOFTWARE INSTALLATION | 6 |
| 4 | CONNECTING THE COMPONENTS | 6 |
| 4.1 | BASIC CONNECTION WITH SONAR CABLE 500 FEET OR LESS (PREVIOUSLY 200 FEET OR LESS) | 6 |
| 4.2 | BASIC CONNECTION WITH SONAR CABLE GREATER THAN 500 FEET (PREVIOUSLY GREATER THAN 200 FEET) | 8 |
| 5 | OPERATION OF THE DIDSON | 11 |
| 5.1 | TURN ON THE SONAR | 11 |
| 5.2 | A FEW COMMANDS FOR OPERATION | 11 |
| 5.3 | TURN OFF THE SONAR | 13 |
| 5.4 | USEFUL FACTS | 13 |
| 6 | MAINTENANCE | 14 |
| 6.1 | CLEANING THE LENSES | 14 |
| 6.2 | CLEANING THE FOCUS MECHANISM | 14 |
| 6.3 | REMOVE THE BUBBLE IN THE FRONT LENS | 15 |
| 6.4 | CLEAN AND LUBRICATE THE CONNECTORS | 16 |
| 6.5 | ZINC ANODES | 16 |
| 7 | SOFTWARE/FIRMWARE UPGRADES | 16 |
| 8 | TROUBLESHOOTING | 17 |
| 8.1 | SOFTWARE WILL NOT INSTALL | 17 |
| 8.2 | INTERMITTENT OR NO ETHERNET CONNECTION TO THE SONAR | 17 |
| 8.2.1 | <i>Application set to DEMO mode</i> | 17 |
| 8.2.2 | <i>Disable firewall</i> | 17 |
| 8.2.3 | <i>Data rate set too high</i> | 17 |
| 8.2.4 | <i>Patton Ethernet Extenders</i> | 17 |
| 9 | OPTIMIZING/CUSTOMIZING SONAR PARAMETERS | 18 |
| 10 | CONTACT INFORMATION | 18 |
| 11 | SPECS AND MECHANICAL DRAWINGS | 19 |
| 11.1 | SPECIFICATIONS - STANDARD DIDSON MODELS | 19 |
| 11.2 | SPECIFICATIONS - LONG RANGE DIDSON MODELS | 20 |
| 11.3 | WEIGHT AND DIMENSIONS SUMMARY FOR EACH MODEL | 20 |
| 11.4 | MECHANICAL DRAWING FOR THE STANDARD DIDSON 300M FORWARD FACING CONNECTOR | 21 |
| 11.5 | MECHANICAL DRAWING FOR THE STANDARD DIDSON 300M REAR FACING CONNECTOR | 22 |
| 11.6 | MECHANICAL DRAWING FOR THE DIDSON 1000M | 23 |
| 11.7 | MECHANICAL DRAWING OF DIDSON 3000M | 24 |
| 11.8 | SONAR CABLE – PIGTAIL PIN ASSIGNMENTS | 25 |

1 Introduction

This document will help you image with your DIDSON. It will explain how to put the components together, load the software, orient the sonar in the water for good imaging, and try out a few basic commands. Additional commands are found in the Software Manual placed on the Software CD. You also can use the online version by clicking the *Help* command on the DIDSON topside application, or click on the “?” button and then click on the command of interest.

2 What is a DIDSON?

DIDSON is an acoustic camera. It provides almost video-quality images in turbid or dark water where optical systems are ineffective. DIDSON uses acoustic lenses to focus beams and form an acoustic image on the transducer array. The lenses are housed in the rectangular housing and the electronics are housed in the cylindrical housing in the sonar. DIDSON forms images differently than an optical camera. DIDSON sends out short acoustic pulses in 48 or 96 acoustic beams. These beams are very narrow in the horizontal dimension (0.3° to 0.8°) and wide in the vertical dimension (14°). The beams are adjacent to each other and together form a field-of-view 29° horizontal and 14° vertical as shown in **Figure 1**. Objects within the field-of-view reflect sound back to the sonar. The sonar uses these echoes to form an image on the PC display.

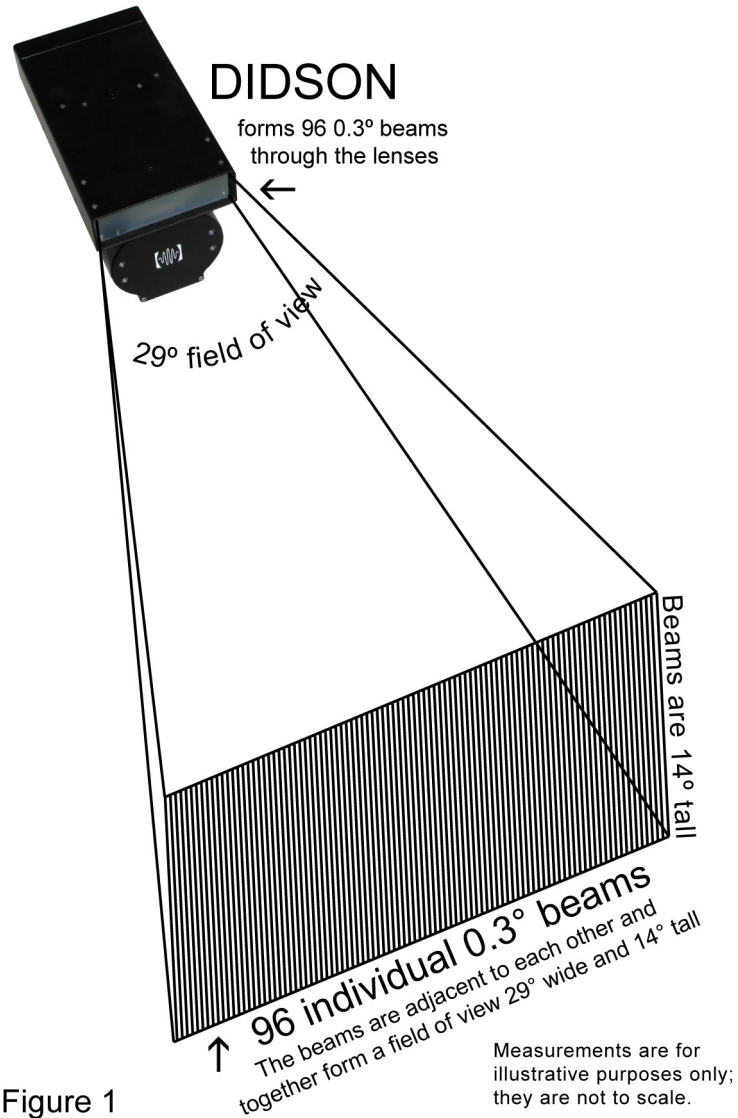
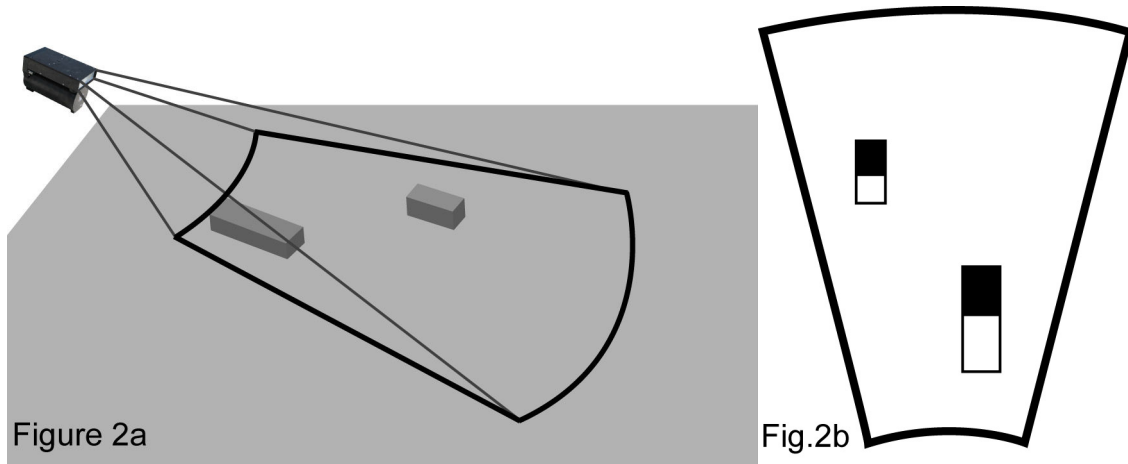

Figure 1

2.1 Aiming the DIDSON

DIDSON requires a different orientation to the imaged object than required by an optical camera. If you pointed the DIDSON perpendicular to the sea bottom, you would just get a bright line on the display drawn at a range marker on the display that corresponds to the distance the sonar is from the bottom. All of the transmitted pulses hit the bottom and bounce back at the same time. The sonar calculates the range using the time it takes each pulse to hit the bottom and bounce back to the sonar. To image objects on the bottom, the DIDSON should be near the bottom (1 – 2 meters above the bottom) and tilted down approximately 15° so the sound skims along the bottom and returns echoes that vary with intensity over time. **Figure 2a** shows a DIDSON ensonifying two targets on the bottom. **Figure 2b** shows the corresponding sonar display.



The targets appear to be seen from above. Each has an acoustic shadow (shown as a black rectangle in **Figure 2b**) where the sound blocked by the target does not strike the bottom. If the top of the target is rough and returns more sound than the sea bottom, the target will appear brighter than the image of the sea bottom. If the top of the target is very smooth, it may be darker than the image of the sea bottom. In **Figure 3a**, the sonar is too steep and the beam only skims a very small part of the bottom. This is a problem for two reasons. One, as seen in **Figure 3b**, it provides a very small area of surface examination and two, the sea bottom return is very bright at this steep angle and could easily mask returns from objects on the bottom. In other words, objects on the bottom are best seen when the grazing angle of the sound is small as shown in **Figure 2a**. The edges of the targets still return a lot of sound, but the bottom returns little sound. Thus the targets stand out.

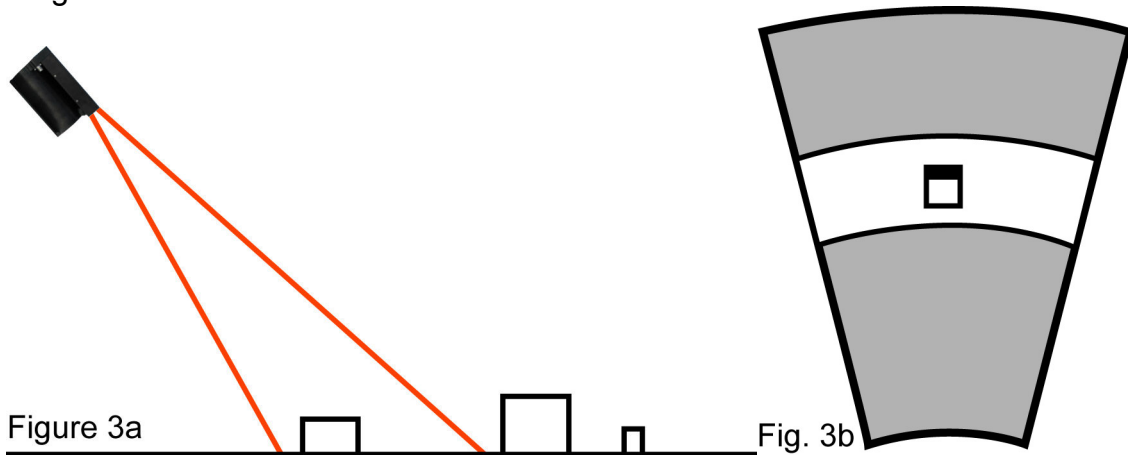

When objects (generally fish) are in the water column with some height from the bottom, they are easily imaged by the sonar. If the sonar points at the side of the fish, the image on the display appears as if the fish were seen from the top. If the sonar points at the top of the fish, the fish appear to be seen from the side.

2.2 Sonar movement affects image

The DIDSON can tolerate reasonable motion with little noticeable blurring of the image. However, rocking the sonar or panning it quickly while collecting data can blur the image. Also, objects moving quickly within the field-of-view will be blurred. In the high-frequency mode (HF), the DIDSON transmits 12 beams in parallel and builds up a 96-beam image in 8 transmit-receive cycles. The time it takes to build this image is the time it takes sound to make 8 roundtrips to the maximum range imaged. When imaging to a 10-m maximum range this total time is 0.1 second. When imaging to a 30-m maximum range it takes 0.15 seconds to build the image in LF mode. This is half the time it takes to build an image in HF mode for the same range. For maximum ranges greater than 15 meters, the standard unit switches to low-frequency (LF) mode and 48 beams make up the image. Only 4 transmit-receive cycles are needed to build an image in LF mode.

2.3 Mounting the DIDSON for optimum data collection

How you mount the DIDSON significantly affects the ease of collection and the quality of the collected data. The mounts vary with the location and type of work that needs to be done. Bottom mounts and ROV installations can be seen in the *Fisheries Management* and *Vehicle Vision* pages on the Sound Metrics web site.

2.4 Bottom mount

A bottom mount with a remote tilt capability is shown in **Figure 4**. Users “pan” the sonar by rotating the mount and remotely tilt the sonar by operation of the tilt motor on the mount to get the best image. A bottom mount can also be lowered from a boat and set on the bottom. In this case, the mount should have a pan/tilt device to remotely pan and tilt the sonar to aim at targets of interest.

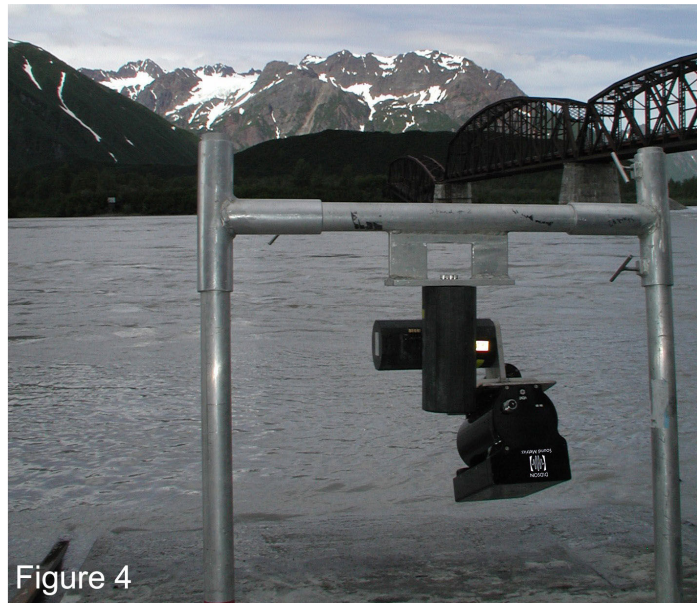

2.5 Pole mount

If the water is shallow and the surface is calm, one can use a pole mount off the side of the boat. The sonar needs to be lowered within a couple of meters off the bottom to image objects on the bottom. If DIDSON looks down at a steep angle, the returns from the bottom will be bright and mask the returns from the target (see Section 2.1). If the surface waves and swells rock and heave the boat, the sonar will move quite a bit and the image can be blurry (see Section 2.2). If the water is deep and/or the surface is not calm, it would be best to use an ROV or a mount that can be lowered to the bottom.

2.6 ROV mount

Remotely Operated Vehicles (ROVs) provide a great platform for a DIDSON. The mount should at least allow the sonar to tilt remotely. Turning the ROV can provide the pan. The ROV can be positioned to provide the optimum image, and hover while data are collected.

For complete gallery of all the mounts our users have shared with us, go to our web site www.soundmetrics.com and visit the Deploying DIDSON page.



3 Software Installation

Insert the Installation CD into the drive. It generally auto-starts and all you need to do is accept the default settings. If the installer does not start automatically, open the CD and double-click on *Setup.exe*.

- a) When given the choice between *Everyone* and *Just Me*, use the default *Everyone*. This allows automatic removal of old files when you update your DIDSON software.
- b) Allow the system to create the default data folder C:\DIDSON DATA
- c) Accept the defaults. When the program is installed, a program icon is automatically placed on the desktop.

4 Connecting the Components

4.1 Basic connection with sonar cable 500 feet or less (previously 200 feet or less)

In addition to your computer, here are the components for the basic connection with a sonar cable of 500 feet or less.

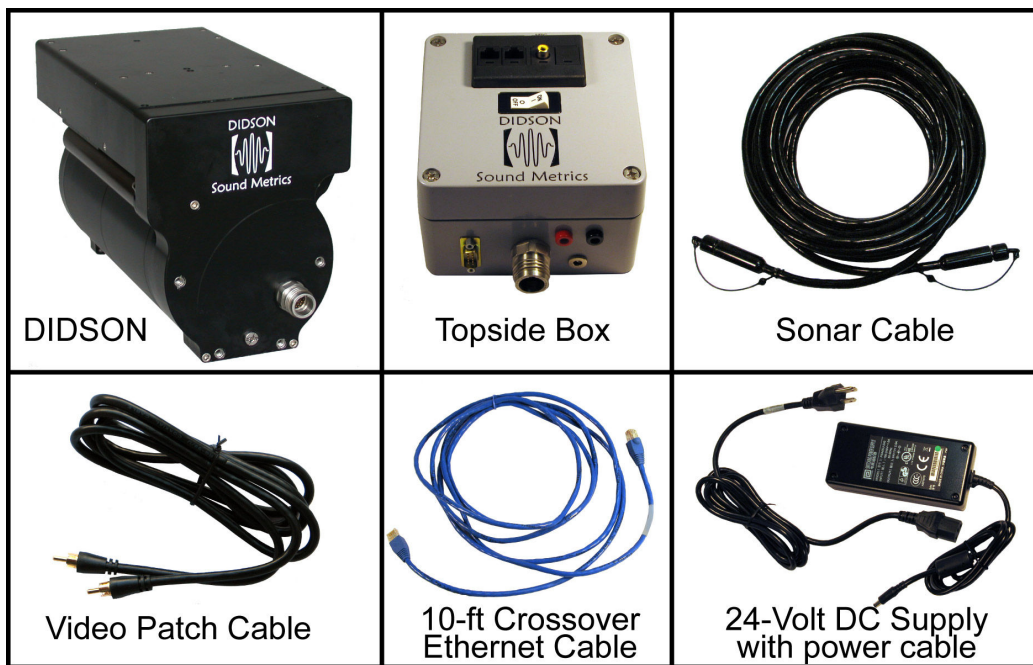

Figure 5a. Components for basic connection with sonar cable 500 feet or less

- Follow the steps below to configure the system with a sonar cable of 500 ft or less as shown in **Figure 5b**.
- Connect the black Sonar Cable between the DIDSON and the Topside Box.
- Connect the 10-ft Ethernet crossover cable between the Topside Box “PC” port and the computer Ethernet port.
- Make sure the Power Switch on the Topside Box is OFF.
- Connect the 24 VDC power supply to an AC power outlet and to the Topside Box power supply port.
- You can optionally connect the video cable between the NTSC Video output on the Topside Box and a video monitor if available.

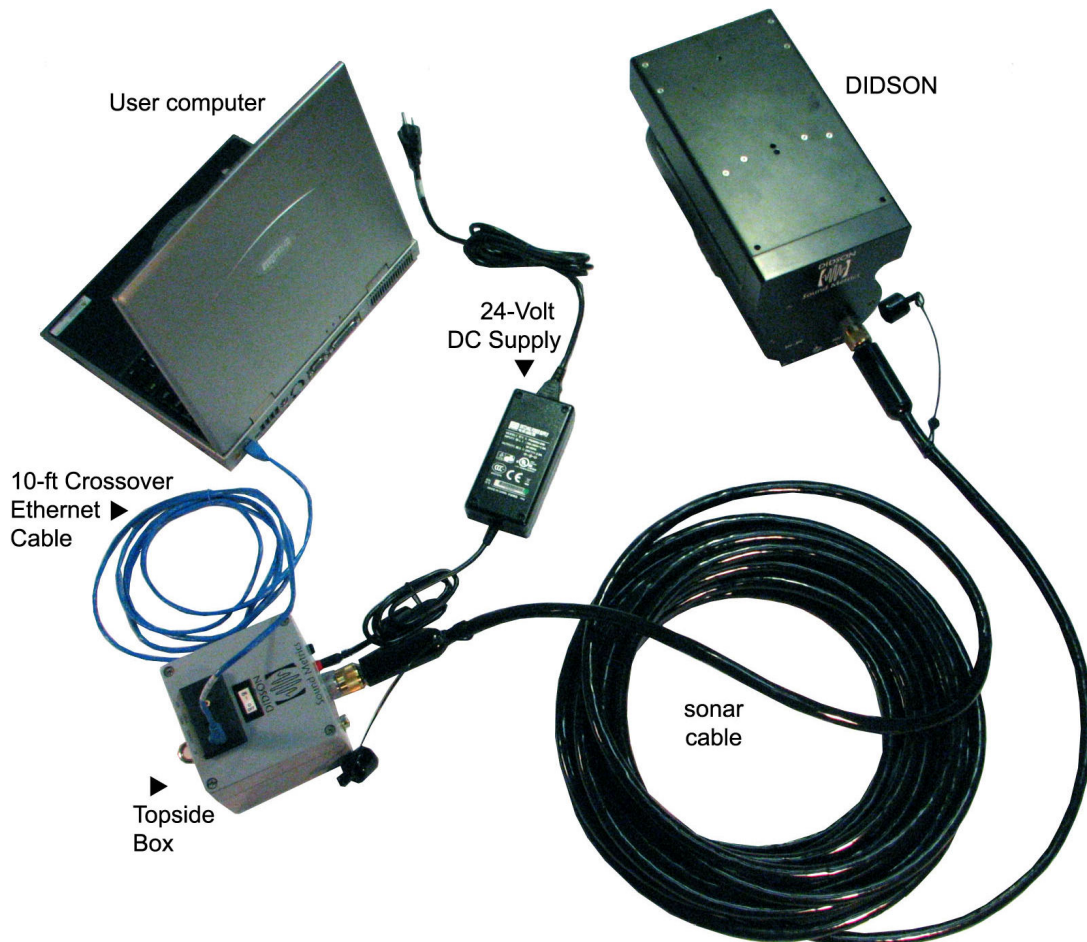
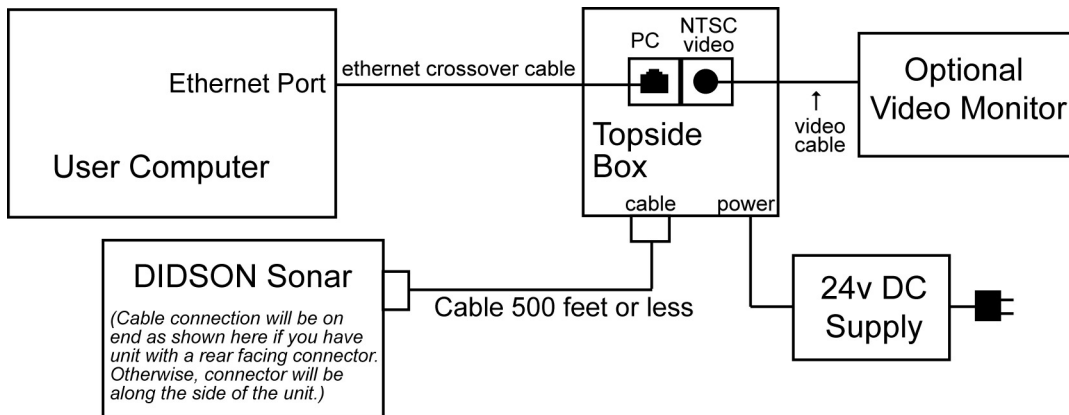

Figure 5b. Basic connection with sonar cable 500 feet or less

4.2 Basic connection with sonar cable greater than 500 feet (previously greater than 200 feet)

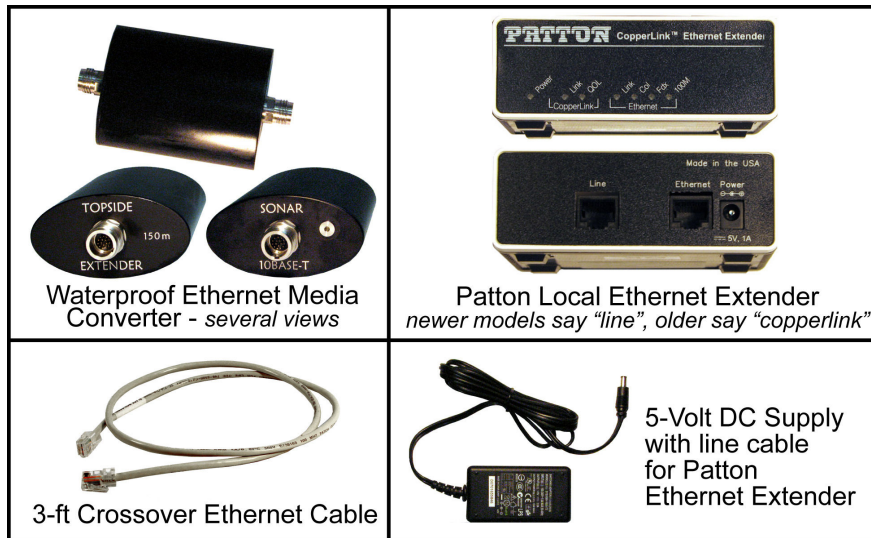

Figure 6a. Additional components required for sonar cable greater than 500 ft

- Follow the steps below to configure the system for a sonar cable greater than 500 ft as shown in **Figure 6b**.
- Connect the 50-ft (or shorter) sonar cable between the sonar and the connector labeled “Sonar” on the waterproof media converter housing.
- Connect the cable greater than 500 ft between the connector marked “Topside” on the waterproof media converter and the Topside Box.
- Connect the 10-ft crossover Ethernet cable between the 100/10baseT Ethernet port on the user computer and the Ethernet Port on the Local Patton CopperLink Ethernet Extender.
- Connect the 3-ft crossover Ethernet Cable between the “Line,” or in older units, the “CopperLink” port on the Local Patton Ethernet Extender and the “Copper” port on the Topside Box.
- Make sure the Power Switch on the Topside Box is OFF. Connect the 24 VDC power supply to an AC power outlet and to the Topside Box power supply port.
- Plug in the 5 VDC power supply between the Local Patton Ethernet Extender and an AC power outlet.
- You can optionally connect the video cable between the NTSC Video output on the Topside Box and a video monitor if available.
- **WARNING:** The waterproof media converter can overheat if left in air. For extended running, make sure it is in water – just a bucket of water will do.
- **IMPORTANT:** In the topside software, be sure the *Ethernet Transfer Mode* is set to *Packet Transfer*, or the Ethernet Extender will not communicate with the DIDSON. This is done by setting the following: *Sonar> Configure> Ethernet Transfer Mode> by Packet Request*. See **Figure 7**. For the highest possible frame rates, in software V5.16.04 and higher, choose: *Sonar>Configure>Ethernet Transfer Mode>by Packet Request>12 kb*.

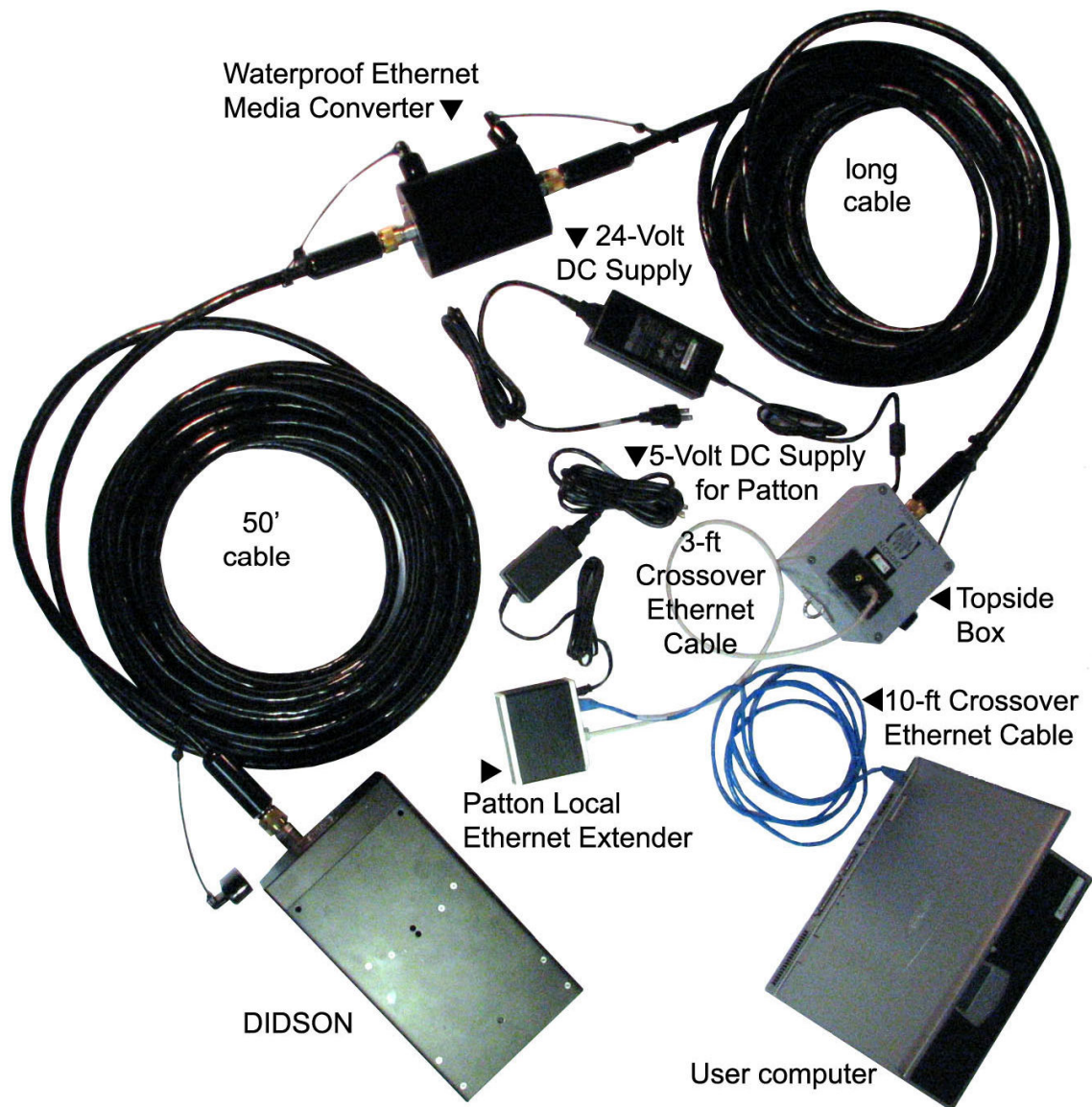
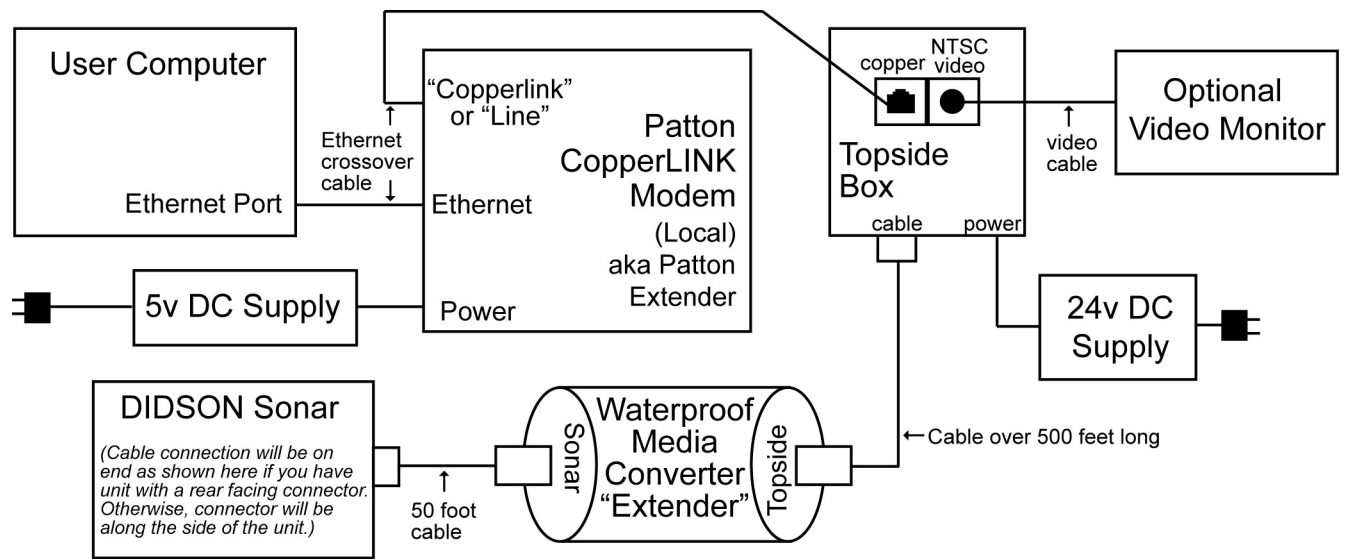

Figure 6b. Connections for cables 500 ft or longer

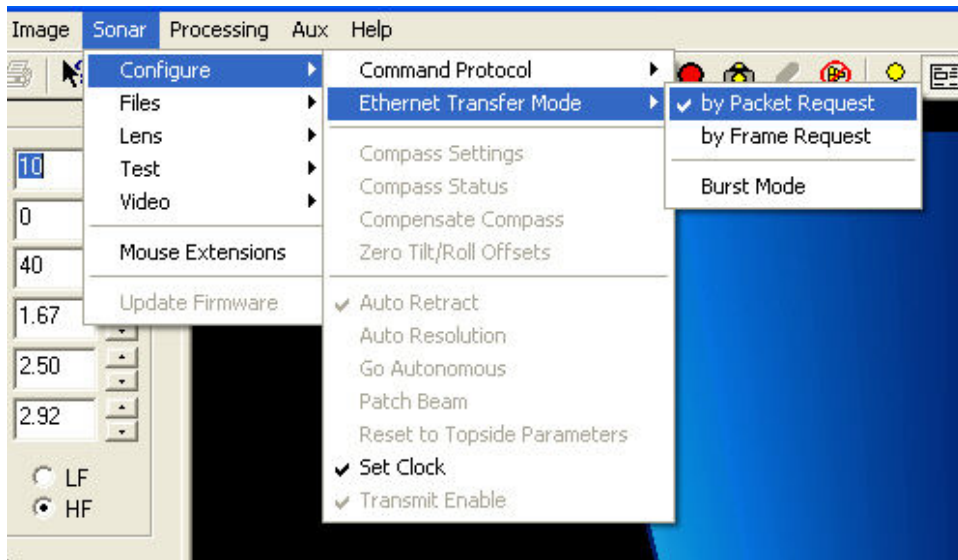

Figure 7. Select Ethernet Transfer Mode

5 Operation of the DIDSON

5.1 Turn on the sonar

Now that the software is installed and the components are connected, you are ready to turn on the DIDSON and confirm that all is working. Generally, it is OK to run the DIDSON out of the water for up to 30 minutes at room temperature (25°C). If you are going to need it on longer than that, put the sonar in a bucket or larger volume of water to dissipate the heat.

Turn the Topside Box power switch ON and click the topside DIDSON software icon to start up the software. When the software is up, make sure you are not in DEMO mode. Get out of DEMO mode by selecting the following on the upper menu bar (*Edit>Mode>(uncheck) Demo*). See **Figure 8**.

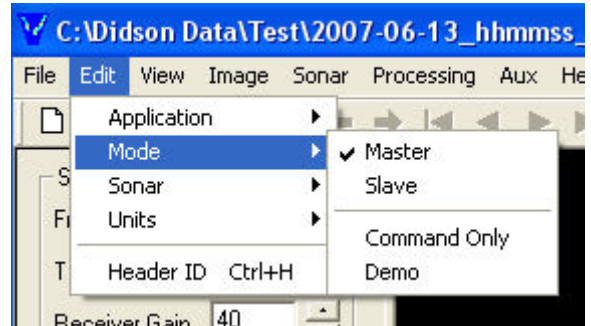
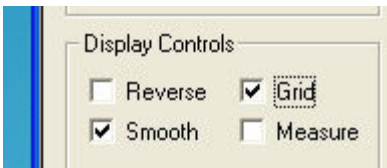

Figure 8

In the lower status bar, *DEMO MODE* will change to *NO SERVER* while it waits to connect to the sonar. If you have a video monitor connected, you will get visual feedback during the boot sequence. Without the monitor you still get some feedback. You generally hear the fan running inside the sonar (you may have to put your ear up to the housing), and after 35 seconds or so, you will hear the focus motor retract and then move forward to a previous focus selection. About one minute after power is supplied and the topside software activates, the DIDSON will connect to the PC and the displayed image will change to dark blue with some lighter speckles (assuming the sonar is still in air) and the *NO SERVER* message will change to *CONNECTED*. It will take a few seconds more for the sonar settings in the topside program to take full effect and the frame rate adjusts to the selected start window range and window length.

5.2 A few commands for operation



The display is a trapezoidal shape with the near range (bottom) and far range (top) sides forming arcs instead of lines. To better understand the display metrics, click on the grid selection in Display Controls as shown in **Figure 9**.

Figure 9

White range and bearing lines appear on the screen. The white arcs mark different ranges from the sonar. Numerical range markers tell you what the range is from the sonar to an object displayed on the screen. The diverging lines running in the vertical direction mark degrees off from center. The center mark at zero degrees marks objects directly in front of the sonar. Lines marked 4, 8, and 12, mark objects 4, 8, and 12, degrees off from center respectively. Sonars with an internal compass installed will display the (true or magnetic) heading output. You may want the gridlines off, but they are helpful when first learning the geometry of the display.

Make sure *Reverse* (also Display Controls) is correct for how you mount the sonar. If you mount the sonar so the rectangular lens compartment is up, *Reverse* is not checked. If you mount the sonar so the rectangular lens compartment is down, then check *Reverse*. This changes the left-right orientation of the display so the displayed left matches the physical left. This is done automatically when the mount orientation is selected with *Edit>Sonar>DidsonV5.ini File*.

To begin with, make sure that *Auto Freq* and *Auto Rate* are checked in Sonar Controls.

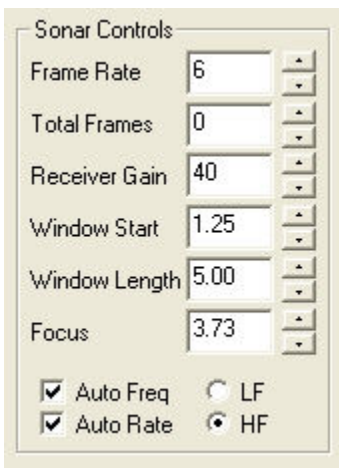

Click the up-arrow for *Window Start*. Note that the starting point (minimum range of the display) increases. Click the up-arrow of *Window Length* and the length of the window will double. You can also type in a number and press enter. The sonar will select a start range or window length as close as the hardware allows to the requested number. These two commands control the start and end ranges displayed. You may read the software manual documentation to learn about using your mouse on the display to make changes. For standard models, notice that when the maximum range exceeds 15 m, the sonar changes to 1.1 MHz (LF). When the maximum range is less than 15 m, the sonar changes the operating frequency to 1.8 MHz (HF). *Smooth* should be checked. That makes the image less blocky.

Figure 10

Threshold and Intensity (Display Controls) are used to bring out features on the display. Increasing *Threshold* darkens the low-level pixels – usually system noise that does not add to the image. Decreasing *Intensity* brightens the high-level pixels. To see their effect on the image, select *View>Palette* and change *Threshold* and *Intensity* settings. Think of the x-axis as being the entire range of possible echo values. If the echoes of interest fall within a narrow range, the *Intensity* and *Threshold* settings can stretch and contract the palette to match the range of interest.

Measure (Display Controls) allows one to measure distances between displayed objects. Check *Measure* and left-click the mouse at the first point of interest and drag the mouse to the second point of interest. A box is drawn with length, width and diagonal measurements written on the left bottom of the display. A single left-click will display range and bearing to a point within the image.

Record options: Recording can be as simple as toggling the red record button on the top toolbar. Other options include using a timer to turn on and off recording at different times each day (*Image>Capture>Timer Data Entry/Timer Recording*) and recording when motion is detected (*Image>Capture>Record Options>Periodic N Samps OverThreshold*). Use the “?” toolbar icon to find out more about any menu commands.



Replaying a file: Go to *File>Open* and select the file of interest. Use the forward, reverse, and single frame step commands to playback the file.

Figure 11

You can change the frame rate to play the file faster or slower than real-time. The recorded frame rate is listed by *Frame Rate* in the upper right side of the user interface.

Processing Toolbar. Select *View>Toolbars->Combined* to show additional processing options. Click on the “?”, then click on each of these buttons to get the description of what they do. Of special interest are *Background Subtraction*, *Transmission Loss Correction*, *Echogram* and *Motion Detection*.

There is much more to learn on your own. Click on the “?” in the top tool bar, then click on any command of interest for a description of that command. You can click on *Help* to display the built-in software manual. There is also a PDF file of this manual on the software CD.

5.3 Turn off the sonar

First, close the topside application. Wait 10 seconds while the focus motor automatically retracts its shaft. Then switch off the power on the Topside Box.

5.4 Useful Facts

- Topside Computer Screen Resolution Desired: minimum 1280x768 (1024x768 okay).
- Default Sonar IP Address: 128.95.97.227 Port 700
- If no AC line power is available, we suggest using a Deep Discharge 12V Battery and DC-AC inverter (200w will power the sonar and your laptop).

6 Maintenance

After each deployment, the DIDSON sonar should be thoroughly rinsed with fresh water. Submerging the unit in a bucket or small tank is best, especially if deployed in salt water, but rinsing with a hose is acceptable. For the DIDSON-DH model, this would include the battery housing and UHMD (mask display) as well.

Mud and silt can accumulate in the lens housing, connectors may get dirty, and a bubble eventually appears in the front lens. Here are instructions to rectify these issues.

6.1 Cleaning the lenses

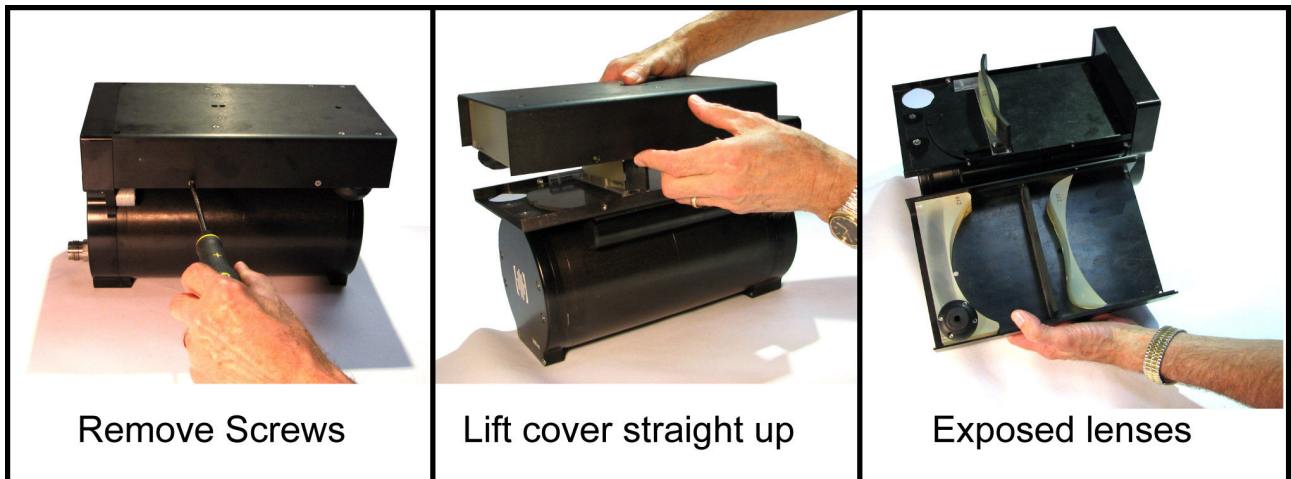

Figure 12. Accessing the lenses

Remove the four Philips screws (two on each side) securing the top of the lens housing. Remove the rectangular cover by lifting straight up. Wash the lens surfaces with water. Use a wet cloth or a narrow soft bristle brush. Don't brush or scrape the lenses with objects that scratch the plastic. *Older lenses: alcohol deteriorates the lens gasket. Do not tighten gasket to thickness less than 90% uncompressed thickness or gasket will be damaged.* Be sure to also clean the area around the array (the black rectangular face on the rear endcap.)

6.2 Cleaning the focus mechanism

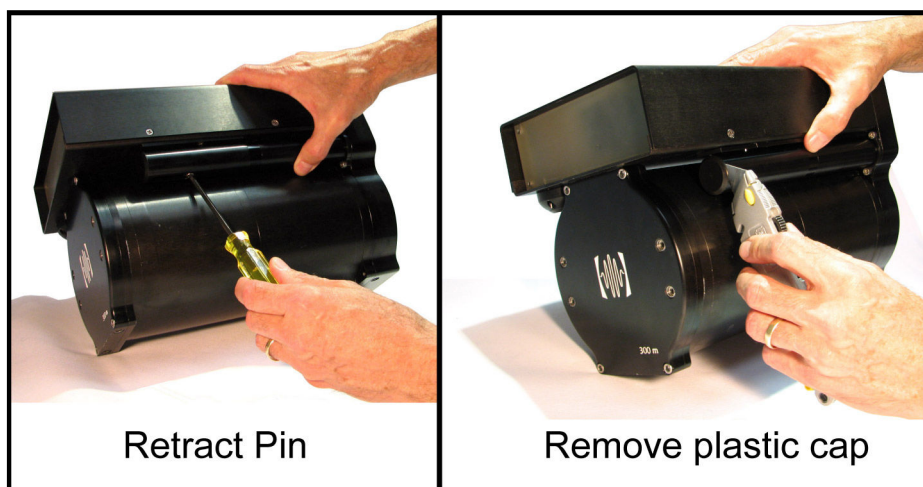

Figure 13. Retract focus pin from slider and if necessary remove cap from focus tube

Check to make sure that when you change focus the focus arm moves freely. The focus arm can bind if sand or other objects get lodged in the mechanism. Back out the focus arm pin inserted in the slider shown in Figure 12 (left). Slide the slider back and forth under running water and clean out debris until it slides smoothly. Remove the plastic cap in the front of the focus tube (Fig. 12 right). Wash out debris collected around the focus shaft that slides in and out of the focus tube. When the shaft is clear and the center lens slides easily, insert the focus pin back into the slider, snap on the front cap, and screw on the top housing. The system should be ready for many hours of imaging.

6.3 Remove the bubble in the front lens

The lens material is somewhat permeable to air. The bubble is generally due to a slow gain in air, not a loss in fluid. DIDSONs are shipped with a lens maintenance kit. The kit includes a white depressor, lens fluid, an applicator, and detailed instructions (also outlined below). If fluid is leaking out of the lens at the gasket or a crack in the plastic, the lens needs to return to the factory for repair or replacement.

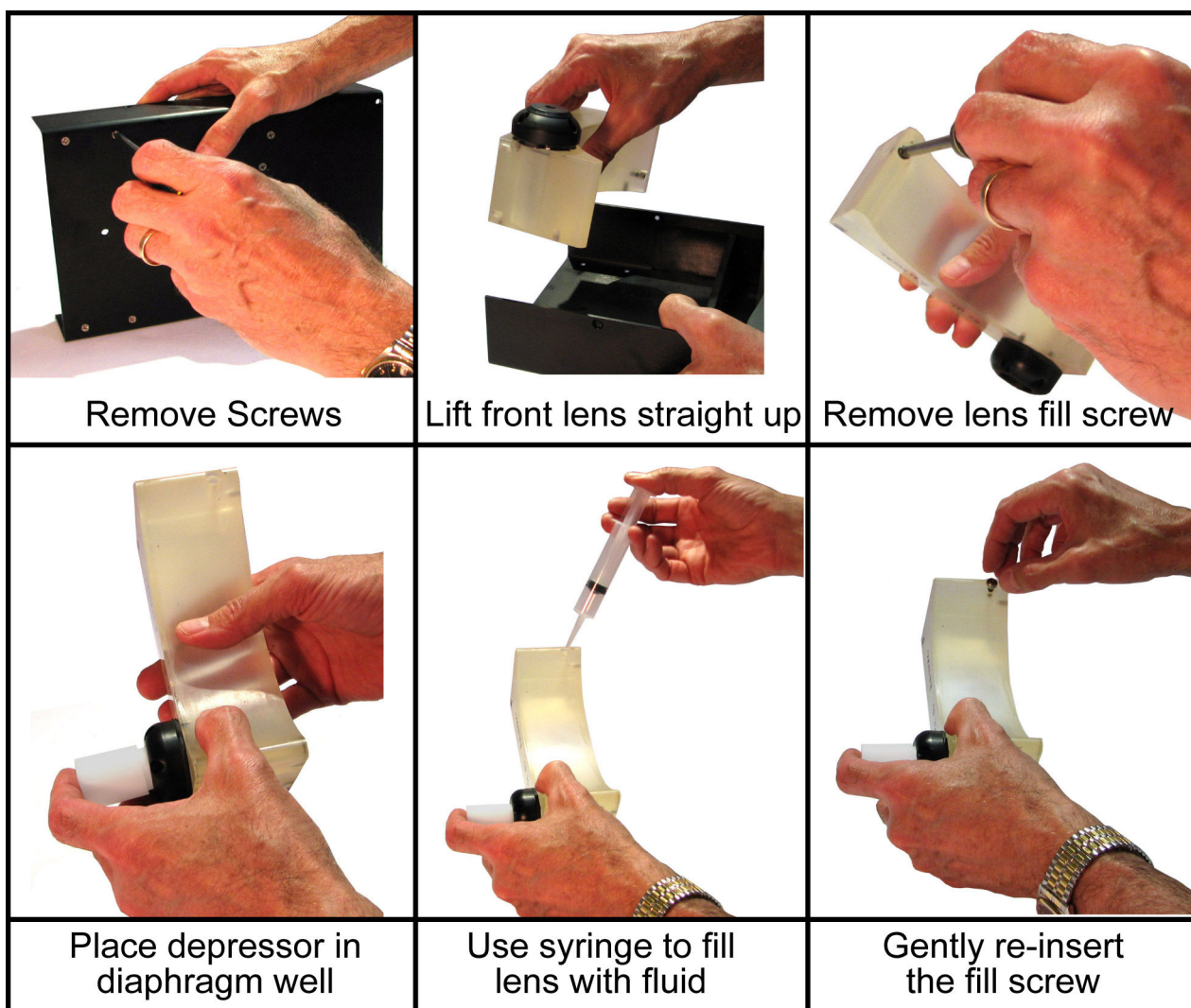

Figure 14. Removing air bubble from lens

If you wish to remove a bubble in your lens, do so **at room temperature**. Front lenses have a bellows or diaphragm that equalizes the pressure inside the fluid cavity. The bellows is in the black circular dome-like part. Some domes have a protective cap on top. Remove the cap by prying on its side with a sharp edge like a chisel or knife. Be careful not to puncture the bellows. Inside the dome you will see a rubber diaphragm.

There are two types of front lenses. The older ones have a small fill screw entering the side of the lens through a very thin wall of plastic. The newer lenses have a larger fill screw that has a piston o-ring and enters through a thicker part of the lens with substantial room for threads. This fill screw does not need to be tightly wrenched, the o-ring provides the necessary seal. **When removing and inserting the fill screw – especially in the older model – be very gentle to not strip the threads!**

Hold the lens with the fill screw at top. Remove the fill screw and gently place the white bellows depressor in the diaphragm well. After depressing the bellows, no air should remain in the lens. If some air remains, you can use lens fluid in the plastic bottle to fill the lens. Leave the depressor in place and use the syringe to place fluid in the fill hole. Gently re-insert the fill screw. Remove the depressor and there should no longer be a bubble in your lens.

IMPORTANT! *If you fill the lens with the bellows fully extended by not using the depressor, then there is no room for fluid expansion. This will either damage the lens or at least distort it to make the images blurry.*

6.4 Clean and lubricate the connectors

We recommend you use *3M Silicone Lubricant* to maintain the connectors on the sonar. It usually comes in a spray can for easy application to the sockets, pins, and o-ring. Remove dirt and other foreign material as needed.

6.5 Zinc Anodes

Each DIDSON sonar includes a sacrificial zinc anode to protect the housing from corrosion. The zinc is located facing forward on the rear endcap of the sonar's main pressure housing. It should be visually inspected every 6 months (more often if used in areas of abnormal corrosion) and replaced when significantly worn away.

7 Software/Firmware Upgrades

Sound Metrics maintains an FTP site with the latest software and firmware versions. Go to <ftp://ftp.soundmetrics.com> with username "software" and password "smcupdates". Read and follow the software installation instructions in the pdf files.

8 Troubleshooting

8.1 Software will not install

If you encounter problems installing or running the DIDSON topside software, you may not have all the necessary Windows XP system components loaded on your computer. Copy the file "WindowsInstaller-KB893803-v2-x86.exe" from the installation CD (or download it from <ftp://ftp.soundmetrics.com> with username "software" and password "smcupdates"). Double-click the file to install the latest Windows Installer components on your PC. Then try installing the DIDSON software application again (you may need to manually remove it first using *Start->Control Panel->Add/Remove Programs*). If you still encounter problems, contact Sound Metrics for further assistance.

8.2 Intermittent or no Ethernet connection to the sonar

8.2.1 Application set to DEMO mode

Make sure the *Edit->Mode->Demo* flag is NOT checked if you are connecting to the sonar. *Demo* mode is used to learn commands when no sonar is attached, or for image playback only. Make sure the *Edit->Mode->Master* flag IS checked. *Slave* mode is used for the remote viewing of DIDSON images on a multiple-PC network, but one and only one *Master* application is required to control the sonar.

8.2.2 Disable firewall.

If your computer has a software firewall enabled, you may need to disable it when connected to DIDSON, or else add DIDSON to the list of "allowed" applications.

8.2.3 Data rate set too high

When operating over cable lengths up to 200 feet, your Ethernet connection may be set to 100 or 10 Mbits/s. For cable lengths greater than 200 feet, you should set the link speed to 10 Mbit/s. Most NIC cards default to *Auto Negotiation*, which will normally be 100 Mbit/s (or 1 Gbit/s on some PCs). If your sonar has difficulty connecting, or the connection seems sporadic ("red squares" flashing in the image display window even at low frame rates) then try forcing your Ethernet connection to 10 Mbits/s. To force the connection to 10 Mbit/s, navigate to the *Local Area Connection Properties* Window by the following steps: *Start >My Network Places >View Network Connections >Local Area Connection*. Select the *General* tab and then click on the *Configure* button. Click on the *Advanced* tab and then find the *Link Speed* or similarly named property. Select either 10 Mbit/s Full or 10 Mbit/s Half mode, then click OK until all windows are closed.

8.2.4 Patton Ethernet Extenders

The Extenders require packet transfer. To set this mode, click on the following: *Sonar >Configure >Ethernet Transfer Mode >by Packet Transfer*. In software V5.16.04 and higher, choose: *Sonar>Configure>Ethernet Transfer Mode>by Packet Request>12 kb* for the highest possible frame rates.

9 Optimizing/Customizing sonar parameters

The sonar's *Didson.ini* file is configured at the factory for your sonar. There are a number of options best left in default mode, but if you need to change one of the settings below, use the command *Edit>Sonar>DidsonV5.ini File* while connected to the sonar.

a) *Configuration*: The S/N (serial number) should match the number on the sonar rear endcap. If your sonar is a Long Range sonar, check *Long Range*. If you have a 1000m or 3000m depth-rated sonar, check the *1000m/3000m* box. If you change values in the *Configuration* area, you will need to check the *Enable Update* box.

b) *Network settings*: Unless you specified a different sonar IP address, the sonar has the default address of: 128.95.97.227. The *Subnet Mask* should be 255.255.255.0. The *Gateway* is unused but must have numbers entered.

c) *Mount Orientation*: Checking this makes sure that Left-Right orientation is displayed properly. If the sonar is mounted in the water with lens compartment at top, check *Top*. Orientation can also be changed with *Reverse* display control on the user interface.

d) *Temp & Salinity values*: If the temperature and salinity values are correct for your environment, then focus will be optimized at the center range of the display. These corrections provide minor changes. In general, brackish and 10-20 C give good results independent of your environment, but focus may be fine-tuned for greater accuracy.

10 Contact Information

Manufactured by **Sound Metrics Corporation**

15029 Bothell Way NE, Suite 100

Lake Forest Park, WA 98155

(206) 364 - 1441 Office

(206) 374 - 2929 FAX

support@soundmetrics.com

www.soundmetrics.com

Sales by **Ocean Marine Industries Inc.**

2810 Hudson Street

Chesapeake, VA 23324

(757) 382 - 7616 Voice

(757) 382 - 5012 FAX

info@oceanmarineinc.com

www.oceanmarineinc.com

11 SPECS and MECHANICAL DRAWINGS

All Specs and Drawings are also available on the Products pages of our website.

11.1 Specifications - Standard DIDSON models

Detection Mode

| | |
|---|--------------------------------------|
| Operating Frequency | 1.1 MHz |
| Beamwidth (two-way) | 0.5° H by 14° V |
| Number of beams | 48 |
| Extended Range settings | |
| window start | 0.83 m to 25.8 m in 0.83 m intervals |
| window length | 5 m, 10 m, 20 m, 40 m |
| range bin size relative to window length: | 10 mm, 20 mm, 40 mm, 80 mm |
| pulse length relative to window length: | 18 μs, 36 μs, 72 μs, 144 μs |

Identification Mode

| | |
|---|-----------------------------------|
| Operating Frequency | 1.8 MHz |
| Beamwidth (two-way) | 0.3° H by 14 ° V |
| Number of beams | 96 |
| Extended Range settings | |
| start range | 0.42m to 12.92 in 0.42m intervals |
| window length | 1.25 m, 2. 5 m, 5 m, 10 m |
| range bin size relative to window length: | 2.5 mm 5 mm, 10 mm, 20 mm |
| pulse length relative to window length: | 4.5 μs, 9 μs, 18 μs, 36 μs |

Both Modes

| | |
|--|--|
| Max frame rate (window length dependent) | 4-21 frames/s |
| Field-of-view | 29° |
| Remote Focus | 1 m to max range |
| Power Consumption | 30 Watts typical |
| Control | Ethernet |
| Display Up-link | Ethernet or NTSC Video |
| Maximum cable length (100/10BaseT) | 152 m (500 feet) |
| Maximum cable length (Patton Extender) | 1220 m (4000 feet) (with local power) |
| Maximum cable length (fiber optics) | kilometers |
| Topside Requirements: | Windows (XP, VISTA), Ethernet card, Video monitor (optional) |

11.2 Specifications - Long Range DIDSON models

Detection Mode (LF)

| | |
|---------------------|-----------------|
| Operating Frequency | 0.700 MHz |
| Beamwidth (two-way) | 0.8° H by 14° V |
| Number of beams | 48 |

Extended Range settings

| | |
|---|--------------------------------------|
| window start | 0.83 m to 25.5 m in 0.83 m intervals |
| window length | 10 m, 20 m, 40 m, 80 m |
| range bin size relative to window length: | 19 mm, 39 mm, 78 mm, 156 mm |
| pulse length relative to window length: | 23 μs, 46 μs, 92 μs, 184 μs |

Identification Mode (HF)

| | |
|---|---------------------------------|
| Operating Frequency | 1.2 MHz |
| Beamwidth (two-way) | 0.5° H by 14 ° V |
| Number of beams | 48 |
| Extended Range settings | |
| window start | 0.42 to 12.92 in 0.42 intervals |
| window length | 2.5 m, 5 m, 10 m, 20 m |
| Range bin size relative to window length: | 4.9 mm, 9.8 mm, 19.5 mm, 39 mm |
| Pulse Length relative to window length: | 6.7 μs, 13 μs, 26 μs, 54 μs |

Both Modes

| | |
|--|--|
| Max frame rate (window length dependent) | 2-10 frames/s |
| Field-of-view | 29° |
| Remote Focus | 1 m to max range |
| Power Consumption | 30 Watts typical |
| Control | Ethernet |
| Display Up-link | Ethernet or NTSC Video |
| Maximum cable length (100/10BaseT) | 152 m (500 feet) |
| Maximum cable length (Patton Extender) | 1220 m (4000 feet) (with local power) |
| Maximum cable length (fiber optics) | kilometers |
| Topside Requirements: | Windows (XP, VISTA), Ethernet card, Video monitor (optional) |

11.3 WEIGHT and DIMENSIONS SUMMARY for each model

| | | |
|-----------------|-----------------|--------------------------------|
| Weight in Air | 300 meter unit | 7.9 kg (17.4 lb.) |
| | 1000 meter unit | 10.6 kg (23.2 lb.) |
| | 3000 meter unit | 13.9 kg (30.5 lb.) |
| Weight in Water | 300 meter unit | 1.0 kg neg. (2.2 lb.) |
| | 1000 meter unit | 2.7 kg neg (6.0 lb.) |
| | 3000 meter unit | 6.1 kg neg. (13.4 lb.) |
| Dimensions | 300 meter unit | 31.0 cm by 20.6 cm by 17.1 cm |
| | 1000 meter unit | 32.5 cm by 18.36 cm by 22.4 cm |
| | 3000 meter unit | 32.5 cm by 18.36 cm by 22.4 cm |
| Depth rating | 300 meter unit | 300 meters (1000 feet) |
| | 1000 meter unit | 1000 meters (3300 feet) |
| | 3000 meter unit | 3000 meters (10,000 feet) |

11.4 Mechanical Drawing for the Standard DIDSON 300m Forward Facing Connector

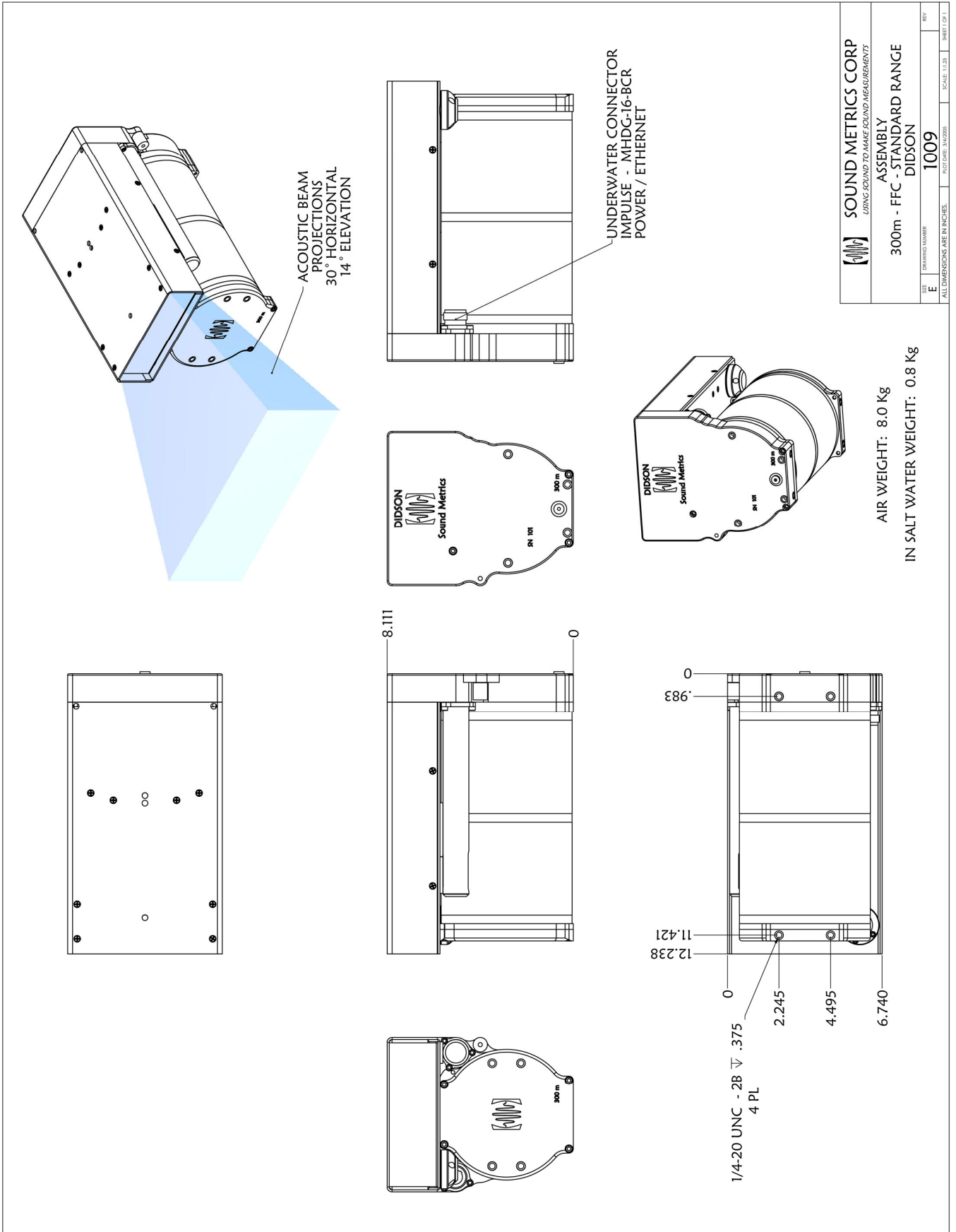

11.5 Mechanical Drawing for the Standard DIDSON 300m Rear Facing Connector

ACOUSTIC BEAM PROJECTIONS
30° HORIZONTAL
14° ELEVATION

UNDERWATER CONNECTOR
IMPULSE - MHDG-16-BCR
POWER / ETHERNET

AIR WEIGHT: 8.0 Kg
IN SALT WATER WEIGHT: 0.8 Kg

| | |
|--|------------------------------------|
| SOUND METRICS CORP <small>USING SOUND TO MAKE SOUND MEASUREMENTS</small> | |
| ASSEMBLY 300m - RFC - STANDARD | |
| DIDSON | |
| 1003 | <small>SCALE: 1:1</small> |
| <small>DATE</small> E | <small>REV</small> 1 |
| <small>DRAWING NUMBER</small> E | <small>PLOT DATE: 03/09/06</small> |
| <small>ALL DIMENSIONS ARE IN INCHES.</small> | |
| <small>SCALE: 1:1</small> | <small>SHEET 08 OF 1</small> |

11.6 Mechanical Drawing for the DIDSON 1000m

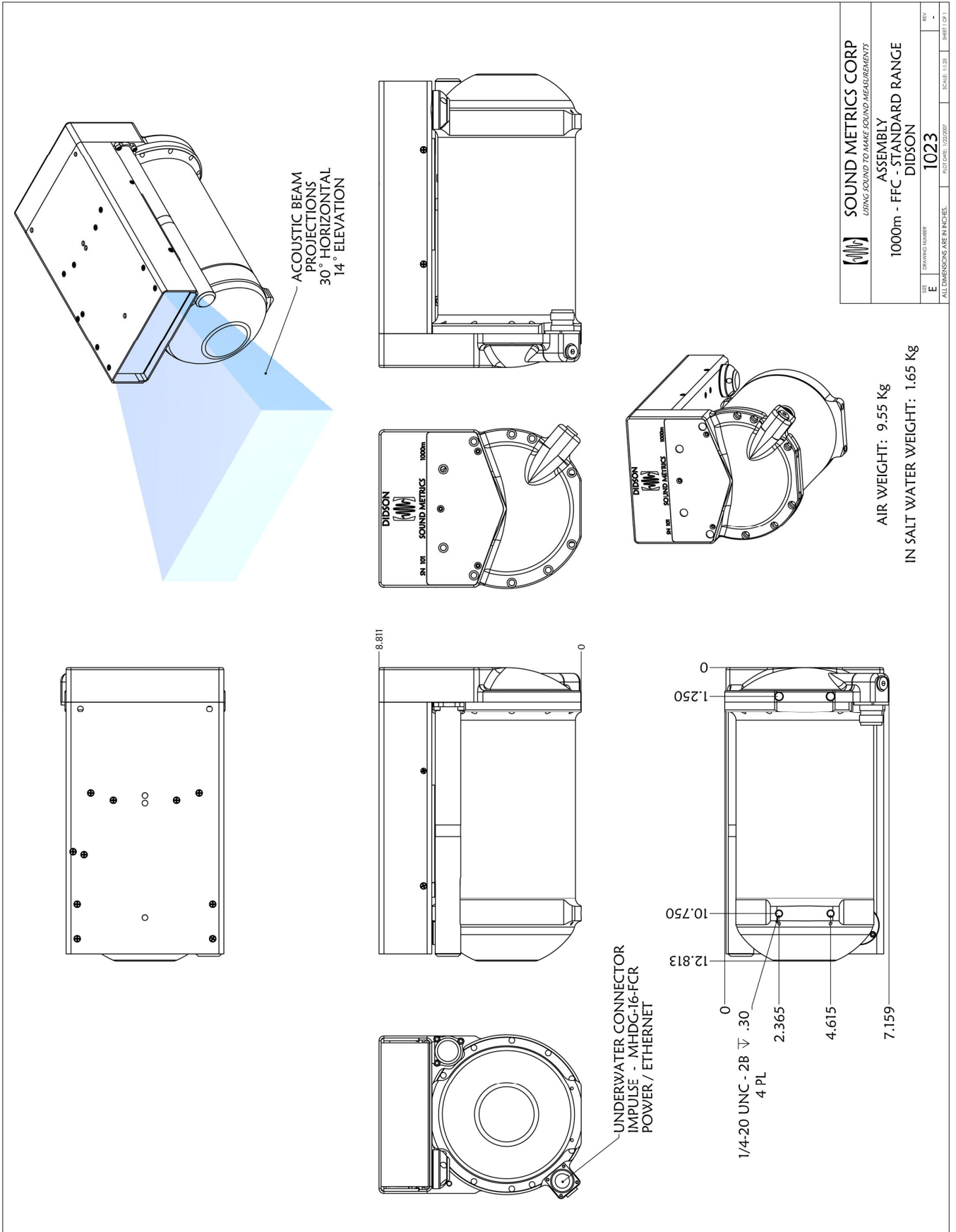

11.7 Mechanical Drawing of DIDSON 3000m

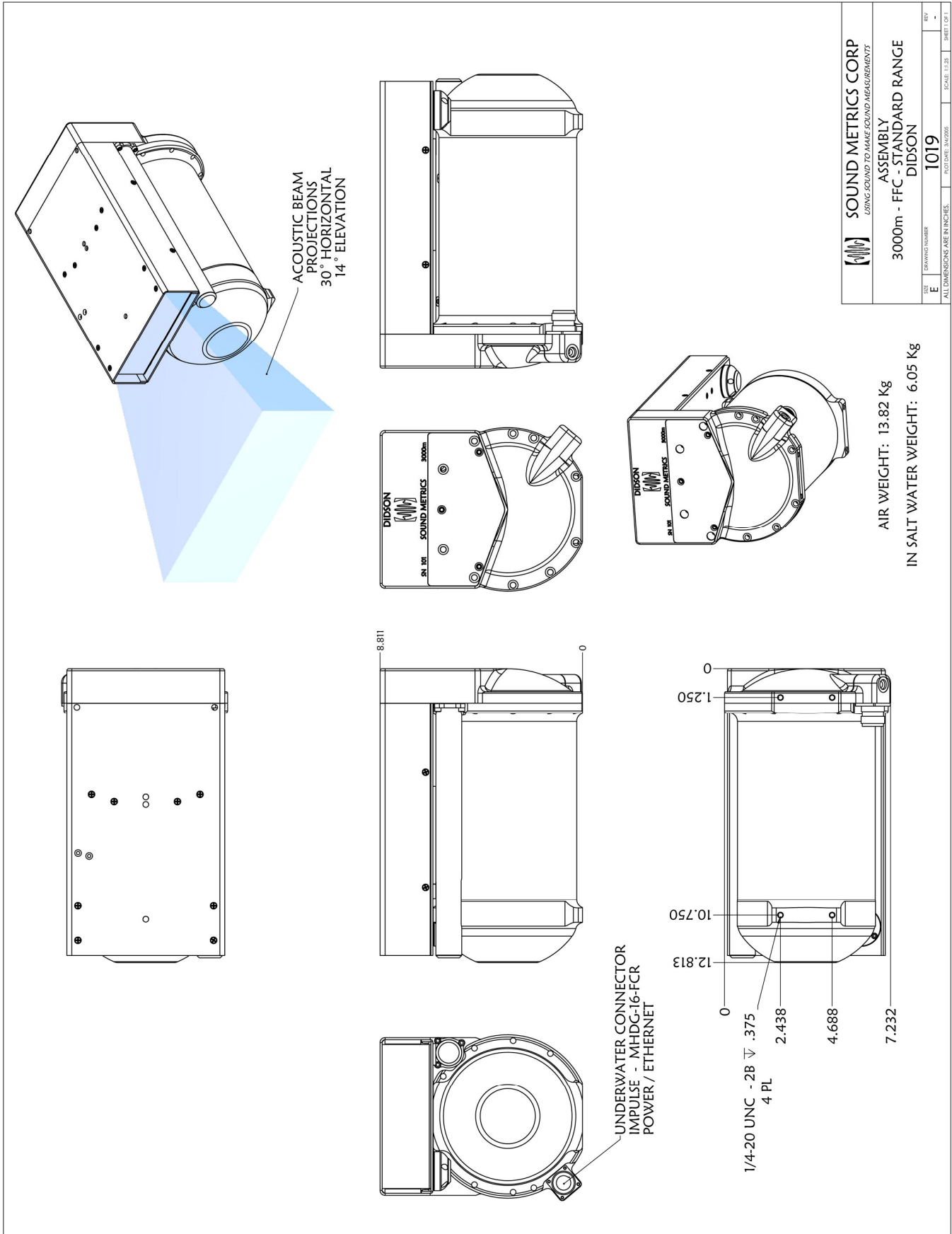

11.8 Sonar Cable – Pigtail Pin Assignments

DIDSON Sonar Cable - AC010FPIG-SPD-23449
Pigtail (or whip)

MHDG-16-CCP connector on 10-foot cable

| Pin | Wire Color | Function |
|-------|-----------------|---|
| 1 | 14awg-Red | DC V+ |
| 2 | 14awg-Black | DC V- |
| 3 | | NC |
| 4 | TP-white/Green | NTSC Output (Center Coax) |
| 5 | TP-Green | NTSC Ground (Shield Coax) |
| 6 | TP-White/Brown | NC |
| 7 | TP-Brown | NC |
| 8 | TP-White/Blue | 10/100BaseT Ethernet Tx+ (Tx data from sonar) |
| 9 | TP-Blue | 10/100BaseT Ethernet Tx- |
| 10 | TP-White/Orange | 10/100BaseT Ethernet Rx+ (Rx data to sonar) |
| 11 | TP-Orange | 10/100BaseT Ethernet Rx- |
| 12-15 | | NC |
| 16 | | TP-shield drain wire |

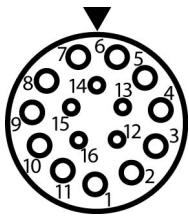

MHDG-16-CCP
Cable Face View

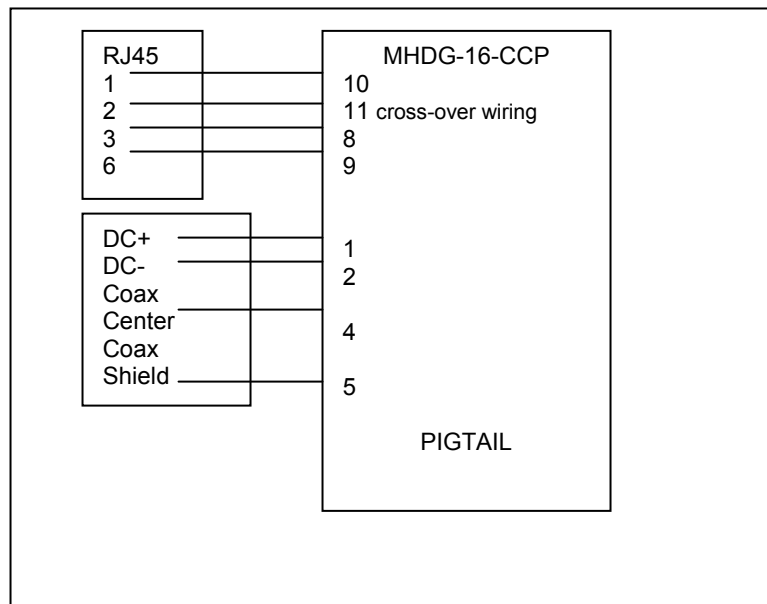

Wiring for crossover Ethernet appropriate for peer to peer connections including Patton Ethernet Extenders. Sometime direct Ethernet wiring is appropriate (possible if a hub or switch is involved).