

LONG RANGER & QUARTERMASTER OPERATION MANUAL



P/N 957-6269-00 (April 2019)

© 2019 Teledyne RD Instruments, Inc. All rights reserved.

Information included herein is controlled by the Export Administration Regulations (EAR) and may require an export license, license exception or other approval from the appropriate U.S. Government agency before being exported from the United States or provided to any foreign person. Diversion contrary to U.S. law is prohibited.

TABLE OF CONTENTS

CHAPTER 1 - AT A GLANCE	1
System Overview	2
Long Ranger / QuarterMaster Models and Options	6
Computer Considerations	7
Power Overview.....	7
Power on Cycle.....	7
AC Power Adapter	7
Internal Battery Power Overview.....	8
Setting up the System	11
Initial Battery Connection.....	11
Set Up the Long Ranger / QuarterMaster ADCP	12
Connecting to the System using TRDI Toolz.....	13
Connecting to the System using BBTalk.....	14
Changing the Baud Rate in the ADCPs	16
Caring for your System.....	17
General Handling Guidelines	17
Assembly Guidelines	18
Deployment Guidelines.....	18
CHAPTER 2 - INSTALLATION	19
Using the Cable Clips	20
I/O Cable and Dummy Plug.....	20
Connecting the External Battery Case	22
Routing Cables.....	24
Cable Wiring Diagrams	25
Mounting the Instrument.....	28
Bottom Mounts	28
Buoy Mounts and Load Cages	29
Fixed Mount.....	30
Fixed Mount Periodic Maintenance	31
CHAPTER 3 – DATA COLLECTION	33
Collecting Self-Contained Data	34
Recover Data with WinSC	44
Viewing Data with <i>WinSC</i>	45
Collecting Real-Time Data.....	46
Sending the Commands to the ADCP	51
Sending the Commands using TRDI Toolz.....	51
Sending the Commands using BBTalk.....	51
Viewing Data in Real-Time	53
CHAPTER 4 - MAINTENANCE	55
Parts Location Drawings	56
Maintenance Schedule	60
Calibration Items.....	60
Maintenance Items	60
Spare Parts	62
Disassembly and Assembly Procedures	63
Removing the End-Cap.....	64
Removing the Battery Pack Modules.....	65
Removing the Housing Assembly	66
O-ring Inspection and Replacement	66
High Pressure O-rings	67
Replacing the Housing Assembly.....	68
Installing the Battery Pack Modules.....	70

Replacing the End-Cap	71
Periodic Maintenance Items	73
Replacing the Battery Cores	73
Using Lithium Battery Packs	74
Testing the Lithium Battery Pack	75
Replacing the External Battery Case Cores	76
Calibrating the Compass	77
Compass Background	77
Preparing for Calibration	77
Compass Calibration Verification	79
Compass Calibration	80
Single-Tilt Compass Calibration Procedure	82
Replacing the Desiccant Bags	85
Cleaning the Pressure Sensor Port	86
Purge Plug Inspection & Replacement	87
Protective Coating Inspection and Repair	89
Zinc Anode Inspection and Replacement	90
Zinc Anode Inspection	90
Zinc Anode Electrical Continuity Check	90
Zinc Anode Replacement	91
Preventing Biofouling	93
Antifouling Paints	94
Applying Antifouling Paints	94
Removing Biofouling	95
Installing Firmware Upgrades	96
Installing Feature Upgrades	96
Maintenance Procedures	98
Replacing the PC Card Recorder	98
Replacing Fuses	99
Changing Communications Setting	100
Installing the Spare Boards Kit	100
Removing the Original Set of Boards	101
Installing the Spare Board Kit	102
Installing the Beam Cosine Matrix	104
Testing the System after Replacing Boards	104
Long Ranger / QuarterMaster Conversions	105
Converting from Self-Contained to Direct-Reading	105
Converting from Direct-Reading to Self-Contained	105
Converting a SC Housing to an External Battery Case	106
Replacing the End Cap Connector	107
Equipment Provided	107
Customer Supplied Additional Equipment	107
Removing the End-Cap Connector	108
Installing the New End-Cap Connector	109
Wiring Diagram	112
Replacing the CPU Lithium Battery	113
Testing the CPU Lithium Battery Voltage	113
Replacing the CPU Lithium Battery	114
CHAPTER 5 – TESTING THE ADCP	115
Testing the ADCP with <i>WinSC</i>	116
Testing the ADCP with <i>TRDI Toolz</i>	117
Test Results	118
Deploy Commands List	118
System Commands List	119
Time Set	119
Recorder Free Space	119
Display System Parameters	120

Instrument Transformation Matrix	120
Pre-deployment Test	121
Testing the Sensors	122
Beam Continuity.....	122
CHAPTER 6 - TROUBLESHOOTING	123
Equipment Required	124
Basic Steps in Troubleshooting.....	125
Troubleshooting the ADCP	125
Troubleshooting Safety.....	125
Troubleshooting a Communication Failure	126
Incorrect Wakeup Message	126
No Wakeup Message.....	127
Check the Power.....	127
Check the I/O Cable	128
ADCP Checks	128
Troubleshooting a Built-In Test Failure.....	129
When to use the Spare Boards Kit.....	130
Troubleshooting a Beam Failure.....	132
Troubleshooting a Sensor Failure.....	133
Fault Log.....	133
System Overview	134
Operating Modes.....	134
Command Mode	134
Ping Mode	134
Overview of Normal ADCP Operation	135
Functional Description of Operation	135
Input Power.....	135
Board Descriptions.....	136
Sensors	137
CHAPTER 7 - RETURNING SYSTEMS TO TRDI FOR SERVICE	141
Shipping the ADCP.....	141
Returning Systems to the TRDI Factory.....	142
Returning Systems to TRDI Europe Factory	143
CHAPTER 8 - SPECIFICATIONS	147
Outline Installation Drawings.....	154
APPENDIX A - NOTICE OF COMPLIANCE.....	176
Date of Manufacture.....	177
Environmental Friendly Use Period (EFUP).....	177
WEEE.....	177
Material Disclosure Table	178

LIST OF FIGURES

Figure 1.	Standard Long Ranger / QuarterMaster Overview.....	3
Figure 2.	High-Pressure Long Ranger Overview.....	4
Figure 3.	High-Pressure QuarterMaster Overview – (6000 meter Direct Reading Shown).....	5
Figure 4.	AC Power Adapter	8
Figure 5.	Battery Modules.....	10
Figure 6.	Initial Battery Connection.....	11
Figure 7.	Long Ranger / QuarterMaster Connections	12
Figure 8.	Removing the I/O Cable.....	21
Figure 9.	External Battery Case Connection.....	22

Figure 10.	External Battery Pack Connection using a WorkHorse External Battery.....	22
Figure 11.	Do not use Zip-Ties Directly on Cables.....	24
Figure 12.	Cables Protected with Abrasion Resistant Sleeving.....	25
Figure 13.	Long Ranger / QuarterMaster I/O Cable Wiring.....	26
Figure 14.	Extension Cable.....	26
Figure 15.	WorkHorse External Battery Pack “T” Cable.....	27
Figure 16.	RS232-to-RS422 Converter Wiring (25-Pin to 9-Pin).....	27
Figure 17.	Trawl Resistant Bottom Mount.....	28
Figure 18.	Long Ranger / QuarterMaster being Deployed.....	29
Figure 19.	Deep-Water Mount.....	29
Figure 20.	Buoy Mount with External Battery.....	29
Figure 21.	Subsurface Buoy.....	30
Figure 22.	Buoy Mount.....	30
Figure 23.	Direct-Reading Configuration.....	30
Figure 24.	Fixed Mount Clamp Design.....	31
Figure 25.	Barnacle Damage to Urethane Face.....	31
Figure 26.	Long Ranger / QuarterMaster Housing Removal.....	56
Figure 27.	Long Ranger / QuarterMaster Part Locations.....	57
Figure 28.	Long Ranger / QuarterMaster Battery Modules.....	58
Figure 29.	External Battery Case.....	59
Figure 30.	Transducer View.....	61
Figure 31.	End-Cap View.....	61
Figure 32.	High Pressure O-Ring Detail View.....	68
Figure 33.	Housing Mounting Hardware.....	69
Figure 34.	Installing the Battery Modules.....	70
Figure 35.	End-Cap Mounting Hardware.....	72
Figure 36.	Battery Pack Modules.....	74
Figure 37.	Workhorse Lithium Battery Pack.....	75
Figure 38.	Rotating the Long Ranger / QuarterMaster Shipping Case During Compass Calibration.....	81
Figure 39.	Compass Calibration.....	83
Figure 40.	Self-Contained Long Ranger / QuarterMaster Tilted Position in Shipping Case.....	84
Figure 41.	Direct-Reading Long Ranger / QuarterMaster Tilted Position in Shipping Case.....	84
Figure 42.	Long Ranger / QuarterMaster Pressure Sensor.....	87
Figure 43.	Purge Plug O-Ring Replacement.....	88
Figure 44.	1500 meter Housing Flange Anodes.....	92
Figure 45.	End-Cap Anodes.....	92
Figure 46.	Transducer Anode.....	93
Figure 47.	Installing Feature Upgrades.....	97
Figure 48.	PC Card Recorder Access Slot.....	98
Figure 49.	Fuse.....	99
Figure 50.	Communication Setting Switch.....	100
Figure 51.	Installing the Spare Boards Kit.....	103
Figure 52.	Long Ranger / QuarterMaster Configurations.....	105
Figure 53.	Modified Dummy Plug.....	108
Figure 54.	Extracting Wrench.....	108
Figure 55.	Lock Nut Removal Socket.....	108
Figure 56.	Removing the Connector.....	109
Figure 57.	End-Cap Connector with Isolation Bushing.....	110
Figure 58.	Long Ranger / QuarterMaster End-Cap Assembly.....	111
Figure 59.	End-Cap Connector Wiring – Long Ranger / QuarterMaster ADCP.....	112
Figure 60.	Lithium Battery Test Points on the CPU Board.....	114
Figure 61.	Lithium Battery.....	114
Figure 62.	Using WinSC to Test an ADCP.....	116
Figure 63.	Using TRDI Toolz to Test an ADCP.....	117
Figure 64.	Long Ranger / QuarterMaster Wake-up and Timer Logic.....	138
Figure 65.	Long Ranger / QuarterMaster DC Power Path.....	139
Figure 66.	Long Ranger / QuarterMaster Block Diagram.....	140

Figure 67.	967-1082.....	155
Figure 68.	967-6021 (Sheet 1 of 2)	156
Figure 69.	967-6021 (Sheet 2 of 2)	157
Figure 70.	967-6051, External Battery Case	158
Figure 71.	967-6055 (Sheet 1 of 4)	159
Figure 72.	967-6055 (Sheet 2 of 4)	160
Figure 73.	967-6055 (Sheet 3 of 4)	161
Figure 74.	967-6055 (Sheet 4 of 4)	162
Figure 75.	967-6082, Sheet 1	163
Figure 76.	967-6082, Sheet 2	164
Figure 77.	967-6082, Sheet 3	165
Figure 78.	967-6082, Sheet 4	166
Figure 79.	967-6083, Sheet 1	167
Figure 80.	967-6083, Sheet 2	168
Figure 81.	967-6083, Sheet 3	169
Figure 82.	967-6083, Sheet 4	170
Figure 83.	967-6083, Sheet 5	171
Figure 84.	967-1106, Sheet 1	172
Figure 85.	967-1106, Sheet 2	173
Figure 86.	967-6085, External Battery Case, 3000 Meters, Sheet 1.....	174
Figure 87.	967-6085, External Battery Case, 3000 Meters, Sheet 2.....	175

LIST OF TABLES

Table 1:	Long Ranger / QuarterMaster Spare Parts	62
Table 2.	Replacement Kits.....	63
Table 3:	List of Least Replaceable Assemblies.....	124
Table 4:	Required Test Equipment	124
Table 5:	Pre-deployment Test (PA) Possible Cause of Failures.....	131
Table 6:	Water Velocity Profiles.....	148
Table 7:	Echo Intensity Specifications.....	149
Table 8:	Measurement Performance - Long Ranger 75 kHz	149
Table 9.	Measurement Performance – QuarterMaster 150 kHz	150
Table 10:	Data Communication Specifications.....	151
Table 11:	Transducer and Hardware Specifications.....	151
Table 12:	Power Specifications	152
Table 13.	Lithium Battery Specifications.....	152
Table 14:	Standard Sensors.....	153
Table 15:	Environmental Specifications.....	153
Table 16:	Outline Installation Drawings.....	154
Table 17.	Toxic or Hazardous Substances and Elements Contained in Product.....	178

CONVENTIONS USED IN THIS MANUAL

Conventions used in the Long Ranger / QuarterMaster Acoustic Doppler Current Profiler (ADCP) Operation Manual have been established to help learn how to use the system quickly and easily.

Menu items are printed in bold: click **Collect Data**. Items that need to be typed by the user or keys to press will be shown as **<F1>**. If a key combination were joined with a plus sign (**<ALT+F>**), press and hold the first key while pressing the second key. Words printed in italics include program names (*TRDI Toolz*) and file names (*TestWH.rds*).

Code or sample files are printed using a fixed font. Here is an example:

```
[BREAK Wakeup A]
WorkHorse Broadband ADCP Version 50.40
Teledyne RD Instruments (c) 1996-2012
All Rights Reserved.
>
```

You will find three other visual aids that help you: Notes, Cautions, and References.



This paragraph format indicates additional information that may help you avoid problems or that should be considered in using the described features.



This paragraph format warns the reader of hazardous procedures (for example, activities that may cause loss of data or damage to the Long Ranger / QuarterMaster ADCP).



This paragraph format tells the reader where they may find additional information.



Weight in air for a LongRanger/QuarterMaster system is between 38.5 Kg (85 pounds) to 124.7 Kg (275 pounds). Use lifting aids and proper lifting techniques when moving.

HOW TO CONTACT TELEDYNE RD INSTRUMENTS

If you have technical issues or questions involving a specific application or deployment with your instrument, contact our Field Service group:

Teledyne RD Instruments	Teledyne RD Instruments Europe
14020 Stowe Drive Poway, California 92064	2A Les Nertieres 5 Avenue Hector Pintus 06610 La Gaude, France
Phone +1 (858) 842-2600	Phone +33(0) 492-110-930
FAX +1 (858) 842-2822	FAX +33(0) 492-110-931
Sales – rdisales@teledyne.com	Sales – rdie@teledyne.com
Field Service – rdifs@teledyne.com	Field Service – rdiefs@teledyne.com

Client Services Administration – rdicsadmin@teledyne.com

Web: <http://www.teledynemarine.com/rdi>

For all your customer service needs including our emergency 24/7 technical support, call +1 (858) 842-2700

Self-Service Customer Portal

Use our online customer portal at <http://www.teledynemarine.com/rdi> and click on the **Support** link to download manuals or other Teledyne RDI documentation.

Teledyne Technologies Secure Extranet

Teledyne RD Instruments Firmware, software, and Field Service Bulletins can be accessed only via our Customer Support Portal.

To register, please go to <https://extranet.teledyne.com/layouts/15/Registration/registration.aspx?company=7> to set up your customer support account. After your account is approved, you will receive an e-mail with a link to set up your log in credentials to access the portal (this can take up to 24 hours).

Once you have secured an account, use <https://extranet.teledyne.com/sites/Marine/RDI> to access this data with your unique user name and password.

If you have an urgent need, please call our Technical Support hotline at +1-858-842-2700.

REVISION HISTORY

April 2019

- Updated outline installation drawing 967-6083
- Added outline installation drawing 967-1106
- Updated logo to Teledyne Marine.

September 2018

- Added vent plug use and lifting caution to System Overview.
- Added using the cable clips to the I/O Cable and Dummy Plug section.
- Added the Lithium Battery Pack information from FST-053.
- Added the purge plug and vent plug to the maintenance chapter.
- Updated the O-Ring Detail View.
- Corrected the Installing the Spare Board Kit torque specification for the M4 screws holding the PC board stack to the transducer head from 4 Nm to 6 Pound-Force Inch (0.67 Nm).
- Updated the Testing the CPU Lithium Battery Voltage section.
- Updated the overview drawings to show vent plug location.
- Updated the outline installation drawings.

February 2013

- Initial release: Replaces the following manuals:
 - Long Ranger Technical Manual P/N957-6120-00
 - QuarterMaster Operation Manual P/N957-6213-00
 - Long Ranger User's Guide P/N957-6129-00
 - QuarterMaster User's Guide P/N957-6214-00

EXCLUSIONS AND OMISSIONS

1: None

Chapter 1

AT A GLANCE



In this chapter, you will learn:

- System Overview
- Long Ranger & QuarterMaster Models and Options
- Computer Considerations
- Power Overview
- Setting up the Long Ranger/QuarterMaster ADCP
- Caring for your System

System Overview

The Long Ranger and QuarterMaster systems consists of a ADCP, cables, battery pack, flash memory card, and software. Both battery capacity and memory can be increased with upgrades for longer deployments. Use the *PlanADCP* software to confirm you have enough memory and battery capacity for your deployment. The ADCP can also be used for direct-reading current profile operation. They only require the addition of a Windows® compatible computer to configure the ADCP and to replay collected data. See the [Outline Installation Drawings](#) for dimensions and weights.

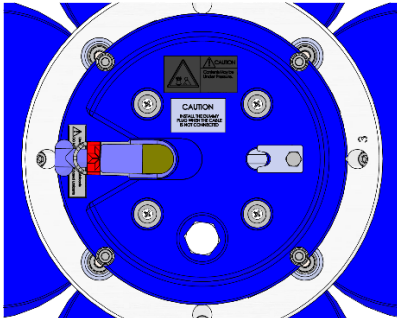
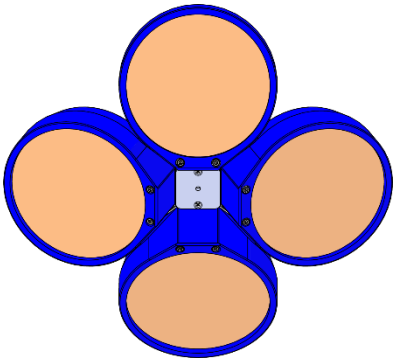
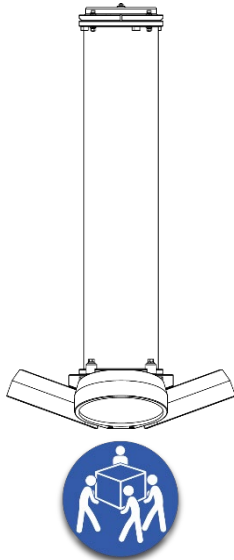
Picture	Description
	<p>The Input/Output (I/O) cable connects the ADCP to the computer and external power supply. When the cable is not connected, use the dummy plug to protect the connector.</p> <p>The Beam-3 mark shows the location of Beam-3 (Forward).</p> <p>The end-cap holds the I/O cable connector. When assembling the unit, match the Beam 3 mark on the end-cap with beam 3 number on the transducer.</p> <p>Use the Vent Plug to vent the system before opening the housing. Loosen the port ½ turn and listen for airflow; if none, then open another ½ turn and listen again for airflow. Repeat until the Vent Plug is fully removed. This will ensure no internal pressure is present when removing the housing.</p>
	<p>The transducer assembly contains the transducer ceramics and electronics. The standard acoustic frequency is 75 kHz for Long Ranger ADCPs and 150 kHz for the QuarterMaster. The orange urethane faces covers the transducer ceramics. Never set the transducer on a hard surface. The urethane faces may be damaged.</p> <p>The Thermistor is embedded in the transducer head and measures the water temperature.</p> <p>The pressure sensor (standard 200 Bar) measures water pressure (depth) and is located under the square anode.</p>
	<p>The standard ADCP housing allows deployment depths to 1500 meters. The housing is available in 851.0mm (Self-Contained and optional External Battery Case), 608.0mm (2 battery pack Self-Contained), and 330.2mm (Direct Reading) lengths.</p> <p>The ADCP electronics and transducer ceramics are mounted to the transducer head. The numbers embossed on the edge of the transducer indicate the beam number. When assembling the unit, match the transducer beam number 3 with the Beam 3 mark on the end-cap.</p> <p>The Self-Contained ADCP includes a longer housing to hold up to four alkaline battery packs. The internal battery pack has 450 watt-hours (Wh) of usable energy at 0 C. When fresh, the voltage is +42 VDC. When depleted, the voltage drops to 30 VDC or less.</p> <p>Long Ranger / QuarterMaster ADCPs come standard with one memory card. Two PCMCIA memory cards slots are available. The maximum memory for each slot is 2GB, with the total memory capacity not to exceed 4GB.</p> <p>Weight in air for a LongRanger/QuarterMaster system is between 38.5 Kg (85 pounds) to 124.7 Kg (275 pounds). Use lifting aids and proper lifting techniques when moving.</p>

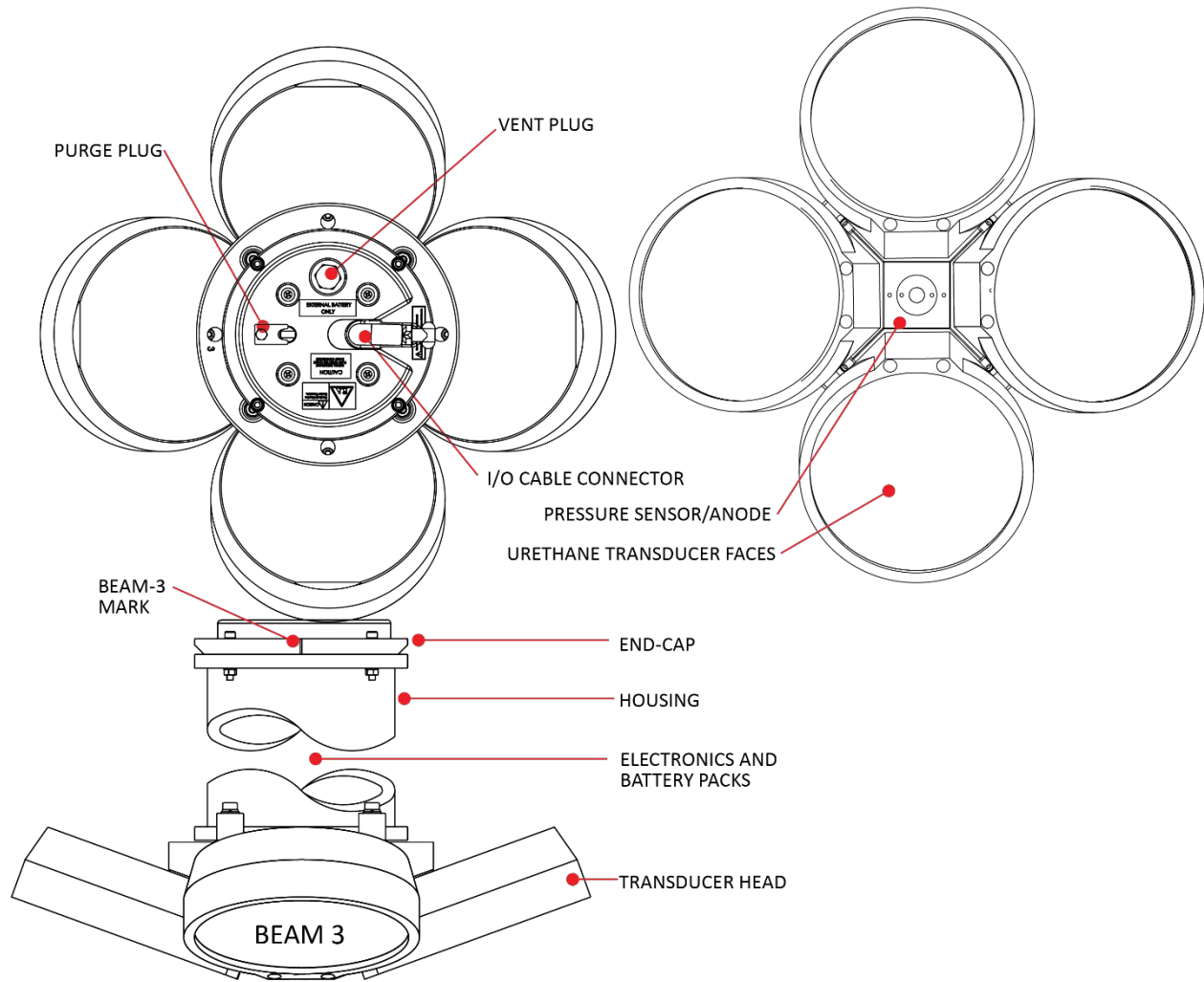

Figure 1. Standard LongRanger / QuarterMaster Overview

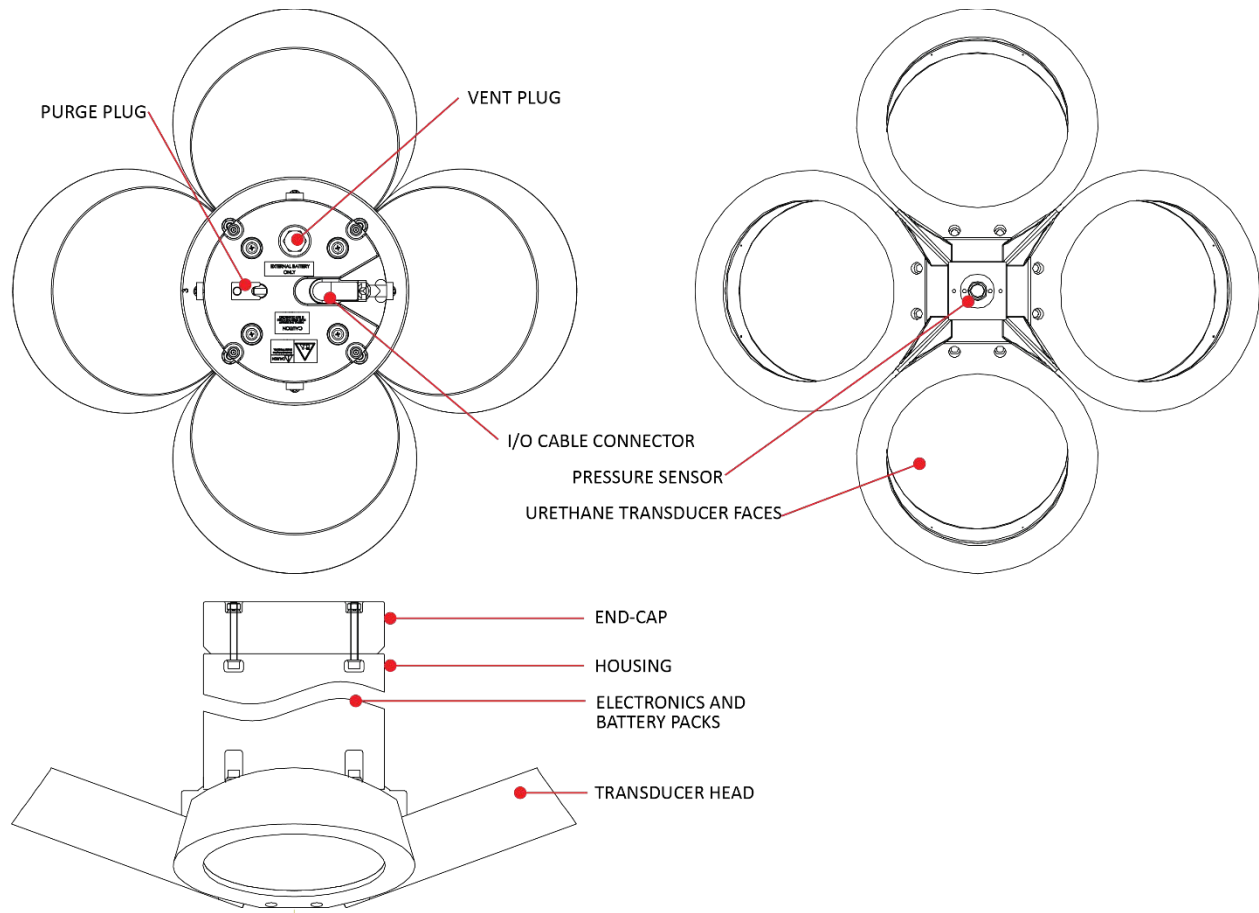

Figure 2. High-Pressure Long Ranger Overview

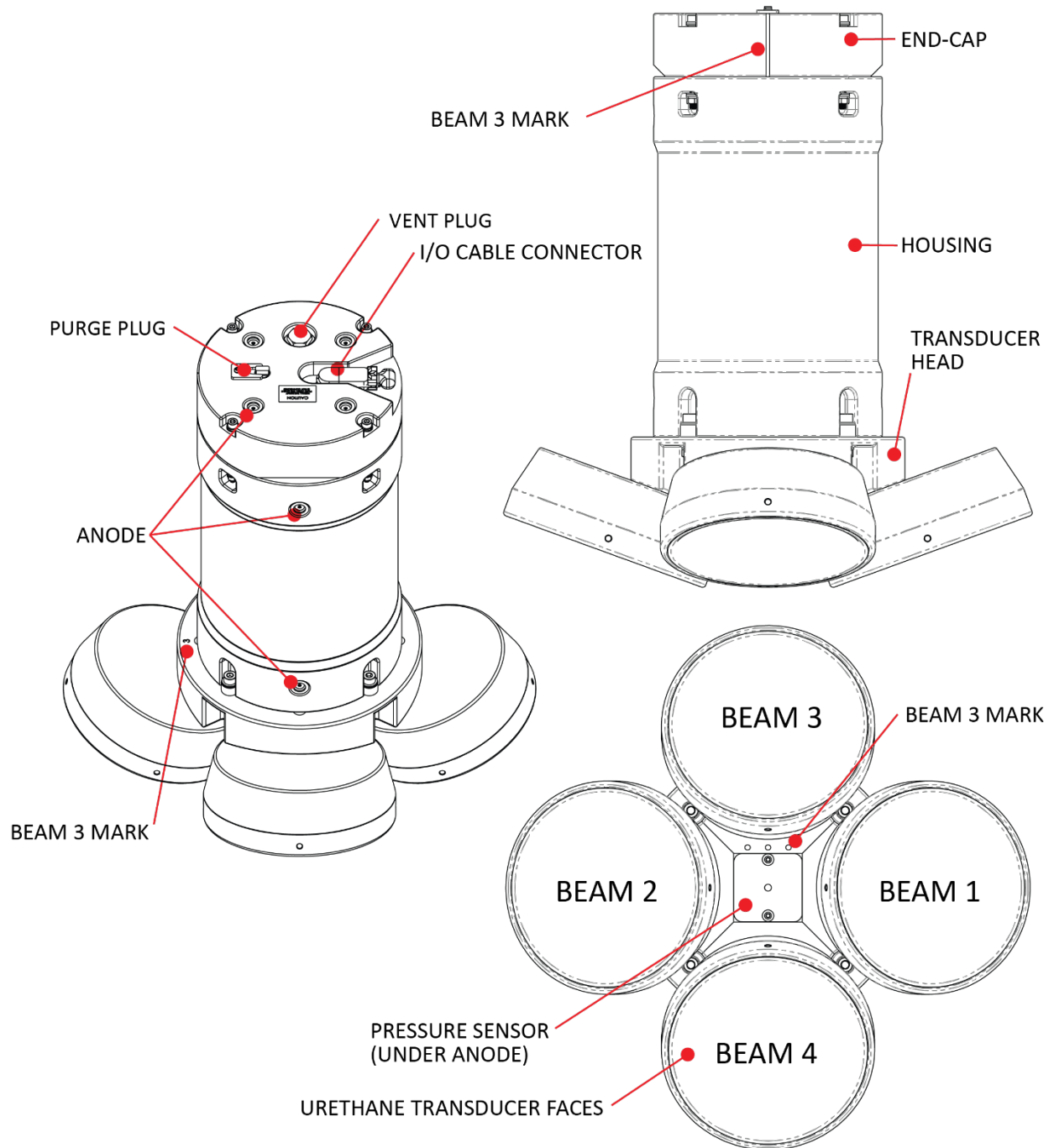

Figure 3. High-Pressure QuarterMaster Overview – (6000 meter Direct Reading Shown)

Long Ranger / QuarterMaster Models and Options

The following section explains the different options available for the Long Ranger / QuarterMaster.

- **Direct Reading Upgrade** – The Direct Reading Long Ranger / QuarterMaster is for real time data collection from a stationary platform (for example, from an oil platform or from the bottom looking up and wired to shore).
The Direct Reading Long Ranger / QuarterMaster with External Battery Case is designed to allow for mounting the transducer closer to the bottom or inside of a surface buoy with the batteries in a separate waterproof case.
- **External Battery Case** – Adding external batteries is typically used to increase the deployment for Long Ranger / QuarterMasters. The External Battery can be used to provide backup power for real-time deployments.
- **Memory** – The Long Ranger / QuarterMaster includes one memory card. Two PCMCIA memory card slots are available (see [PC Card Recorder](#) for memory card specifications). The maximum memory for each slot is 2GB, with the total memory capacity not to exceed 4GB.
- **High-Pressure Systems** – The standard Long Ranger / QuarterMaster system allows deployment depths to 1500 meters. High-pressure systems are available in depth rating of 3000 meters and 6000 meters (QuarterMaster only). This option is not available as an upgrade as it requires a special transducer assembly and housing. See the outline installation drawings for dimensions and weights (see [Dimensions](#)).
- **High Power Extended Range (QuarterMaster 6000m depth version only)** – Increases transmit power by a factor of 2.25. The higher power output maintains high performance and the maximum possible range performance in deep, low backscatter waters.
- **Spare boards kit** – Contains a set of spare printed circuit boards for a quick replacement in the event of a failure. The kit contains a calibrated set and the boards should not be separated. The set does not include the receiver or tuner boards (not field replaceable).
- **LADCP/Surface Track/WM15** – With the Water Mode 15 feature upgrade installed, the Long Ranger / QuarterMaster has the capability to be set up as a Lowered ADCP (LADCP). The LADCP uses one or two Workhorse ADCPs mounted on a rosette. The rosette is lowered through the water column (one ADCP is looking up and the other is looking down). This setup allows you to cover a larger part of the water column. By lowering the ADCPs through the water column you can get an ocean profile that is greater in range than the systems combined. In a setup like this, you would want the ADCPs to collect data at the same time or synchronize their pinging when using two ADCPs. Please refer to the [LADCP User's Guide.pdf](#) (item 10a on TRDI's website) for more details.
- **VmDas Software** – Controls the Long Ranger / QuarterMaster and displays profile data through a personal computer (provided with the Direct Reading upgrade).

Computer Considerations

TRDI designed the ADCP to use a Windows® compatible computer. The computer controls the ADCP and displays its data, usually through our *WinSC*, *WinADCP*, or *VmDas* programs.



TRDI highly recommends that you download and install all of the critical updates, recommended updates, and the service releases for the version of Windows® that you are using prior to installing any TRDI software.

Minimum Computer Hardware Requirements:

- Windows 10®, Windows 8®, Windows 7® Desktop, Laptop, or Netbook computer
- Screen resolution above 1024x768
- One Serial Port (two or more High Speed UART Serial Port recommended)



***VmDas* has special requirements – see the *VmDas User's Guide* for detailed information on computer requirements.**

The computer configuration varies depending of the number of communication ports and the external data refresh rate. Serial communications require a lot of processor resources, and the minimum requirements can vary. A good quality video card is required to operate *VmDas* and *WinADCP* simultaneously. We do not use graphic card 3D functions; however, video memory is needed to display all graphics.

However, with experience we can recommend that:

- If you are using more than two communication ports, you should not use a Celeron processor.
- Intel Pentium III processors work best to operate the ADCP and give access to the display and keyboard without losing ensembles.

Power Overview

Long Ranger / QuarterMaster ADCPs require +20 to 50 VDC to operate.

Power on Cycle

WorkHorse ADCPs require +20 to 50 VDC to operate. A fresh alkaline battery provides +42 VDC. The Lithium battery provides +34 VDC. The power supply or battery pack must be able to handle the inrush current as well. Inrush current is the current required to fully charge up the capacitors when power is applied to the ADCP. The capacitors provide a store of energy for use during transmit. The inrush current is as high as 3 Amps rms. The ADCP will draw this amperage until its capacitors are fully charged.

If the power supply or battery pack limits the current or the power drop on the cable is significant, then the power on cycle will take longer. It can take up to one minute. You do not want the power to shut down during the inrush current draw, as this may not allow the ADCP electronics to start.

AC Power Adapter

The AC power adapter is designed to maintain a 400-ma supply under the ADCP's inrush current. The adapters are 75-Watt supplies, with 48 VDC, 1.5 amp outputs. They will not fall back to 0 amps, 0 volts under a load. Customer provided power supplies might shut themselves down under such a load; when that occurs, the ADCP will not wakeup.

The AC adapter input voltage is sufficient to override the internal Lithium battery voltage (for example, the ADCP will draw all power from the AC adapter even if the Lithium battery is installed and connected). Always use the AC adapter when testing the ADCP to conserve the battery power.



Before using the optional Lithium battery pack, always run the battery's self-test. See [Testing the Lithium Battery Pack](#) for instructions.

Instruments with high inrush currents occasionally trigger the optional Lithium battery pack short circuit detection, which turns the battery off. If this happens, do the following:

- Connect the AC adapter and wait for a minute and then connect the battery pack. Once the ADCP is connected, unplug the AC adapter. The ADCP will work normally after that.

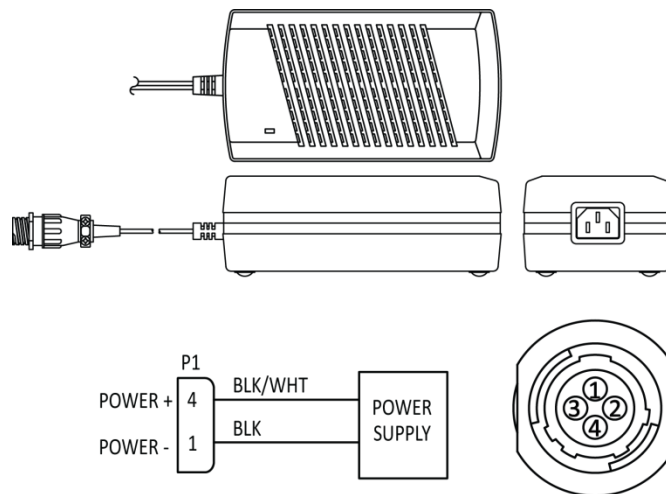

Figure 4. AC Power Adapter

Internal Battery Power Overview

The Long Ranger / QuarterMaster's internal battery supplies +42 VDC. The AC Adapter runs on any standard AC power and supplies +48 VDC to run the ADCP when the batteries are not connected.



The AC Adapter input voltage is sufficient to override the internal battery voltage (for example, the ADCP will draw all power from the AC adapter even if the battery is installed and connected). Always use the AC adapter when testing the ADCP to conserve the battery power.

Keep in mind the following about Long Ranger / QuarterMaster alkaline battery packs:

- TRDI specifies its battery packs to have 450 Watt-hours (Wh) of usable energy at 0°C.
- A Standard ADCP battery packs hold 28 'D-cell' alkaline batteries with a voltage, when new, of approximately 42 VDC.
- When the capacity of a battery pack is 50% used, the voltage (measured across the battery connector) falls to approximately 32 to 35 volts. However, keep in mind that this voltage is not an accurate predictor of remaining capacity.
- Transmitted power increases or decreases depending on the input voltage (within the voltage range of 20 to 50 VDC). A fresh battery provides +42 VDC. Batteries spend most of their life at a nominal voltage of +33 VDC.



The transmitted power is decreased one DB if the input voltage drops from 42 VDC to 33 VDC. For a 600 kHz ADCP, each one DB drop will result in a decrease in range of one default depth cell.

- Batteries should be replaced when the voltage falls below 30 VDC (measured across the battery connector).
- Battery packs differ from one to another.
- Store batteries in a cool dry location (0 to 21 degrees C).
- Do not store batteries inside the ADCP for extended periods. The batteries may leak.
- Use batteries within one year of the manufacture date (use by warning date*).



Do not deploy the system with batteries that are older than the Warning date. It should be noted, that while a battery pack will not be dead after the Warning Date, the actual performance of the battery is in doubt, and TRDI does not warranty any deployment started with a battery pack that is past its Warning date.



TRDI batteries have four dates on them:

Manufacture Date is the date the battery was built and final tested.

TRDI Ship by Date provides the maximum duration that the battery will remain on our shelves before we will ship and is 6 months after our manufacture date.

Warning Date* provides the last date when the battery should be used to start a deployment and is 12 months from the manufacture date.

Expiration Date provides the date when the battery should no longer be considered useful and is 2 years from the manufacture date.

***A battery pack used to start a deployment prior to the Warning Date means that it will perform as expected and provide the required power for any deployment that was created using the TRDI planning module. For example, if your deployment is going to be 12 months long and the battery label shows it is nine months old, it is safe to use the battery.**



Battery replacement induces both single and double cycle compass errors. The compass should be calibrated after replacing the battery pack.

These compass effects can be avoided by using an optional external battery pack. The optional external battery housing holds up to four batteries, and can easily be replaced on-site. If the optional external battery is placed a minimum of 1 meter away from the ADCP, no compass calibration will be required.

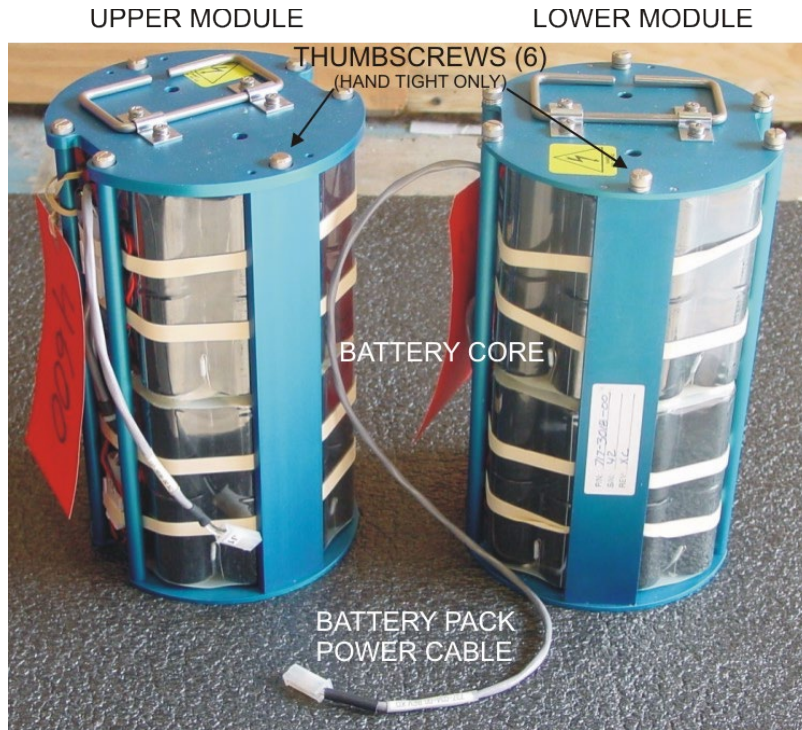

Figure 5. Battery Modules



The upper battery pack module has a thicker and larger diameter topplate as well as a shorter battery pack power cable. This module will not slide down as far into the housing as the lower module.

Setting up the System

Use this section to connect the Long Ranger / QuarterMaster to a computer and establish communications. Install the *TRDI Toolz* software in order to communicate with the ADCP.

Initial Battery Connection

When you first receive your Long Ranger / QuarterMaster, the batteries are installed, but the battery power cables are not connected.

To connect the batteries:

1. Remove the end-cap (see [End-Cap Removal Procedures](#)).
2. The battery pack power cable connectors are tucked around the battery module. Carefully pull them free.
3. Connect the battery pack power cables to the internal I/O cable.
4. Install the end-cap ([End-Cap Replacement](#)).
5. Verify the compass calibration ([Compass Calibration Verification](#)).

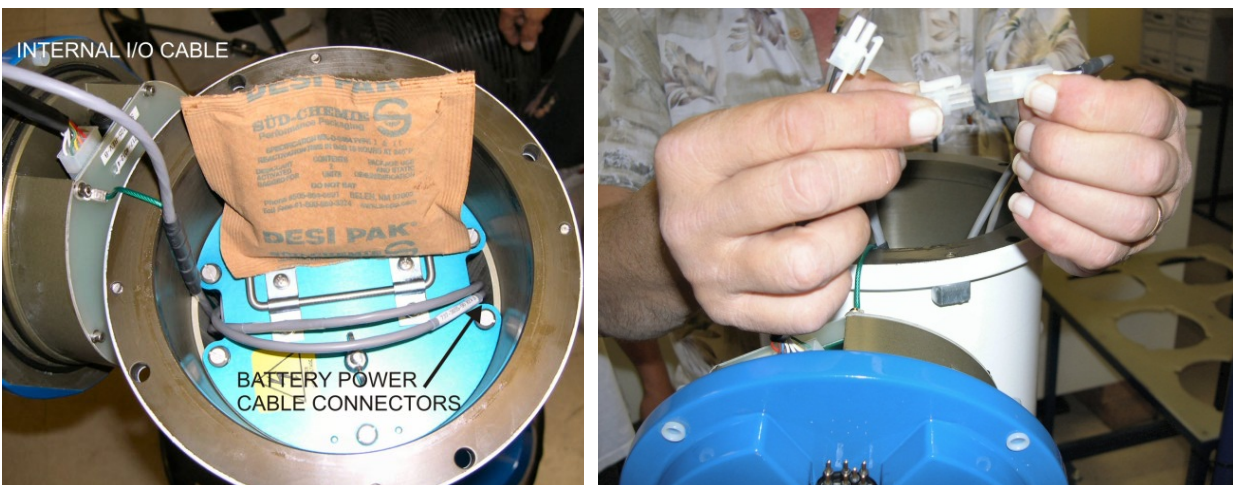



Figure 6. Initial Battery Connection

Set Up the Long Ranger / QuarterMaster ADCP

To set up the Long Ranger / QuarterMaster ADCP:

1. Connect the I/O cable to the Long Ranger / QuarterMaster ADCP. Do so by pushing straight in against the connector. Roll the retaining strap/Cable Clip with O-Ring over the connector.



Place a light amount of dry silicone lubricant spray on the connector pins (rubber portion only). This will make it easier to connect or remove the I/O cable and dummy plug. See [I/O Cable and Dummy Plug](#) for details.

2. Attach the I/O cable to the computer's communication port. The standard communications settings are RS-232, 9600-baud, no parity, 8 data bits and 1 stop bit. Use an RS-422 to RS-232 adapter if the ADCP is configured as RS-422.
3. Connect the AC power adapter to the I/O cable.

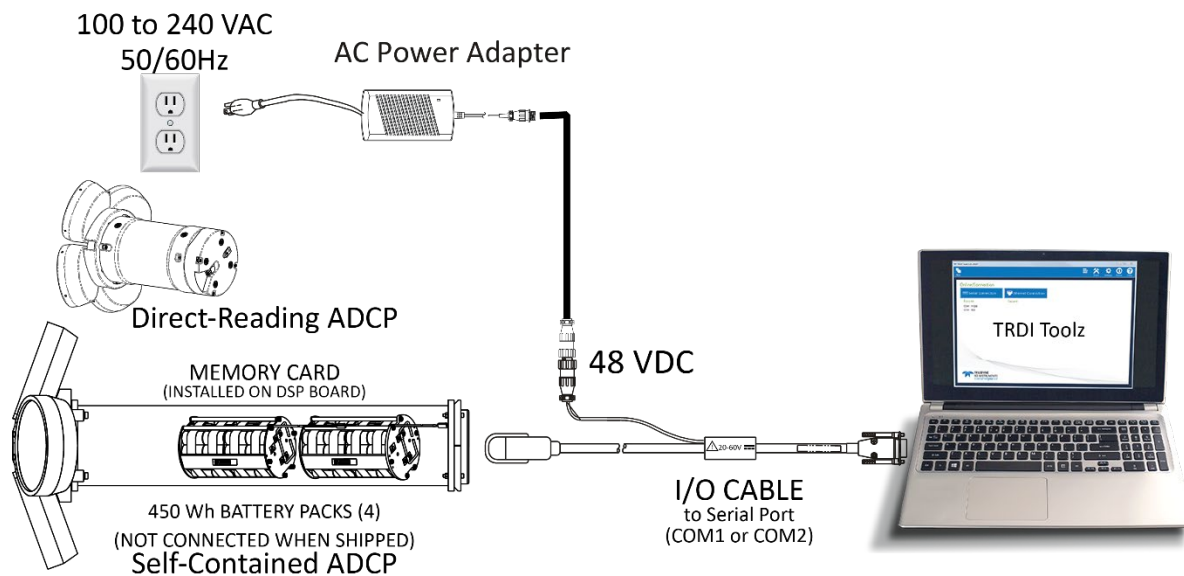



Figure 7. Long Ranger / QuarterMaster Connections



Long Ranger / QuarterMaster batteries are shipped inside the ADCP but not connected. Connect the battery and seal the ADCP before deployment.

For testing, the battery can be disconnected to save battery power. If the battery is connected, use the AC power adapter to override the battery voltage to conserve the battery.

Connecting to the System using TRDI Toolz

To establish communications with the Long Ranger / QuarterMaster:

1. Connect the system and apply power.
2. Start the *TRDI Toolz* software.
3. Select **New Serial Connection**.
4. Enter the ADCP's communication settings. Select the **COM Port** the serial cable is connected to and set the **Baud Rate** from the drop down lists.
5. Click the **Connect** button. Once connected, the button will change to **Disconnect**.
6. Click the **Break** (⚡) button. From the **Break** button drop down menu, select **Soft Break** (= = =). The wakeup banner will display in the terminal window.

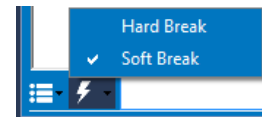
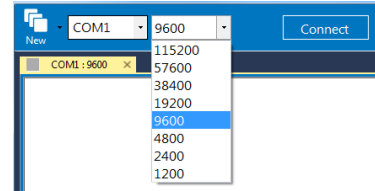

```
[BREAK Wakeup A]
WorkHorse Broadband ADCP Version 50.41
Teledyne RD Instruments (c) 1996-2010
All Rights Reserved.
```

>

 It may be necessary to click inside the terminal window and then click the **Break** button to wake up the system.

 **If you are unsure of the ADCP's baud rate, use Tools, Find ADCP. *TRDI Toolz* will try different baud rates until it connects to the ADCP.**

```
>{ i_7 φ² n_|| ² ² jñ~ªñδgJ Checking 9600 baud rate
Checking 115200 baud rate
==
WorkHorse Broadband ADCP Version 50.41
Teledyne RD Instruments (c) 1996-2010
All Rights Reserved.
```

>

 For help on using *TRDI Toolz*, click the  icon.

 **Long Ranger / QuarterMaster batteries are shipped inside the ADCP but not connected. Connect the battery and seal the ADCP before deployment.**

Connecting to the System using BBTalk

To connect to the Long Ranger / QuarterMaster ADCP using *BBTalk*:

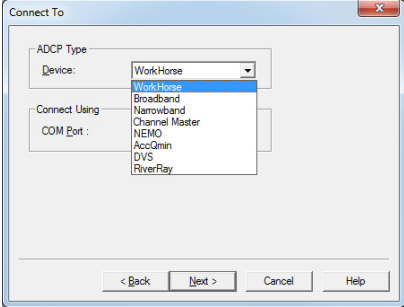
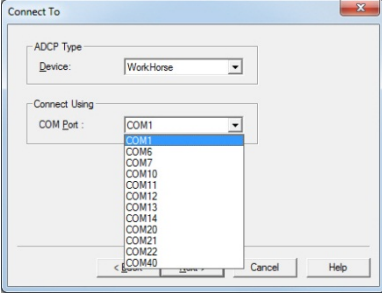
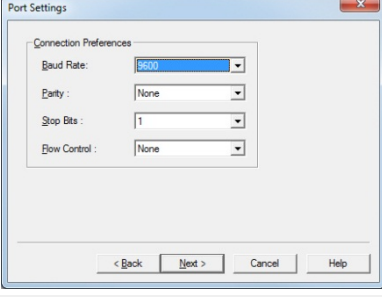
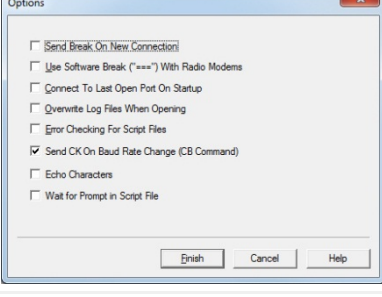
	<p>Start <i>BBTalk</i></p> <p>Start the <i>BBTalk</i> program (for help on using <i>BBTalk</i>, see the RDI Tools User's Guide).</p> <p>On the Connect To screen, select WorkHorse.</p>
	<p>Select the COM port the Long Ranger / QuarterMaster ADCP cable is connected to.</p> <p>Click Next.</p>
	<p>Enter the Baud Rate, Parity, Stop Bits, and Flow Control. If you are unsure of the settings, leave them at the default settings as shown.</p> <p>Click Next.</p>
	<p>Click Finish.</p>

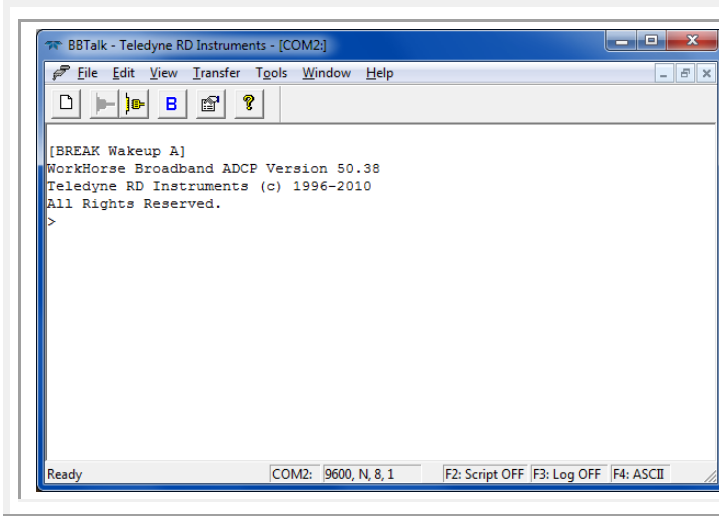

Wakeup

On the **File** menu, click **Break** (you can also press the **End** key to send a break or press the **B** button on the Toolbar).

You should see the wakeup message appear on the log file window.

If your ADCP does not respond, check the serial port, cables, AC power, and battery connection (Self-Contained only). If necessary, refer to the [Troubleshooting](#) section.



Long Ranger / QuarterMaster batteries are shipped inside the ADCP but not connected. Connect the battery and seal the ADCP before deployment.

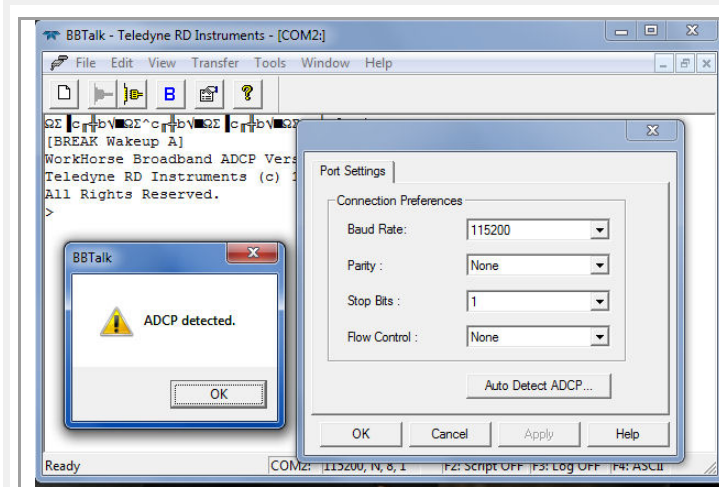

If the wakeup message is not readable or visible:

On the **File** menu, click **Properties**.

Click the **Auto Detect ADCP** button.

Click **OK** when the ADCP is detected. Try to wake up the ADCP again.





Both *BBTalk* and the ADCP must use the same Baud rate.

Changing the Baud Rate in the ADCPs

The ADCP can be set to communicate at baud rates from 300 to 115200. The factory default baud rate is always 9600 baud. The baud rate is controlled via the CB-command. The following procedure explains how to set the baud rate and save it in the ADCP. This procedure assumes that you will be using the program *TRDI Toolz* or *BBTalk* that is supplied by Teledyne RD Instruments.

<pre>[BREAK Wakeup A] WorkHorse Broadband ADCP Version 50.38 Teledyne RD Instruments (c) 1996-2010 All Rights Reserved. >cr1 [Parameters set to FACTORY defaults] ></pre>	<p>Connect the ADCP to the computer and apply power. Start the <i>TRDI Toolz</i> or <i>BBTalk</i> program and establish communications with the ADCP. Wakeup the ADCP by sending a break.</p> <p>At the ">" prompt in the communication window, type CR1 then press the Enter key. This will set the ADCP to the factory default settings.</p>
---	--

<table border="1" style="width: 100%; border-collapse: collapse;"> <thead> <tr style="background-color: #002060; color: white;"> <th style="text-align: left;">BAUD RATE</th> <th style="text-align: left;">CB-command</th> </tr> </thead> <tbody> <tr><td>300</td><td>CB011</td></tr> <tr><td>1200</td><td>CB111</td></tr> <tr><td>2400</td><td>CB211</td></tr> <tr><td>4800</td><td>CB311</td></tr> <tr style="background-color: #add8e6;"><td>9600</td><td>CB411 (Default)</td></tr> <tr><td>19200</td><td>CB511</td></tr> <tr><td>38400</td><td>CB611</td></tr> <tr><td>57600</td><td>CB711</td></tr> <tr style="background-color: #ffcc00;"><td>115200</td><td>CB811</td></tr> </tbody> </table>	BAUD RATE	CB-command	300	CB011	1200	CB111	2400	CB211	4800	CB311	9600	CB411 (Default)	19200	CB511	38400	CB611	57600	CB711	115200	CB811	<p>Send the CB-command that selects the baud rate want to use. The table on the left shows the CB-command settings for different baud rates with no parity and 1 stop bit.</p> <p>For example, to change the baud rate to 115200, at the ">" prompt in the communication window, type cb811 then press the Enter key.</p> <p> The CB? command will identify the communication setting.</p>
BAUD RATE	CB-command																				
300	CB011																				
1200	CB111																				
2400	CB211																				
4800	CB311																				
9600	CB411 (Default)																				
19200	CB511																				
38400	CB611																				
57600	CB711																				
115200	CB811																				

<pre>>cb? CB = 411 ----- Serial Port Control (Baud [4=9600]; Par; Stop) >cb811 >CK [Parameters saved as USER defaults] >cb? CB = 811 ----- Serial Port Control (Baud [8=115200]; Par; Stop) ></pre>	<p>The ADCP will send the command CK to save the new baud rate setting.</p> <p>Exit <i>TRDI Toolz/BBTalk</i>.</p> <p>The ADCP is now set for the new baud rate. The baud rate will stay at this setting until you change it back with the CB command.</p> <p> Exit <i>TRDI Toolz</i> or <i>BBTalk</i> so the communication port is available for use with other programs.</p>
--	--

Caring for your System

This section contains a list of items you should be aware of every time you handle, use, or deploy your Long Ranger / QuarterMaster. *Please refer to this list often.*

General Handling Guidelines

- Never set the transducer on a hard or rough surface. **The urethane faces may be damaged.**
- Always remove the retaining strap/Cable Clip with O-Ring on the underwater-connect cable and dummy plug when disconnecting them. **Failure to do so will break the retainer strap.**
- Do not apply any upward force on the end-cap connector as the I/O cable is being disconnected. **Stressing the connector may cause the ADCP to flood.** Read the Installation section for details on disconnecting the I/O cable.
- Do not expose the transducer faces to prolonged sunlight. **The urethane faces may develop cracks.** Cover the transducer faces on the Long Ranger / QuarterMaster if it will be exposed to sunlight.
- Do not expose the I/O connector to prolonged sunlight. **The plastic may become brittle.** Cover the connector on the Long Ranger / QuarterMaster if it will be exposed to sunlight.
- Do not store the ADCP in temperatures over 60 degrees C with the batteries removed. **The urethane faces may be damaged.**
- Store batteries in a **cool dry location** (0 to 21 degrees C). If the batteries are installed in the ADCP, do not store the ADCP in temperatures over 21 degrees C.
- Do not store batteries inside the ADCP for extended periods. **The batteries may leak.**
- **Use batteries within one year of the Manufacture date (use by Warning date).** A battery pack used to start a deployment prior to the Warning Date means that it will perform as expected and provide the required power for any deployment that was created using the TRDI planning module. For example, if your deployment is going to be 12 months long and the battery label shows it is nine months old, it is safe to use the battery.
- Vent the system before opening by loosening the hardware on the housing. **If the ADCP flooded, there may be gas under pressure inside the housing.**
- Do not scratch or damage the O-ring surfaces or grooves. **If scratches or damage exists, they may provide a leakage path and cause the ADCP to flood.** Do not risk a deployment with damaged O-ring surfaces.
- Do not lift or support a Long Ranger / QuarterMaster by the external I/O cable. **The connector or cable will break.**
- Weight in air for a LongRanger/QuarterMaster system is between 38.5 Kg (85 pounds) to 124.7 Kg (275 pounds). **Use lifting aids and proper lifting techniques when moving.**

Assembly Guidelines

- Read the Maintenance section for details on Long Ranger / QuarterMaster re-assembly. Make sure the housing assembly O-ring stays in the groove when you re-assemble the Long Ranger / QuarterMaster. Tighten the hardware as specified. **Loose, missing, stripped hardware, or a damaged O-ring can cause the Long Ranger / QuarterMaster transducer to flood.**
- Use light amounts of silicone lubricant (such as 3M™ Silicone Lubricant (Dry Type) ID No: 62-4678-4930-3) on both the male pins and female socket to help seat the cable connectors. Wipe off excessive silicone spray from the metal portions of the pins. **Regular lubrication is required: Apply dry type silicone lubricant prior to each connection.**
- Do not connect or disconnect the I/O cable with power applied. When you connect the cable with power applied, you may see a small spark. **The connector pins may become pitted and worn.**
- The Long Ranger / QuarterMaster I/O cable may be connected while slightly wet; **do not connect under water.**

Deployment Guidelines

- Read the TRDI Toolz help file and WinSC Software User's Guides. **These guides have tutorials to help you learn how to use the ADCP.**
- Long Ranger / QuarterMaster batteries are shipped inside the ADCP but not connected. **Connect the battery and seal the ADCP before deployment.**
- Align the compass whenever the batteries are replaced, the recorder module is replaced, or when any ferrous metals are relocated inside or around the Long Ranger / QuarterMaster housing. **Ferro-magnetic materials affect the compass.**



When the batteries are replaced the compass must be calibrated with the AF command (see [Compass Calibration](#)).

- The AC power adapter is not designed to withstand water. **Use caution when using on decks in wet conditions.**
- Avoid using ferro-magnetic materials in the mounting fixtures or near the Long Ranger / QuarterMaster. **Ferro-magnetic materials affect the compass.**

Chapter 2

INSTALLATION



In this chapter, you will learn:

- How to connect/disconnect the I/O cable
- How to connect the optional external batter case
- Cable wiring diagrams
- Available mounts for the ADCP

Using the Cable Clips

New dummy plugs and cables no longer use a molded retaining strap. To use the cable clips:

1. Remove the broken retaining strap if needed.
2. Snap the clip onto the cable or dummy plug.
 - Black clip & 2-137 O-ring = cables
 - White clip & 2-130 O-ring = dummy plugs
3. Route the O-ring through the clip. Connect the cable/dummy plug and then stretch the O-ring over the connector.

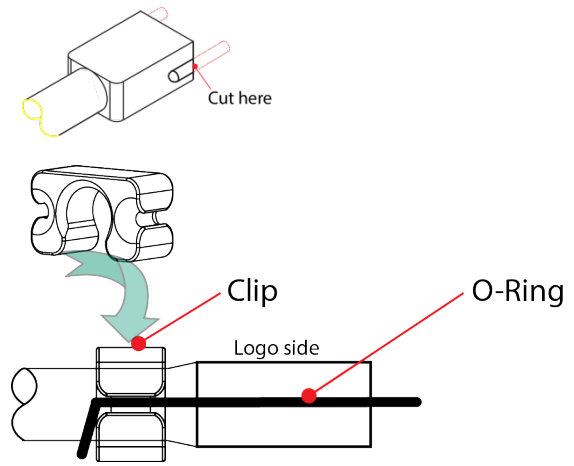
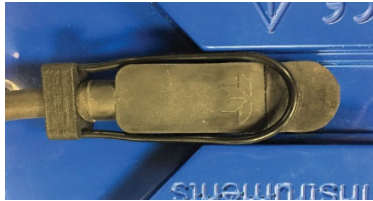

I/O Cable and Dummy Plug

The underwater connector (on the housing) and the I/O cable and dummy plug are molded wet-mate connectors.



The dummy plugs should be installed any time the cable is removed. Use the dummy plug when the ADCP is in storage or is being handled.



When disconnecting or connecting the Long Ranger / QuarterMaster I/O cable, do not apply any upward force on the connector. Applying an upward angle as the cable is disconnected or connected puts stress on the connector. This may cause several serious problems:

- a) The connector or connector pins can crack.
- b) The O-ring on the bottom of the connector can be damaged.
- c) The molded urethane on the connector may separate from the brass insert.

If the connector is damaged in any of these ways, your Long Ranger / QuarterMaster will flood.

Disconnecting the Cable

To disconnect the cable:

1. Release the retaining strap by pulling it over the connector.
2. Grasp the cable close to the housing (see Figure 8). Your thumb should rest on top of the connector or against the edge of the housing. *Do not try to fit your hand under the cable as it passes over the housing.* This is what causes the upward force!
3. Pull the cable straight out away from the housing with a gentle rocking motion. Do not apply any upward force on the connector as it is being disconnected.

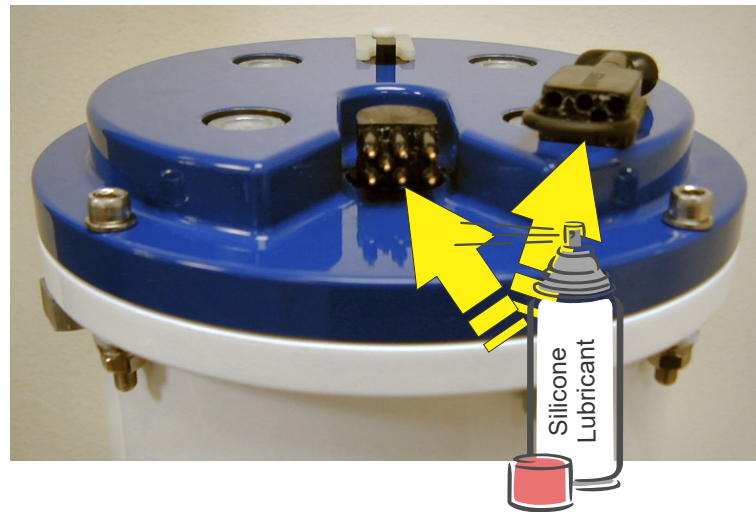

Figure 8. Removing the I/O Cable

Connecting the Cable

To connect the cable:

1. Check all pins for signs of corrosion (greenish oxidation, black deposits, or pitting).
2. Use light amounts of silicone lubricant (such as 3M™ Silicone Lubricant (Dry Type) ID No: 62-4678-4930-3) on both the male pins and female socket to help seat the cable connectors. Wipe off excessive silicone spray from the metal portions of the pins. **Regular lubrication is required:** Apply dry type silicone lubricant prior to each connection.



When the cable is connected without any lubricant, excessive force is needed to fully seat or remove the connector. This can cause several serious problems:



- The neoprene rubber portion of the contact pin may tear from the metal pin.
- Wiggling the cable side-to-side to overcome the friction as it is connected or disconnected may cause the neoprene rubber to tear or create pin-holes on the side of the connector.

As a result of any damage to the neoprene rubber, corrosion may occur on current carrying pins.

3. Gently push the cable straight in toward the connector. Do not apply any upward force on the connector as it is being connected.
4. Roll the retaining strap/Cable Clip with O-Ring over the connector.

Connecting the External Battery Case

The optional External Battery Pack holds four 450 Watt-hours (Wh) batteries. The WorkHorse external battery case holds two battery cores. To avoid affecting the compass, place the external battery at least one meter away from the Long Ranger / QuarterMaster ADCP.

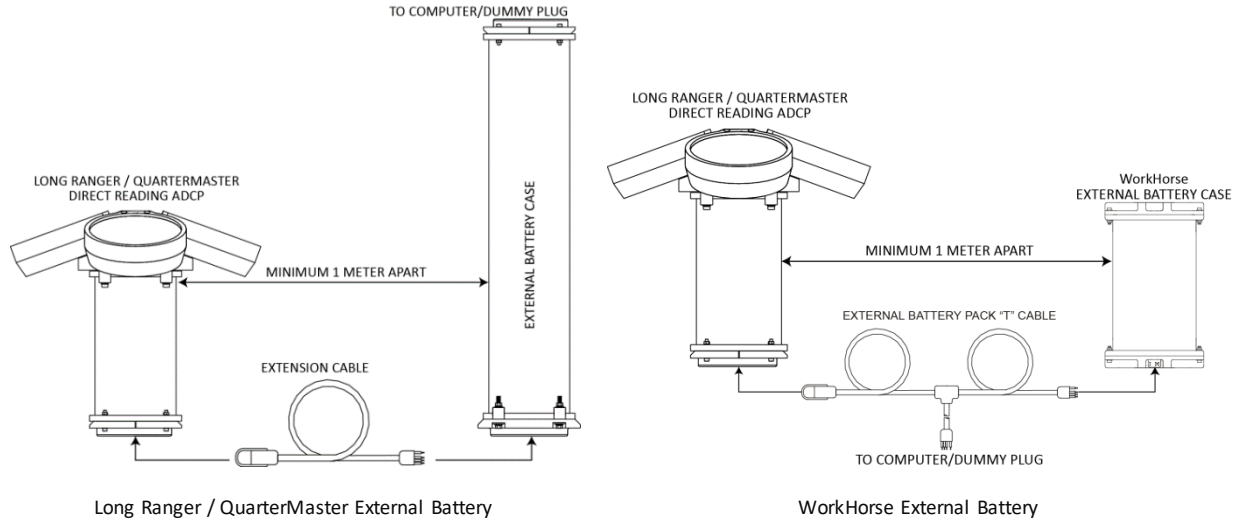

Figure 9. External Battery Case Connection

 **The WorkHorse External Battery Case requires the “T” cable for connection. However, the “T” cable will also work with the Long Ranger / QuarterMaster External Battery Case.**

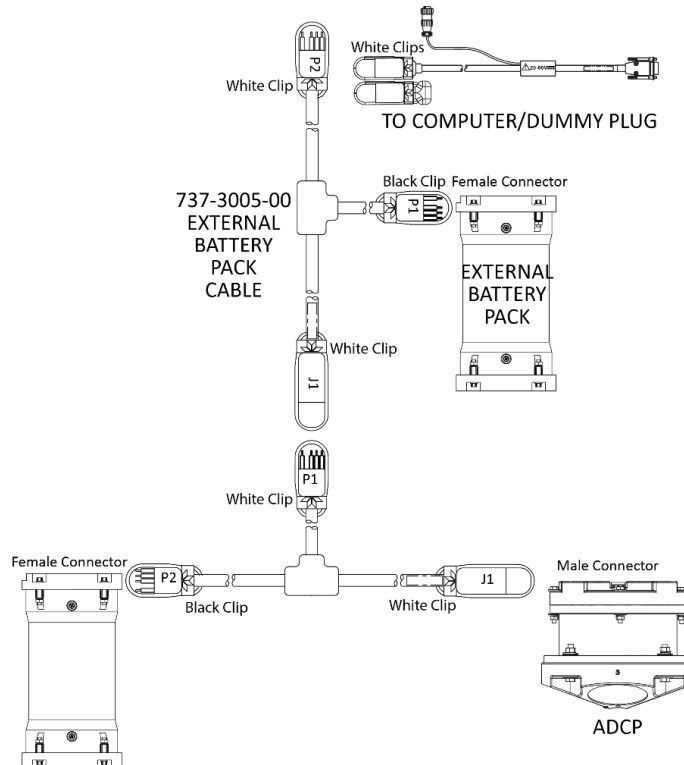

Figure 10. External Battery Pack Connection using a WorkHorse External Battery



J1 plug equipped with white clip and Long O-ring
 P1 plug equipped with white clip and Long O-ring
 P2 Plug equipped with black clip and long O-ring



Spare cable and dummy plug clips and O-rings are included in the spare parts kits.



The 3rd plug on the Y cable may not be used when there is only one External battery case or when the customer is not using a direct connection with the ADCP. In this case, use the Dummy plug from the ADCP to protect the 3rd plug on the Y cable.



For the P1 plug on the Y Cable 737-3005-00, use two white clip with the long O-ring. This solution works for both the cable connector or for the Dummy plug (New and old design) when you are not using the 3rd Plug on the Y cable.



Routing Cables

Use care when routing these cables through bulkheads, deck plates, cable runs, and watertight spaces. Make allowances in cable length and engineering design plans for cable routing. When necessary, use strain reliefs on the cables.

The input/output (I/O) cable connects the ADCP to the computer. TRDI delivers the cable with both connectors attached. The transducer-end connector is molded on, so you can use it below the waterline. The cable is custom-made in lengths specified by the user. You may also need to route External Battery case cables. Route these cables so:

- You can install it with the connectors attached.
- It does not have kinks or sharp bends.
- Protect the cables with hose if zip-ties are used to secure them to structures (see Figure 11 and Figure 12).
- You can easily replace the cable if it fails.



Figure 11. Do not use Zip-Ties Directly on Cables



When attaching the ADCP cables to your mount, do not zip-tie the cables directly to the structure. Zip-ties slowly cut through the cable's outer jacket and cause leaks.



Figure 12. Cables Protected with Abrasion Resistant Sleeving

Cable Wiring Diagrams

This section has information on Long Ranger / QuarterMaster cabling. Special user-requests may cause changes to the basic wiring system and may not be shown here. If you feel there is a conflict, contact TRDI for specific information about your system. The following figures show various Long Ranger / QuarterMaster cable locations, connectors, and pin-outs.



Where shown, the color code is for reference only; your cable may be different.

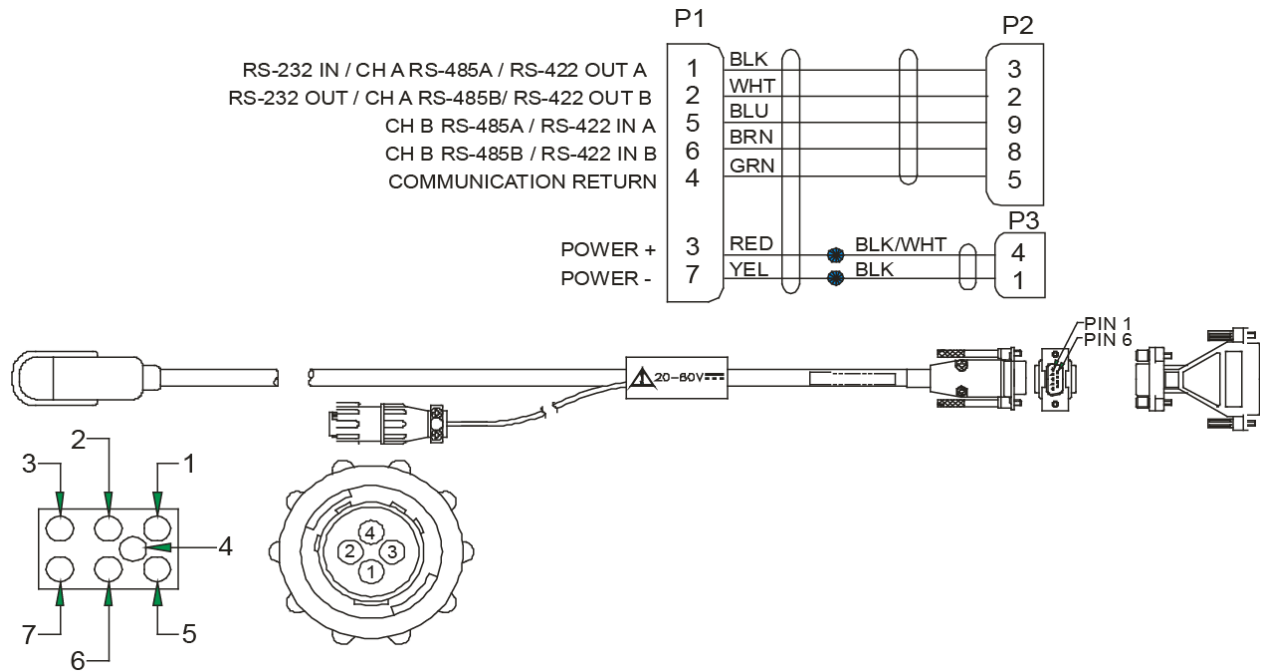



Figure 13. Long Ranger / QuarterMaster I/O Cable Wiring

 Where shown, IN refers to signals going into the ADCP and OUT refers to signals coming out of the ADCP.

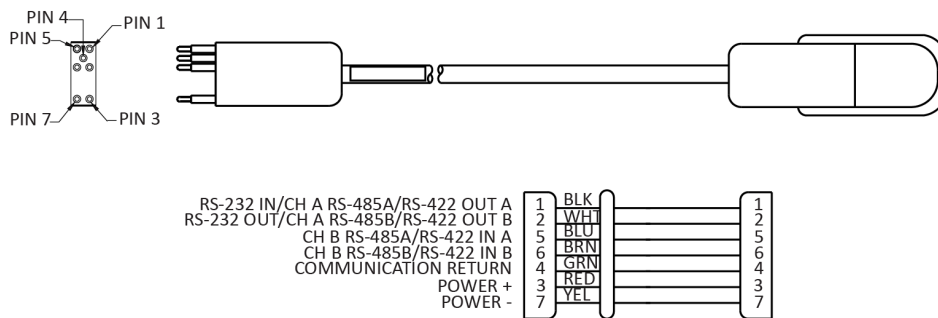

Figure 14. Extension Cable

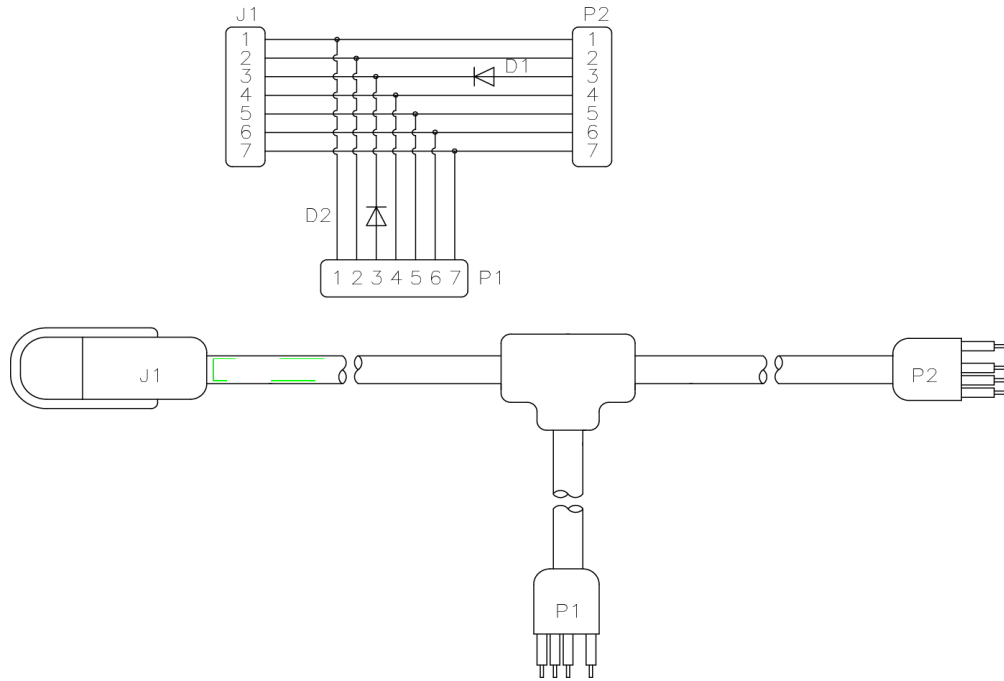

Figure 15. WorkHorse External Battery Pack "T" Cable

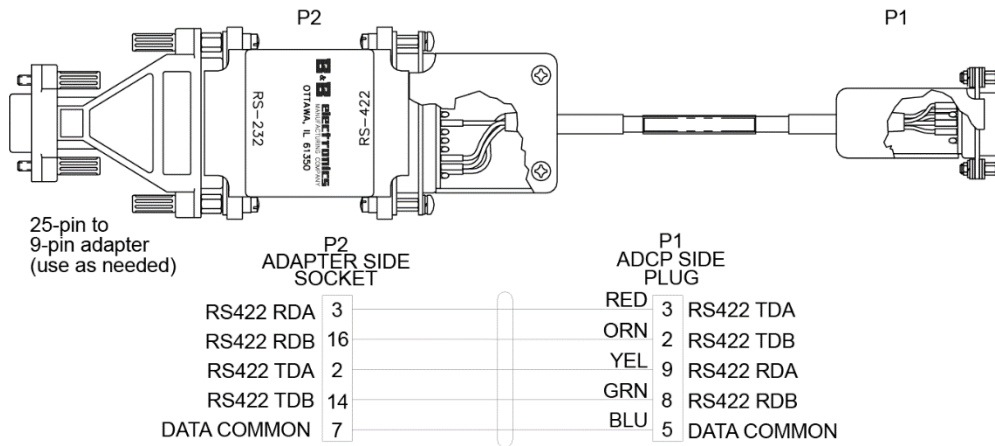

Figure 16. RS232-to-RS422 Converter Wiring (25-Pin to 9-Pin)

Mounting the Instrument

The Long Ranger / QuarterMaster can use bottom mounts, buoys, or load cages. If you are using a fixed mount, use clamps that grip the circumference of the housing. See the [Outline Installation Drawings](#) for dimensions.

Bottom Mounts

Bottom mounts can range from simple PVC frames to Trawl Resistant Bottom Mounts. Below is a sample of some of the types of bottom mounts available for Long Ranger / QuarterMaster ADCPs.

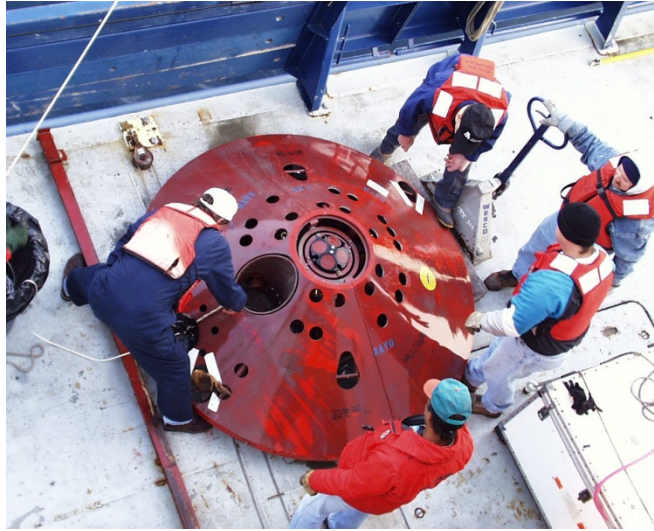

Figure 17. Trawl Resistant Bottom Mount

Photo courtesy of Maureen Wieler, Mooring Systems.

Buoy Mounts and Load Cages

Buoy mounts and load cage frames are designed to allow the Long Ranger / QuarterMaster to profile unobstructed by the mooring hardware. Below is a sample of some of the types of buoy and load cage mounts available for Long Ranger / QuarterMaster ADCPs.



Figure 18. Long Ranger / QuarterMaster being Deployed

Photo courtesy of Paul Devine, Teledyne RD Instruments

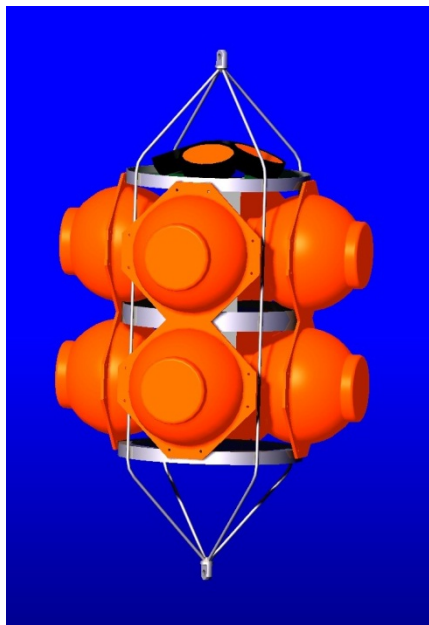

Figure 19. Deep-Water Mount

Photo courtesy of the Oceanscience Group.



Figure 20. Buoy Mount with External Battery

Photo courtesy of Maureen Wieler, Mooring Systems.



Figure 21. Subsurface Buoy

Photo courtesy of Patrick Lefeuve, Technicap. The Subsurface buoy was developed by BMTI and Technicap.



Figure 22. Buoy Mount

Photo courtesy of Flotation Technologies.

Fixed Mount

The Direct-Reading Long Ranger / QuarterMaster can be used for real time data collection from a stationary platform (such as from an oil platform or from the bottom looking up and wired to shore).

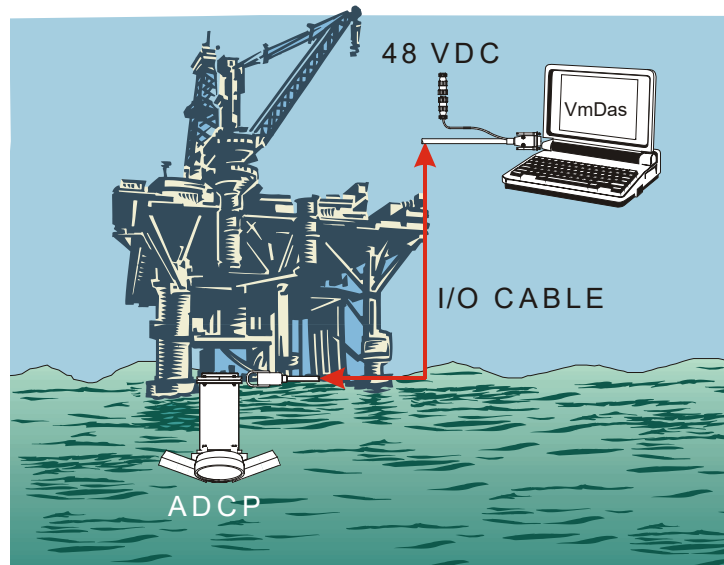
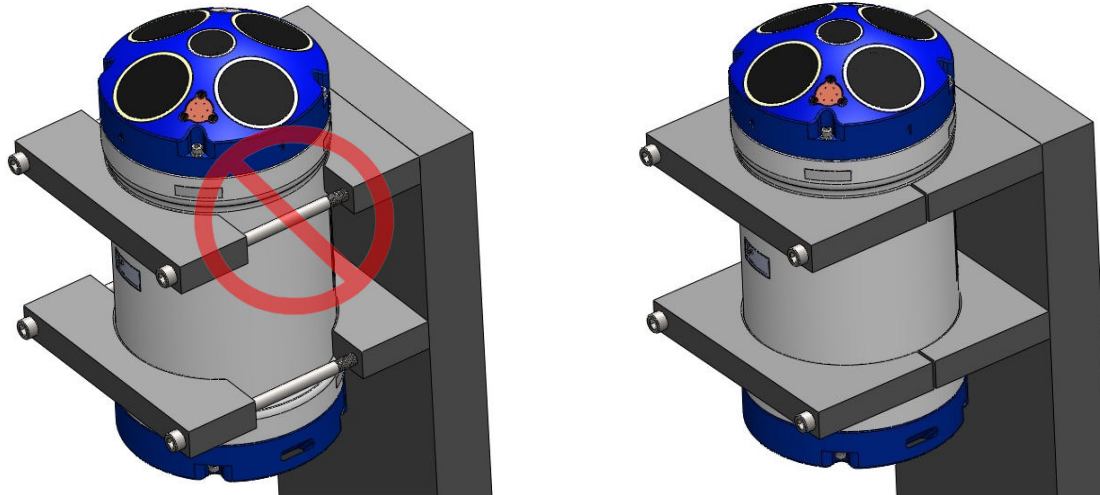

Figure 23. Direct-Reading Configuration

If you are mounting the instrument to a fixed structure, use clamps that grip the circumference of the housing.



Poor Design	Good Design
When clamping the Long Ranger / QuarterMaster to a mount, the clamp must not have a large gap between the front and rear clamp. Using this type of design can cause the housing to deform or even break if the clamps are over tightened. This will cause the ADCP to flood.	Design clamps that fully surround the housing. Design the gap as small as possible so that when the clamp is fully tightened it will not deform the housing or cause excessive pressure on the housing.

Figure 24. Fixed Mount Clamp Design

Fixed Mount Periodic Maintenance

The Maintenance section explains routine maintenance procedures. You rarely need access to the electronics inside the transducer head. However, one external maintenance item is important enough to mention here as it may affect how you install the transducer.

Objects deployed within about 100 meters (328 feet) of the surface are subject to the buildup of organic sea life (biofouling). Soft-bodied organisms usually cause no problems, but hard barnacle shells can cut through the urethane transducer face causing transducer failure and leakage into the transducer (see Figure 25).

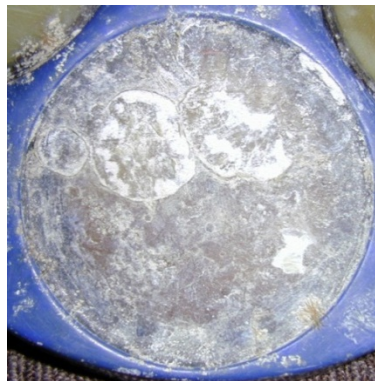

Figure 25. Barnacle Damage to Urethane Face

The best-known way to control biofouling is cleaning the Long Ranger / QuarterMaster transducer faces often. However, in many cases this is not possible. The other alternatives include the use of a window or some sort of anti-foulant protection.

Some of our users have had success applying a thin coat (≈ 4 mm; ≈ 0.16 in.) of either a 50:50 mix of chili powder and Vaseline or chili powder and silicone grease to the transducer faces. The chili powder should be the hottest that can be found. Water flowing across the transducers will wash this mix away over time. The silicone mixture tends to last longer.

Some organizations may decide to use antifouling grease (see [Preventing Biofouling](#)). However, most antifouling greases are toxic and may cause problems. Recent tests suggest antifouling grease may cause the urethane on the transducer faces to develop cracks. Warmer temperatures accelerate this effect.

The other method is to use antifoulant paint (see [Antifouling Paints](#)).

Chapter 3

DATA COLLECTION



In this chapter, you will learn:

- Collecting Self-Contained Data
- Collecting Real-Time Data

Collecting Self-Contained Data

WinSC works as a shell program to launch the PlanADCP program. PlanADCP is designed to create a command file that will be used to set up a Long Ranger / QuarterMaster ADCP for collecting data. In this example we will start WinSC, use PlanADCP to develop the command file, and then go back to the WinSC program to continue with the testing, deployment, and recovery of data.

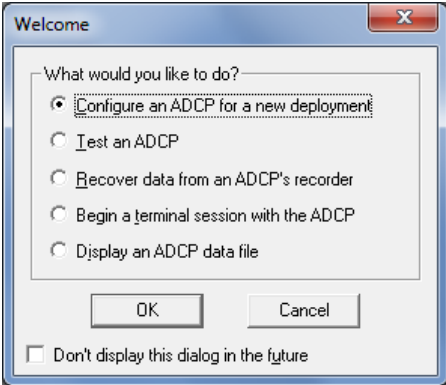

Start WinSC.
Select **Configure an ADCP for a new deployment** and click **OK**.

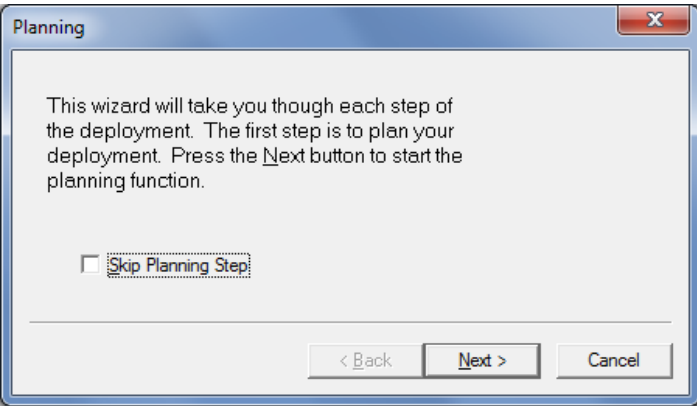

Planning

The first step of the deployment wizard will start PlanADCP.
Click **Next** to continue.

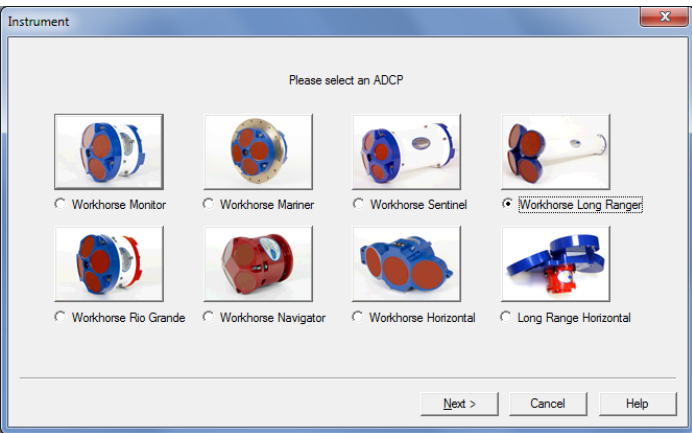

Instrument

Select the type of ADCP you want to create a command file for.
Click **Next** to continue.

 Select **WorkHorse Monitor** (direct reading) or **WorkHorse Sentinel** (self-contained) and set the frequency to 150 kHz for a QuarterMaster ADCP.

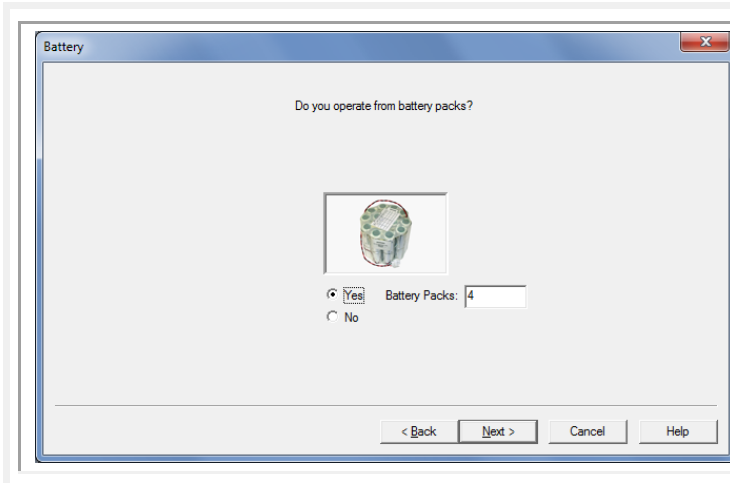

Battery

Select if the Long Ranger / QuarterMaster has internal batteries. If you select **Yes**, then enter the number of battery packs you are going to use.

Click **Next** to continue.

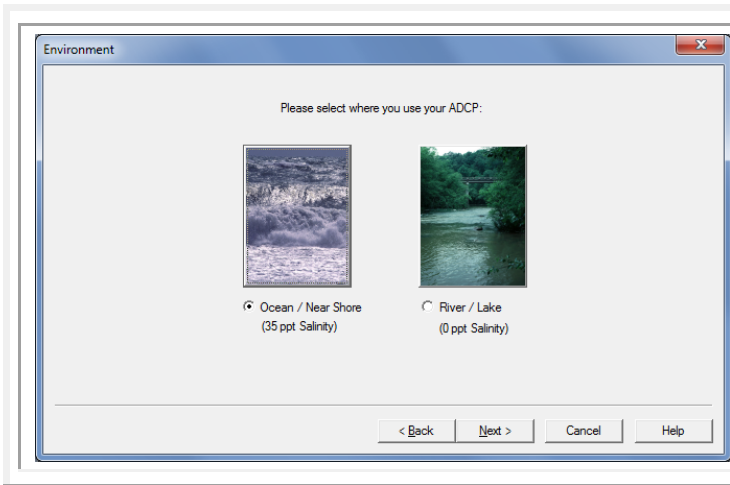

Environment

Select **Ocean/Near Shore** or **River/Lake** to set the salinity. Water salinity affects the maximum range. Salt water is typically 35 ppt, fresh water is 0 ppt.

Click **Next** to continue.

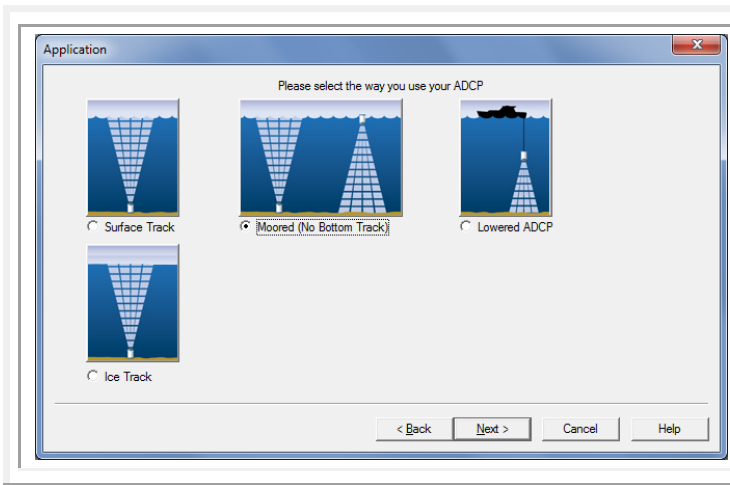

Application

Select **Moored (No Bottom Track)** for a self-contained deployment.

Click **Next** to continue.



For Lowered ADCP and Ice Track deployments, see the LADCP User's Guide.

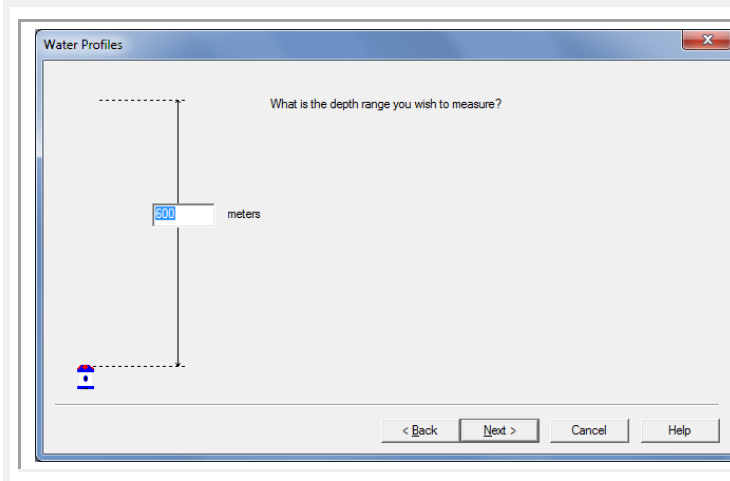

Water Profiles

Select the depth range you wish to measure. The maximum depth range is dependent on the ADCP frequency, water salinity, water temperature, and the depth of the Long Ranger / QuarterMaster. Click **Next** to continue.

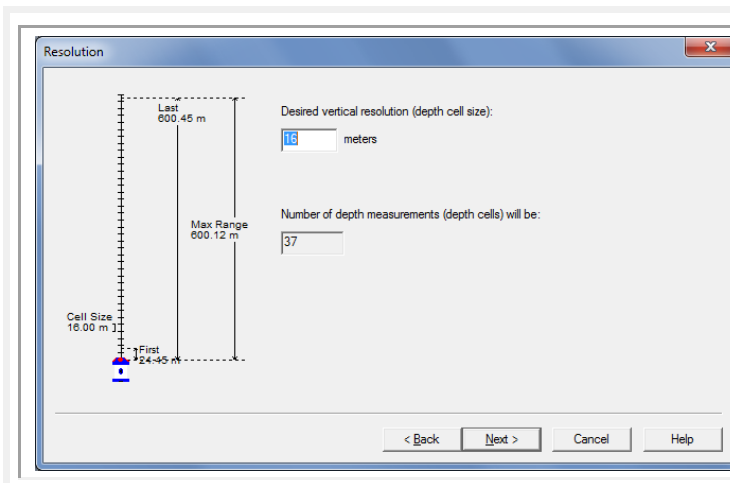

Resolution

Set the depth cell (bin) size. Adjust the depth cell (bin) size as necessary to get at least 10 depth cells (bins). A larger depth cell (bin) size decreases the standard deviation, but shallow water situations may need to use small depth cells (bins) to get more data points.

PlanADCP will set the number of depth cells (bins) so that the consequence *last depth cell (bin) range* is approximately 10% greater than the depth range set in the previous step.

Click **Next** to continue.

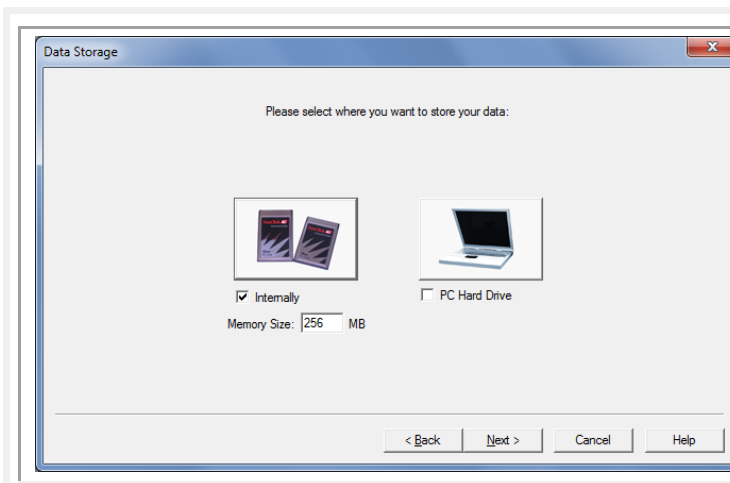

Data Storage

Select where to store the data. Data can be stored internally, sent out the serial port, or both. If you selected **Internally**, enter the amount of memory installed.

Click **Next** to continue.

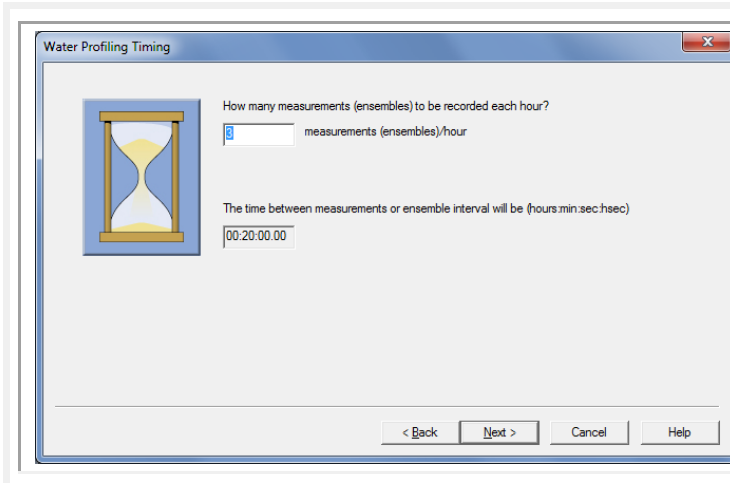

Water Profiling Timing

Select how many ensembles per hour you want to record.

Click **Next** to continue.

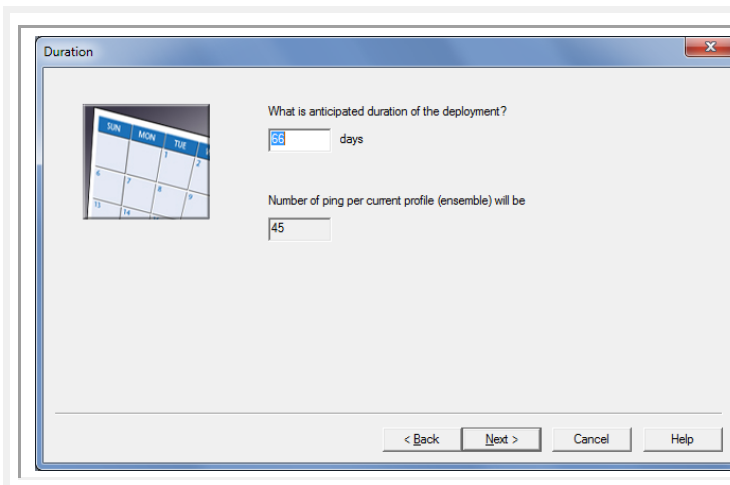

Duration

Enter the expected duration of the WorkHorse deployment from the time of the first water profiling ping (either immediately or first ping date/time). This duration *does not* produce a command to instruct the WorkHorse to stop data collection; it is for estimating consequences only. This duration is used to estimate the following *consequences*:

- Battery usage
- Ensembles
- Storage required

Click **Next** to continue.

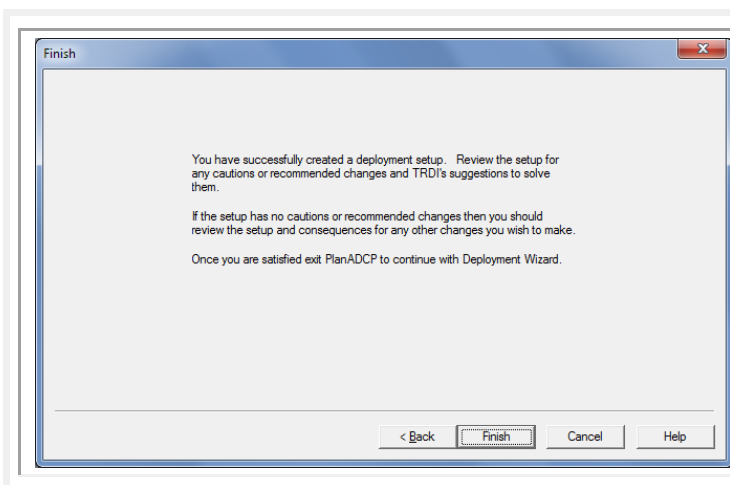

The wizard is now finished.

Click **Finish**.

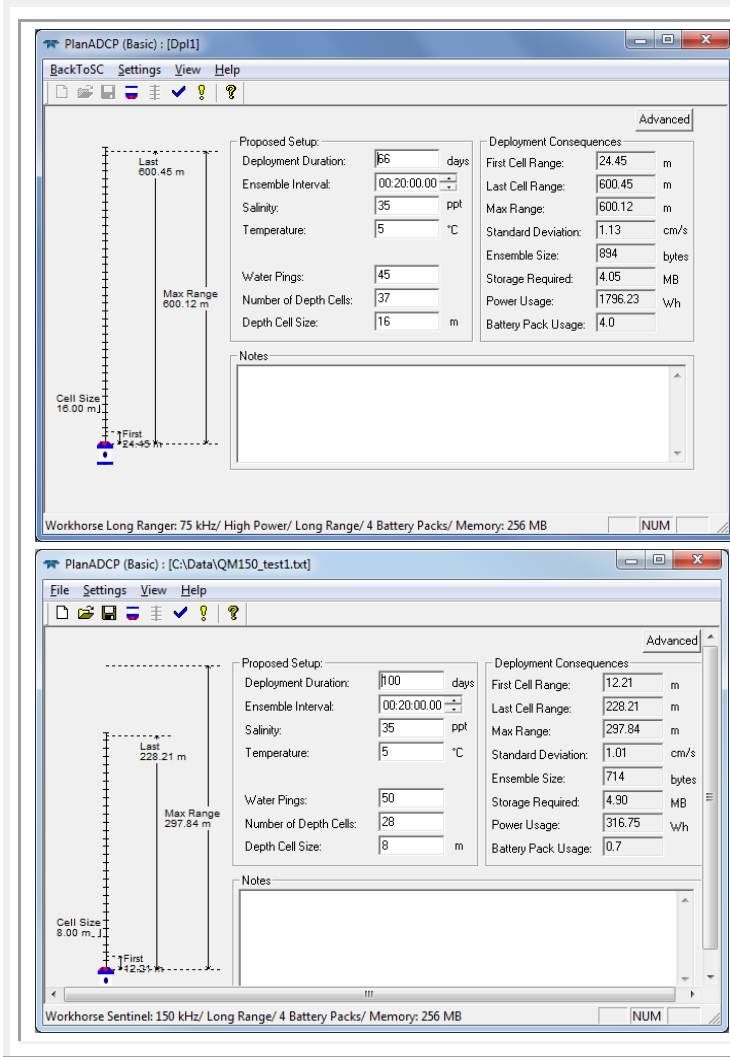

The *PlanADCP* (Basic) Screen opens using the settings you selected with the wizard.

Review the consequences (see the WinSC and *PlanADCP* User's Guide for details).

On the *PlanADCP* (Basic) Screen click the **Advanced** button to bring up the **Advanced** setting screen.



The 6000 meter extended range QuarterMaster is not supported by *PlanADCP*. To estimate the power consumption of the extended range QuarterMaster, plan for a standard WorkHorse 150 kHz and multiply the energy consumed by 1.5 to 1.75.

For example, a 6000 meter extended range QuarterMaster would calculate the power usage as $316.75 \times 1.75 = 554.3125$ Wh.

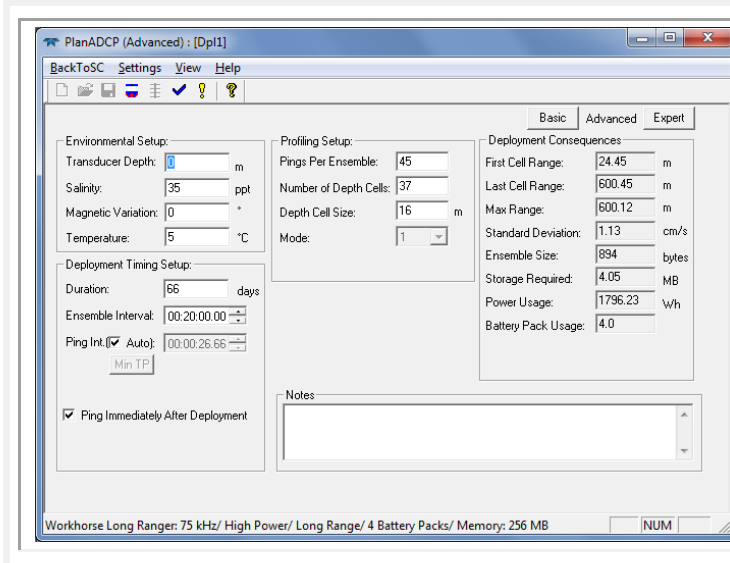

Advanced Screen

Uncheck the **Ping Immediately After Deployment** box and enter a date and time you want the Long Ranger / QuarterMaster to begin pinging.



Start sample intervals on the minute by using a delayed start up. Instead of having your 10-minute sample intervals start at 12:36:47, delay startup a few minutes to have samples start at 13:00:00.

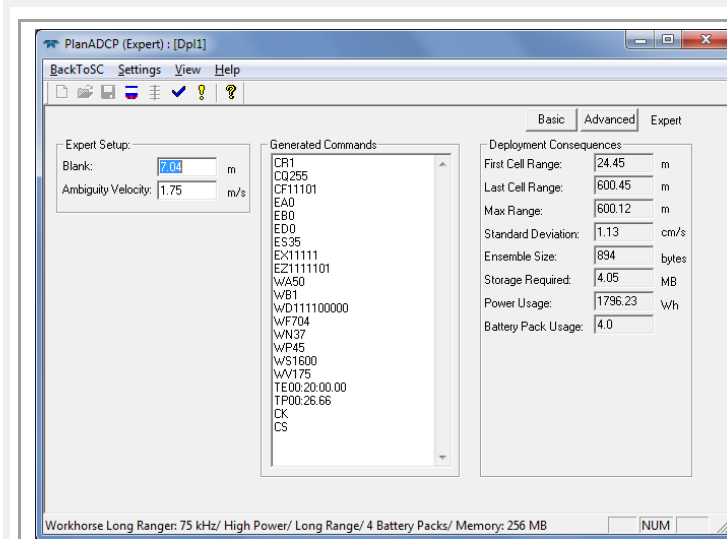

Expert Screen

On the *PlanADCP* (Advanced) Screen click the **Expert** button to bring up the **Expert** setting screen.

You can view the commands that will be sent to the Long Ranger / QuarterMaster.

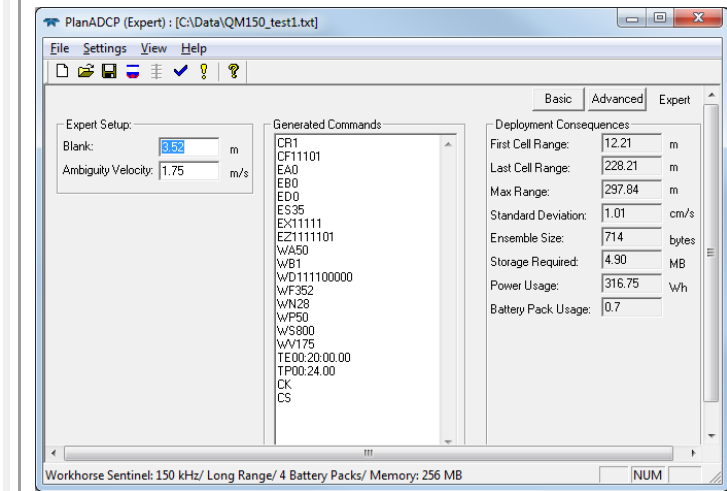

For 75 kHz Long Ranger systems, set the Power setting (CQ command) and bandwidth (WB command) in *PlanADCP* through the hardware selection page. See the *WinSC* and *PlanADCP* User's Guide for details.

The Power setting is used on the 75 kHz Long Ranger only. Although the QuarterMaster ADCP allows the CQ command to be set to values other than the default, the CQ command has no effect and is not supported by *PlanADCP*.

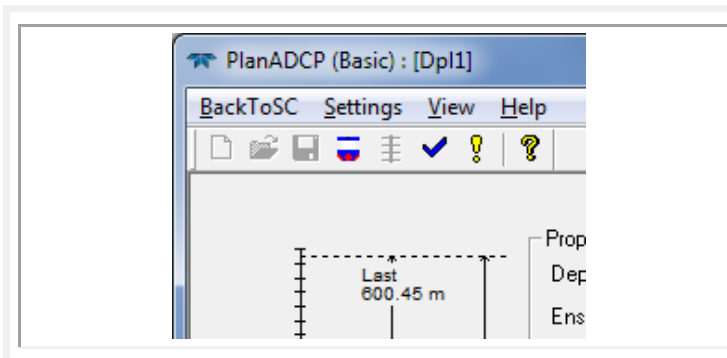

Back to WinSC

Click the **BackToSC** menu to return to *WinSC*.



Long Ranger / QuarterMaster batteries are shipped inside the ADCP but not connected.



At this point, the ADCP should be prepared for deployment, using battery power, and sealed.

Set ADCP's Clock

The next step is to set the ADCP's clock. Press the **N**ext button to set the ADCP's clock to the PC's clock. You should verify that your PC's clock is set correctly before executing this function.

Skip Setting ADCP's Clock

< Back Next > Cancel

The second step will set the Long Ranger / QuarterMaster ADCP's clock to the computer's time and date using the TS-command.

Click **Next** to continue.

Compass Verification

The next step is to verify the ADCP's compass. Press the **N**ext button to begin verifying the compass.

Skip Compass Verification

< Back Next > Cancel

The third step will verify the compass using the AX-command.

 If the internal batteries were replaced, this step will only verify the compass; you must align the compass prior to using the WinSC wizard.

Click **Next** to continue.

Pre-Deployment Tests

The next step is to run pre-deployment tests on the ADCP. Press the **N**ext button to run the tests.

Skip Pre-Deployment Tests

< Back Next > Cancel

The fourth step will run the pre-deployment tests Deploy?, System?, TS?, PS0, PA, PC2, RS, and PC1-commands.

Click **Next** to continue.

Zero Pressure Sensor X

The next step is to zero pressure sensor. Press the **N**ext button to zero pressure sensor.

Skip Zeroing Pressure Sensor

< Back
Next >
Cancel

The fifth step will zero the pressure sensor using the AZ-command. Click **Next** to continue.

Erase Recorder Data X

The next step is to erase recorder data. Uncheck the box and press the **N**ext button to erase recorder data.

Skip Erasing Recorder Data

< Back
Next >
Cancel

The sixth step will erase the recorder using the RE-command. Uncheck the **Skip Erasing Recorder Data** box if you want to erase the data.

 Once erased, the data is not recoverable. Click **Next** to continue.

Deploy the ADCP X

The final step is to deploy the ADCP. Press the **N**ext button to start the deployment.

< Back
Next >
Cancel

The seventh and final step in the Deployment Wizard will send the commands from the command file to the Long Ranger / QuarterMaster. Click **Next** to send the commands.

 **The Long Ranger / QuarterMaster must be powered with the batteries, sealed, and ready to deploy before you click Next.**

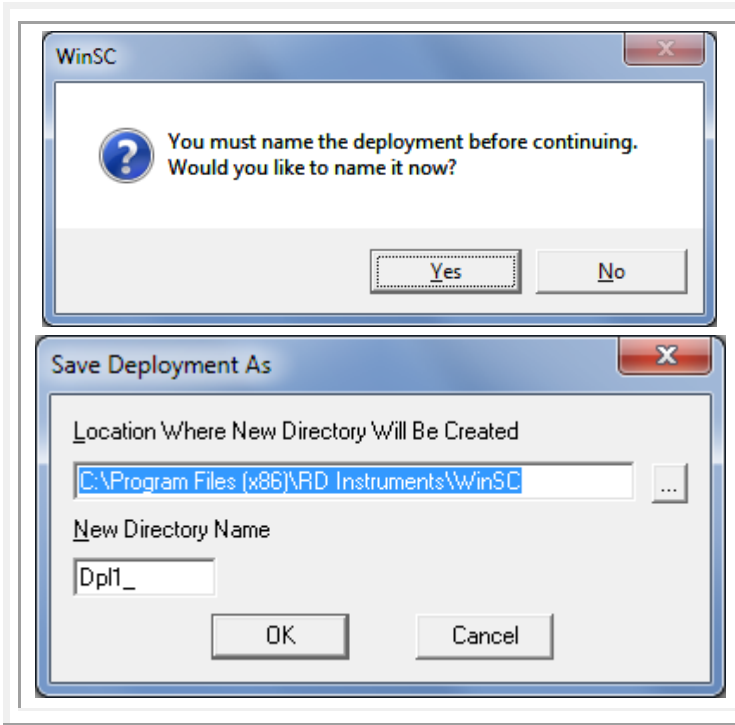

Save Deployment File

If you have not already saved the deployment file, you will be prompted to name the deployment. Choose and use Deployment Names carefully: they help you identify and organize all the data and log files associated with each deployment.

The command file and deployment log file will be saved when the deployment file is saved. For example, if you save the deployment file as *Dpl1_.dpl*, then the command file will be saved as *Dpl1_.whp* and the log file will be saved as *Dpl1_.scl*.

 Before deploying the Long Ranger / QuarterMaster ADCP, scroll through the deployment log file and look for error messages. Correct as needed and re-send the commands.

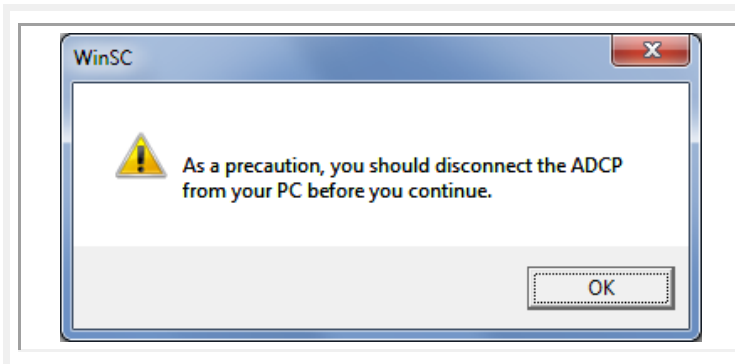

Disconnect the I/O cable and install the dummy plug on the Long Ranger / QuarterMaster ADCP's end-cap.

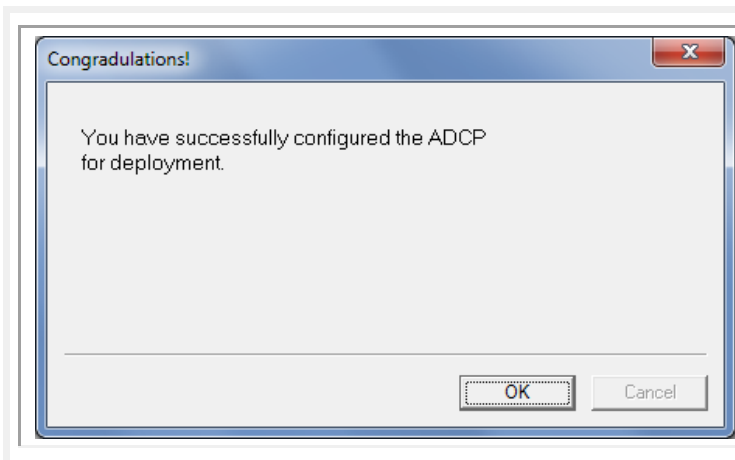

When the commands have been sent to the Long Ranger / QuarterMaster, you should see a message *"You have successfully deployed the ADCP."*

Click **OK**.



Photo courtesy of Paul Devine, Teledyne RD Instruments

Deploy and Recover the system

Once the commands have been sent to the Long Ranger / QuarterMaster, proceed as follows:

Deploy the Long Ranger / QuarterMaster ADCP.



Do not send a break, any other command, or run any other programs once the commands have been sent to the Long Ranger / QuarterMaster ADCP or your commands will be overwritten.

Disconnect the I/O cable before turning off power to the computer. Some computers may send a break signal out the serial ports when shutting down.

Recover Data with WinSC

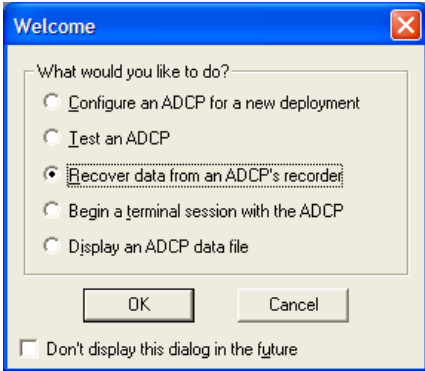

Connect and power up the WorkHorse ADCP.
Start *WinSC*.
At the **Welcome Screen** select **Recover Data from an ADCP's Recorder** or from the **File** menu, select **Recover Recorder Data**.

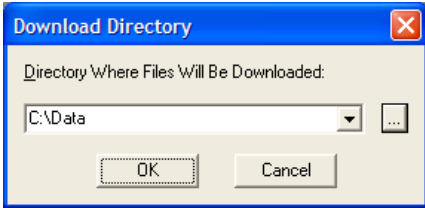

Select the directory where the data will be written.

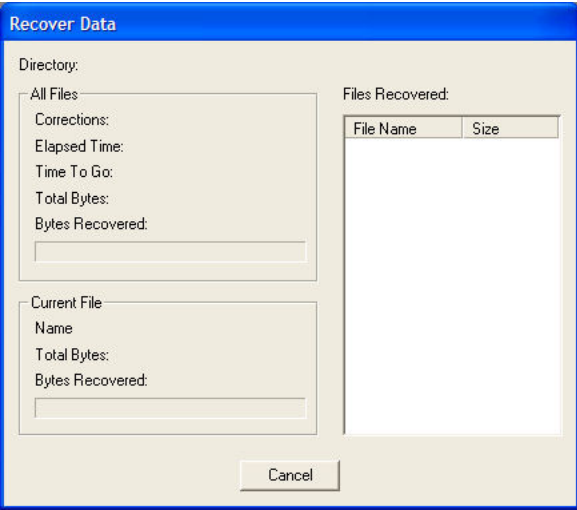

WinSC will increase the baud rate set in the **Com Settings** window to 115200 BAUD to reduce the download time.

Viewing Data with WinSC

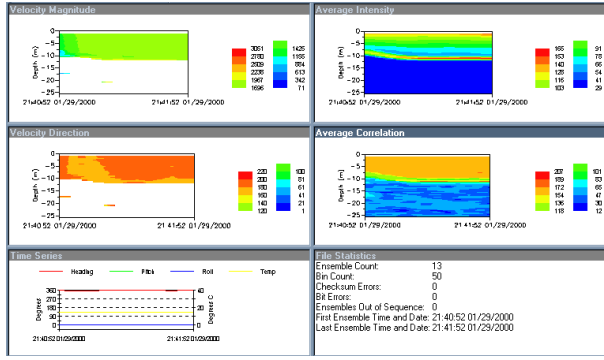

On the **File** menu, click **Open**.

On the **Files of Type** box, select **ADCP Data (*.0*)**.

Select the file and click **Open**.

The data file will display all of the ensembles.

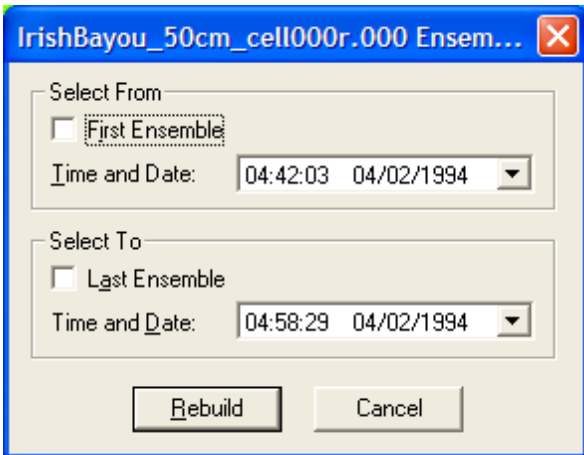

To select a subsection of the data file, use the **View** menu, **Ensemble Selection**.

To quickly select a section, hold the **Control** key while dragging the mouse over the area to be selected.



Display Controls.

Right-click inside any window to bring up the display menu.

To increase the size of a window, click **Maximize Pane** button.

To increase the contrast of the contoured plot, select **Contoured**.

You can increase the contrast between cells and contours by using the **Zone Cells** or **Zone Contours**.

To change the colors of the plot or other plot controls, click **Properties**.

To select the range of a contoured plot, click **Ranges**.

Collecting Real-Time Data

PlanADCP is designed to create a command file that will be used to set up a Long Ranger / QuarterMaster ADCP for collecting data. In this example we will use *PlanADCP* to develop the command file, and *TRDI Toolz* to send the commands to the Long Ranger / QuarterMaster. Then we will use the *WinADCP* program to view the data in real-time.

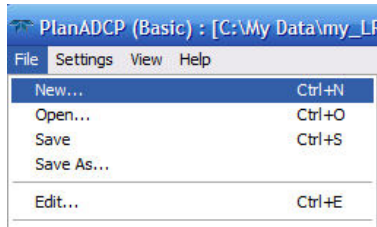

Start *PlanADCP*. On the **File** menu, click **New**.

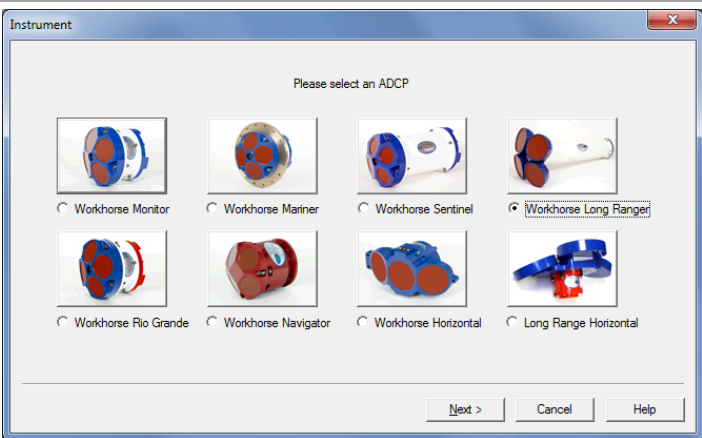

Instrument

Select the type of WorkHorse ADCP you want to create a command file for.

Click **Next** to continue.

 Select **WorkHorse Monitor** (direct reading) or **WorkHorse Sentinel** (self-contained) and set the frequency to 150 kHz for a QuarterMaster ADCP.

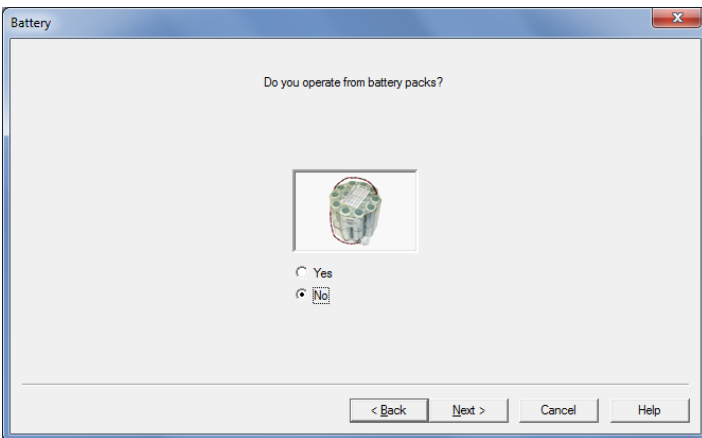

Battery

Select if the WorkHorse has internal batteries. If you select **Yes**, then enter the number of battery packs you are going to use.

Click **Next** to continue.

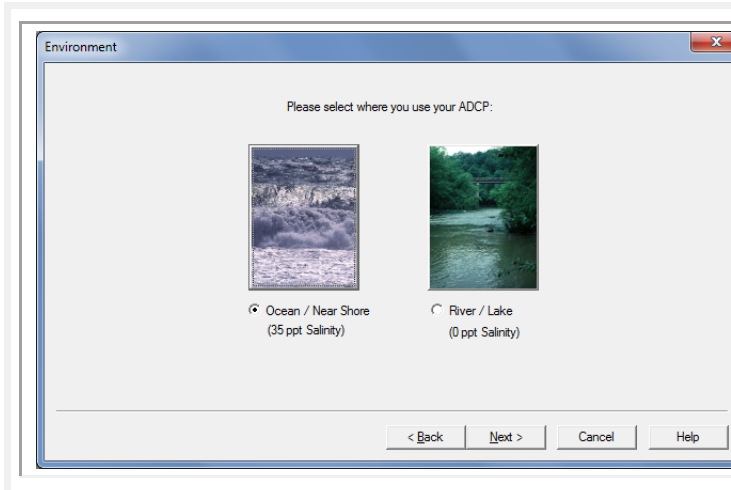

Environment

Select **Ocean/Near Shore** or **River/Lake** to set the salinity. Water salinity affects the maximum range. Salt water is typically 35, fresh water is 0.

Click **Next** to continue.

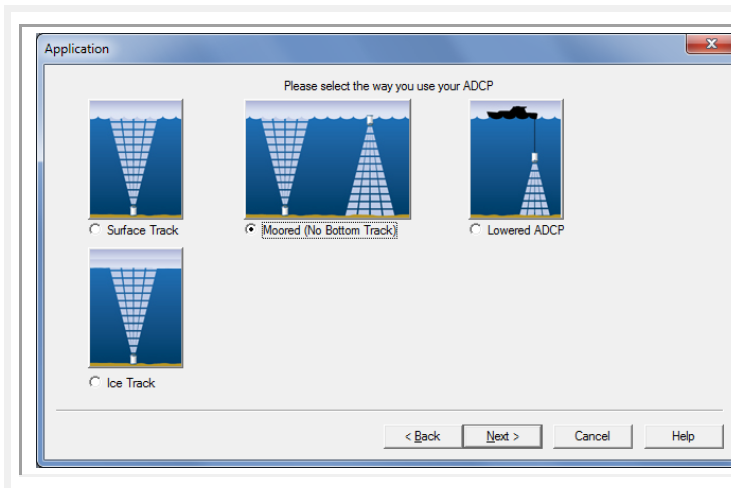

Application

Select **Moored (No Bottom Track)** for the deployment.

Click **Next** to continue.



See the LADCP User's Guide for more info on using Lowered ADCP, surface track and Ice track. See the WorkHorse Command Guide for information on Water Mode 15.

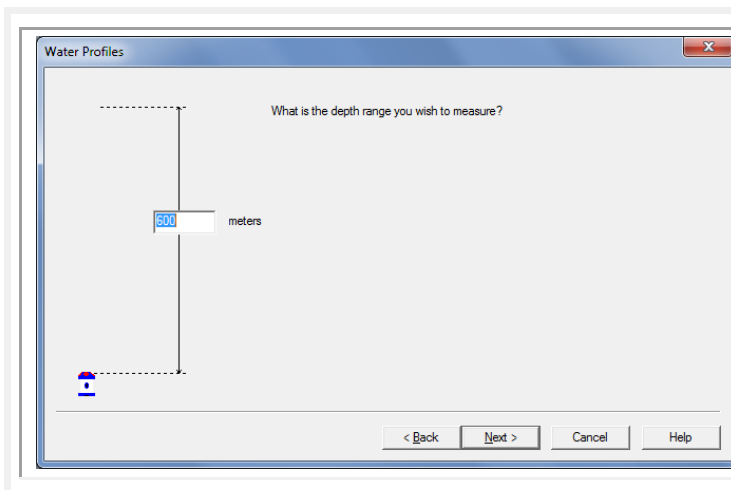

Water Profiles

Select the depth range you wish to measure. The maximum depth range is dependent on the WorkHorse frequency, water salinity, water temperature, and the depth of the WorkHorse.

Click **Next** to continue.

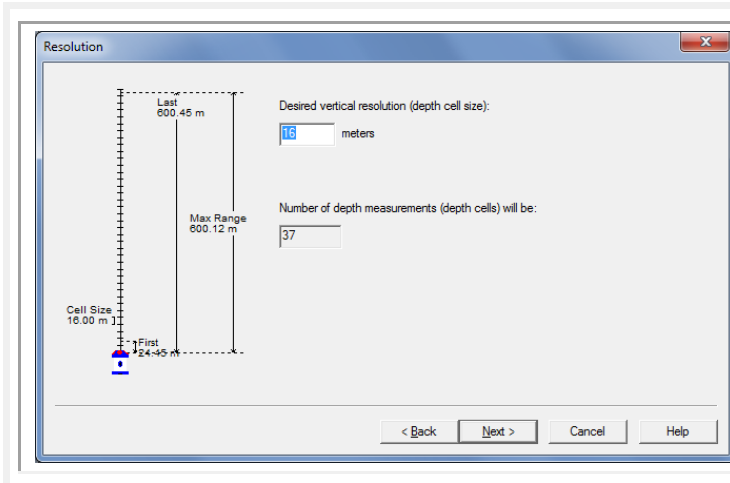

Resolution

Set the depth cell (bin) size. Adjust the depth cell (bin) size as necessary to get at least 10 depth cells (bins). A larger depth cell (bin) size decreases the standard deviation, but shallow water situations may need to use small depth cells (bins) to get more data points.

PlanADCP will set the number of depth cells (bins) so that the consequence *last depth cell (bin) range* is approximately 10% greater than the depth range set in the previous step.

Click **Next** to continue.

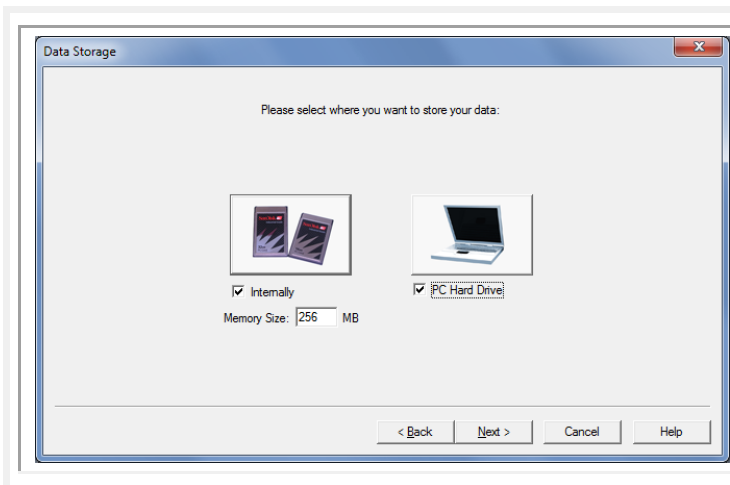

Data Storage

Select where to store the data. Data can be stored internally, sent out the serial port, or both. If you selected **Internally**, enter the amount of memory installed.

Click **Next** to continue.

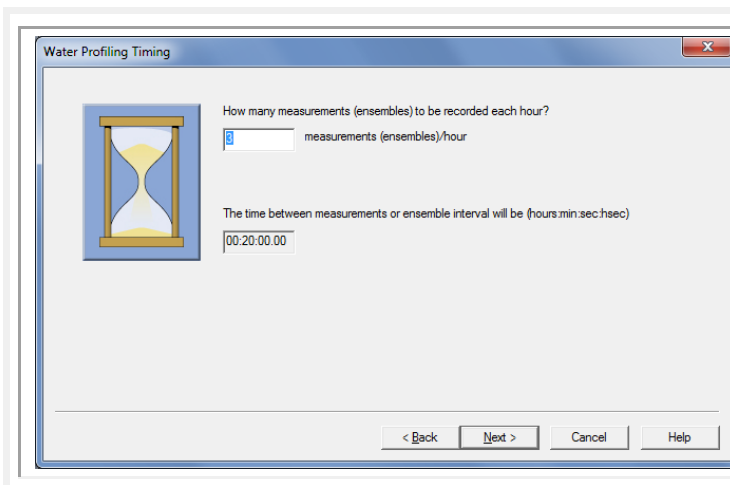

Water Profiling Timing

Select how many ensembles per hour you want to record.

Click **Next** to continue.

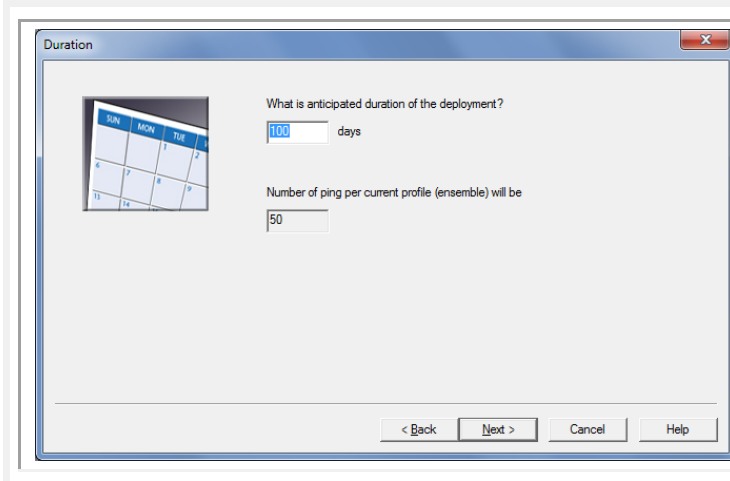

Duration

Enter the expected duration of the WorkHorse deployment from the time of the first water profiling ping (either immediately or first ping date/time). This duration *does not* produce a command to instruct the WorkHorse to stop data collection; it is for estimating consequences only. This duration is used to estimate the following *consequences*:

- Power requirements
- Ensembles
- Storage required

Click **Next** to continue.

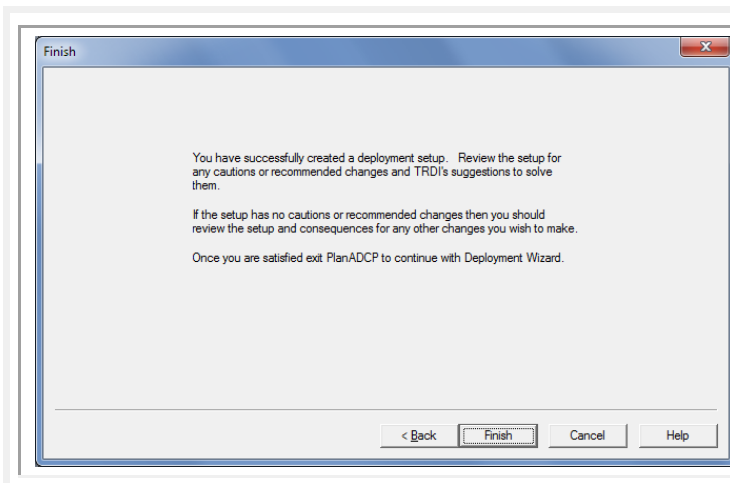

The wizard is now finished.
Click **Finish**.

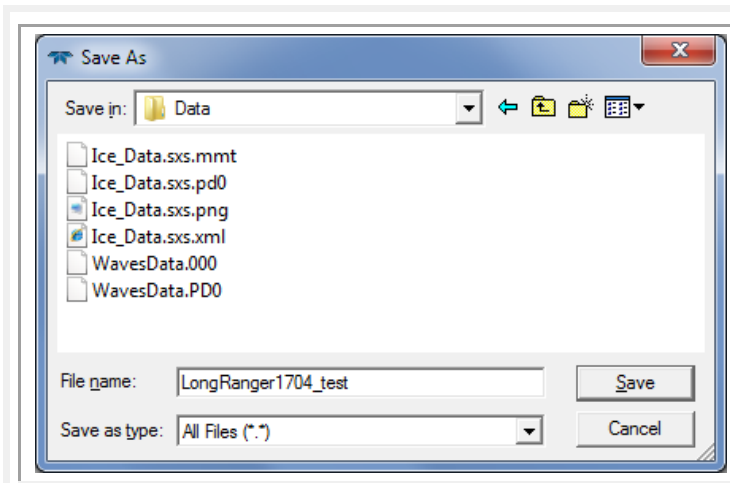

Save the Command File

On the **File** menu, click **Save**. Name the command file and click **Save**.

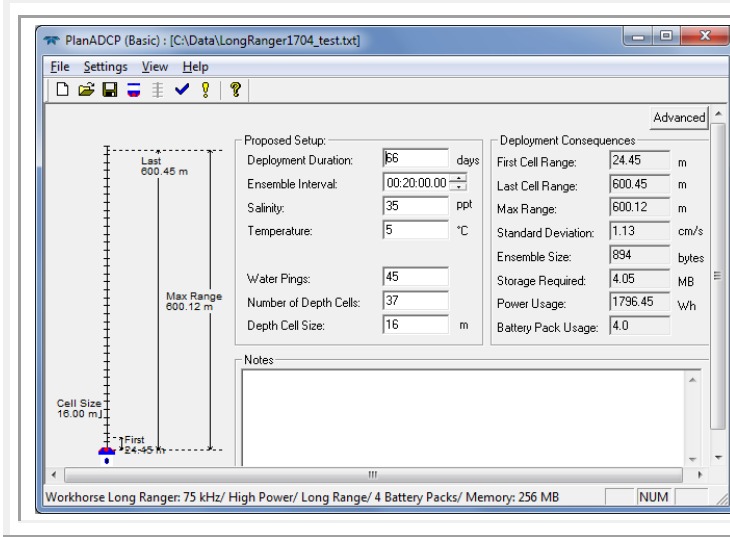

The *PlanADCP* (Basic) Screen opens using the settings you selected with the wizard. Review the consequences (see the WinSC and PlanADCP User's Guide for details).

On the *PlanADCP* (Basic) Screen click the **Advanced** button to bring up the **Advanced** setting screen.



The 6000 meter extended range QuarterMaster is not supported by PlanADCP. To estimate the power consumption of the extended range QuarterMaster, plan for a standard WorkHorse 150 kHz and multiply the energy consumed by 1.5 to 1.75.

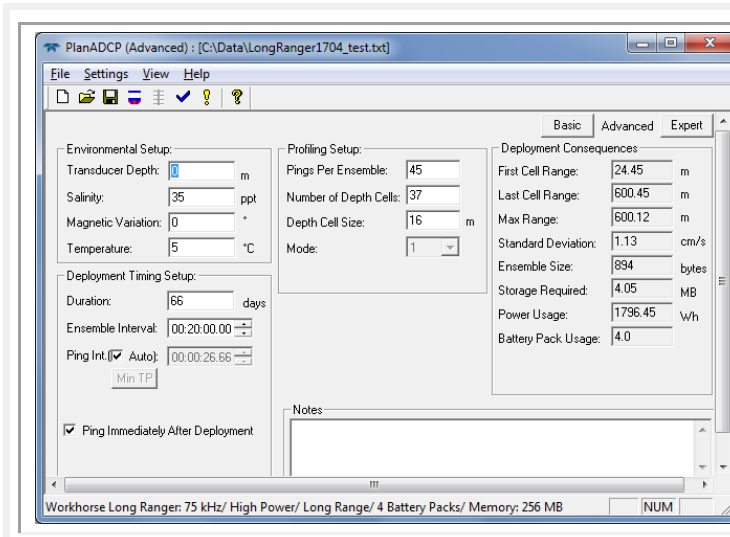

Advanced Screen

Uncheck the **Ping Immediately After Deployment** box and enter a date and time you want the WorkHorse ADCP to begin pinging.

Start sample intervals on the minute by using a delayed start up. Instead of having your 10-minute sample intervals start at 12:36:47, delay startup a few minutes to have samples start at 13:00:00.

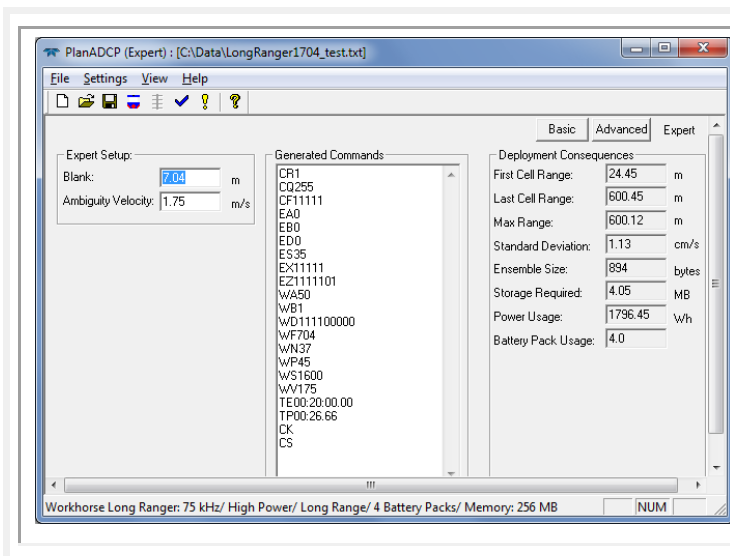

Setup Advanced Screen

On the *PlanADCP* (Advanced) Screen click the **Expert** button to bring up the **Expert** setting screen.

You can view the commands that will be sent to the WorkHorse.

Exit PlanADCP.



For 75 kHz Long Ranger systems, set the Power setting (CQ command) and bandwidth (WB command) in *PlanADCP* through the hardware selection page. See the WinSC and PlanADCP User's Guide for details. The Power setting is used on the 75 kHz Long Ranger only. Although the QuarterMaster ADCP allows the CQ command to be set to values other than the default, the CQ command has no effect and is not supported by *PlanADCP*.

Sending the Commands to the ADCP

To send multiple commands to configure the ADCP and start it pinging, use *TRDI Toolz* or *BBTalk*.

Sending the Commands using TRDI Toolz

<pre>[BREAK Wakeup A] WorkHorse ADCP 43.xx Teledyne RD Instruments (c) 1996-2013 All Rights Reserved. ></pre>	<p>Setup the communication parameters between <i>TRDI Toolz</i> and the ADCP.</p> <p>Wake up the ADCP by pressing the  button.</p>
--	---

	<p>On the Tools menu, select Script Editor.</p> <p>Click the Open icon and select the file to run from the scroll-down list. If no extension is given for the script file, an extension of *.txt is assumed.</p>
---	---

	<p>Click the Send icon. Clicking the drop-down menu will show the options to Send to current or Send to all. Use the Send to all feature to send the same script file to all connected ADCPs.</p> <p>Click the Log to File icon  to save the data to your computer.</p>
---	---

	<p>Use the Layout menu to show or hide the Ensemble Display and Terminal windows. The Ensemble Display shows limited situational data (Ensemble Time, Temperature, Heading, Pitch, Roll, Bottom track range/velocity, Vertical Beam range) in tabular form from the ADCP data stream, when present.</p>
---	---

Sending the Commands using BBTalk

<pre>[BREAK Wakeup A] WorkHorse ADCP 43.xx Teledyne RD Instruments (c) 1996-2013 All Rights Reserved. ></pre>	<p><u>Wakeup the WorkHorse</u></p> <p>Start <i>BBTalk</i>. On the File menu, click Break (you can also press the End key to send a break or and press the B button on the Toolbar).</p> <p>You should see the wakeup message appear on the log file window.</p>
--	--

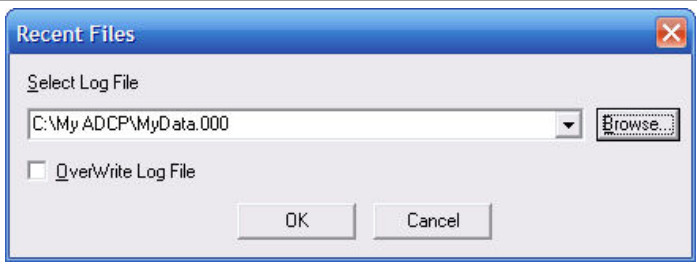
	<p><u>Create a Log File</u></p> <p>Press F3 and create a log file. Name the file and use *.000 for the file extension.</p>
---	--

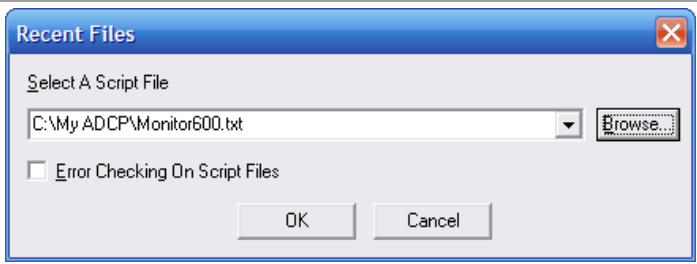
	<p><u>Send the Commands to the WorkHorse</u></p> <p>Press F2 and use the Browse button to locate the command file.</p> <p>You should see the commands appear on the log file window and the WorkHorse ADCP's response.</p> <p>Carefully review the log file window and make sure that no command created an error message.</p>
---	---

Viewing Data in Real-Time

WinADCP has the ability to automatically update the reading of a file as real-time data collection is occurring. When the file size increases, (due to real-time data collection) **Monitor** will automatically reread the file at selected intervals and display the contents. When **Monitor** is enabled and the file size is changing, all menu items except **Monitor** will be unavailable.

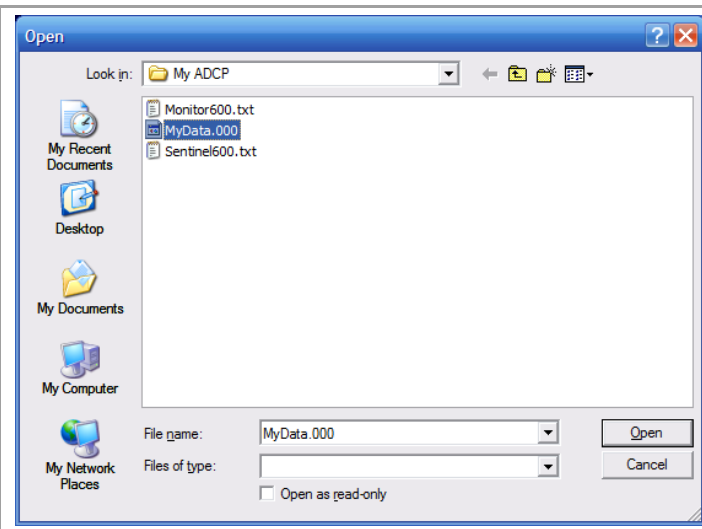

Start WinADCP

Start WinADCP.

On the **File** menu, click **Open**.

Select the log file created with *TRDI Toolz* (see [Sending the Commands to the ADCP](#)).

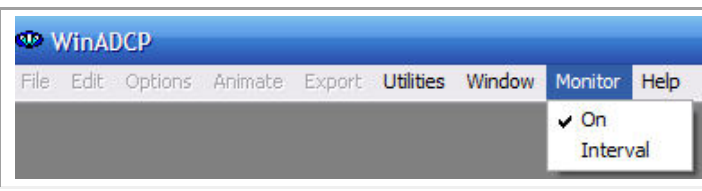

On the **Monitor** menu, select **ON**.

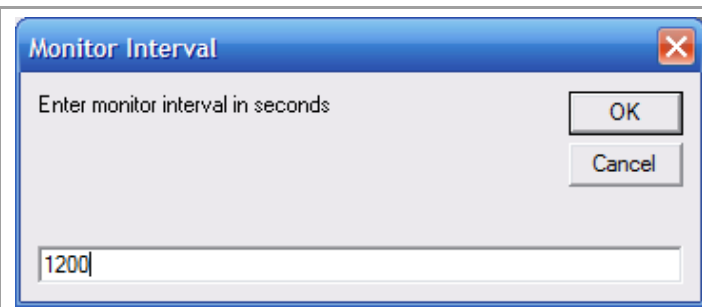

You can change the interval by clicking **Monitor, Interval**.

Enter the monitor interval in seconds. For example, a 20 minute ensemble would be 1200 seconds.

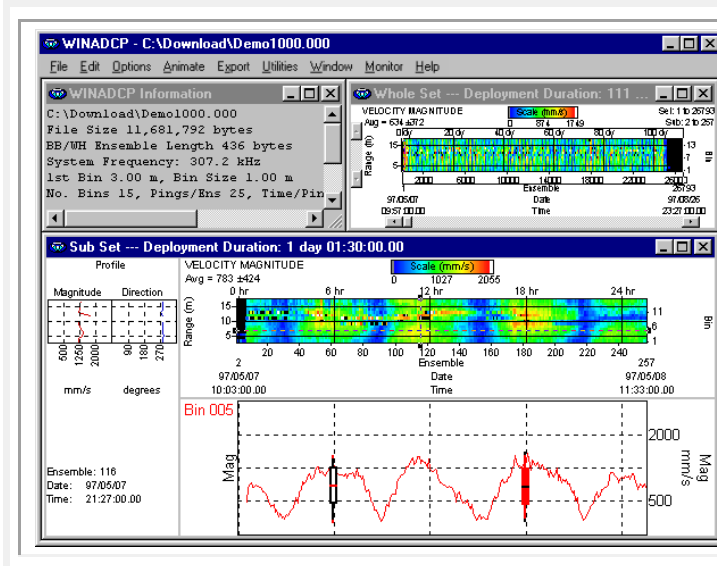

WinADCP has two main graphic display forms. The form located in the upper right portion of the screen is called the **Whole Set**. The form located across the bottom half of the display is called the **Sub Set**. Each of these forms displays a portion of the entire data set as a color contour. In addition to the color contour, **Sub Set** displays the user selected **Profile**, **Series**, and **Ancillary** data.

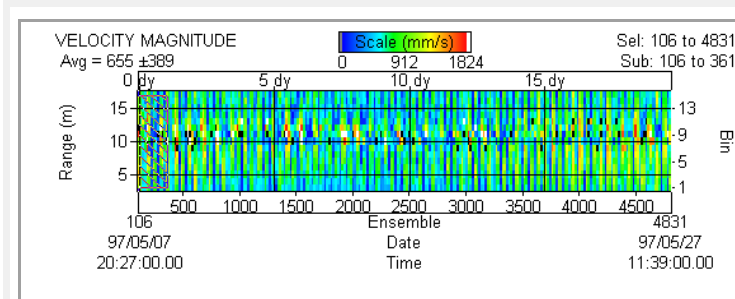

The **Whole Set** form is displayed in the upper right-hand portion of *WinADCP*. When a file containing a Binary Output Data Format is opened, the entire set of the selected data type is displayed as a color contour located within the **Whole Set** form.

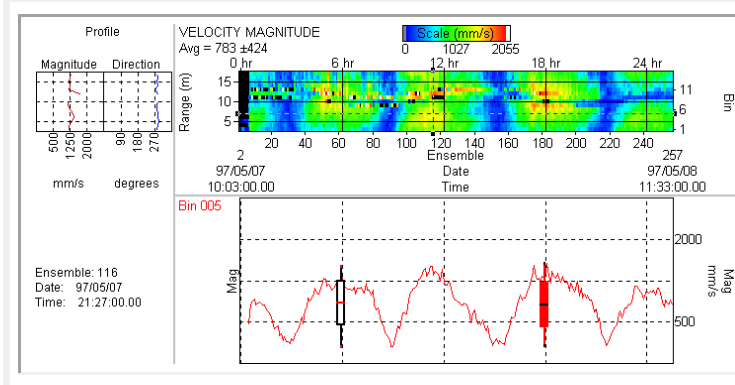

By holding down the **Spacebar** and then pressing the **Left** mouse button, the user can drag the mouse to select a portion of the entire data set. When the mouse button is released, the selected portion of the **Whole Set** is marked by a blinking box outline. The blinking box outlines a set of data called the **Selected Set**.

Chapter 4

MAINTENANCE



In this chapter, you will learn:

- Where parts are located on the ADCP
- How to spot problems
- How to take the ADCP apart and put it back together
- How to replace the batteries
- How to do periodic maintenance items on the ADCP

Parts Location Drawings

This section is a visual overview of the inside and outside parts of the Long Ranger / QuarterMaster ADCP. Use the following figures to identify the parts used on your system.

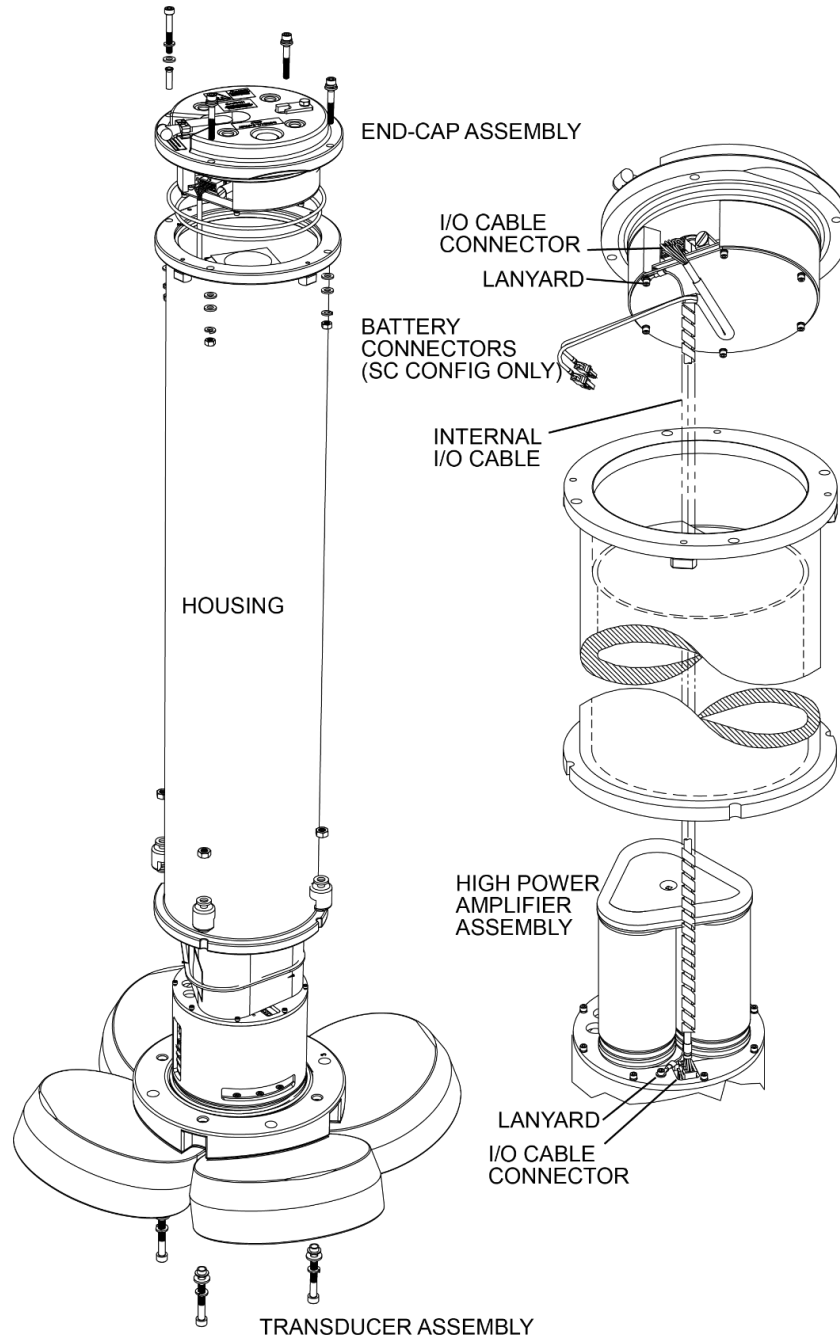

Figure 26. Long Ranger / QuarterMaster Housing Removal



Weight in air for a LongRanger/QuarterMaster system is between 38.5 Kg (85 pounds) to 124.7 Kg (275 pounds). Use lifting aids and proper lifting techniques when moving.

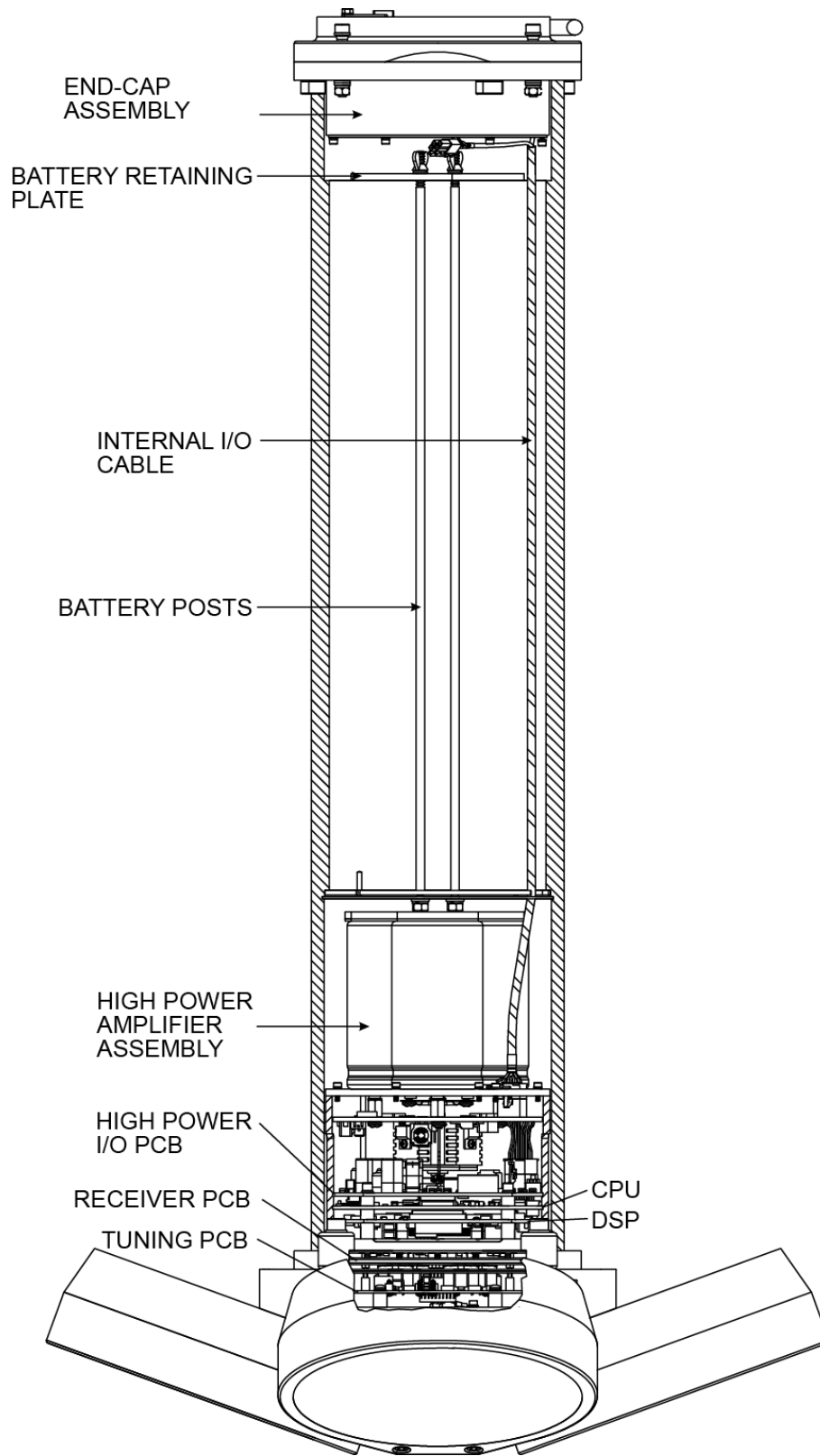

Figure 27. Long Ranger / QuarterMaster Part Locations

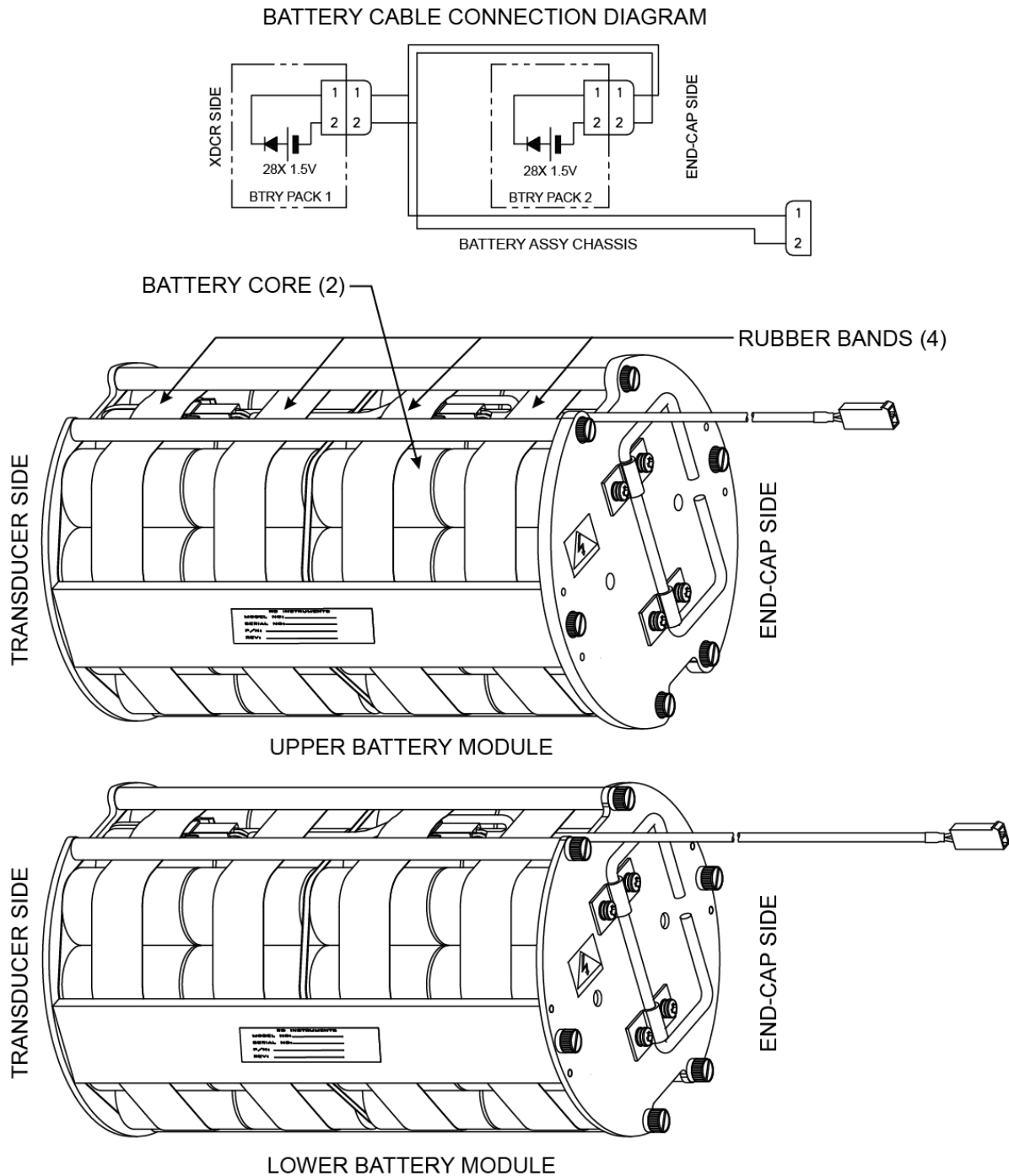

Figure 28. Long Ranger / QuarterMaster Battery Modules



The upper battery pack module has a thicker and larger diameter topplate as well as a shorter battery pack power cable. This module will not slide down as far into the housing as the bottom module.

The Self-Contained two battery configuration only uses the upper battery pack module.

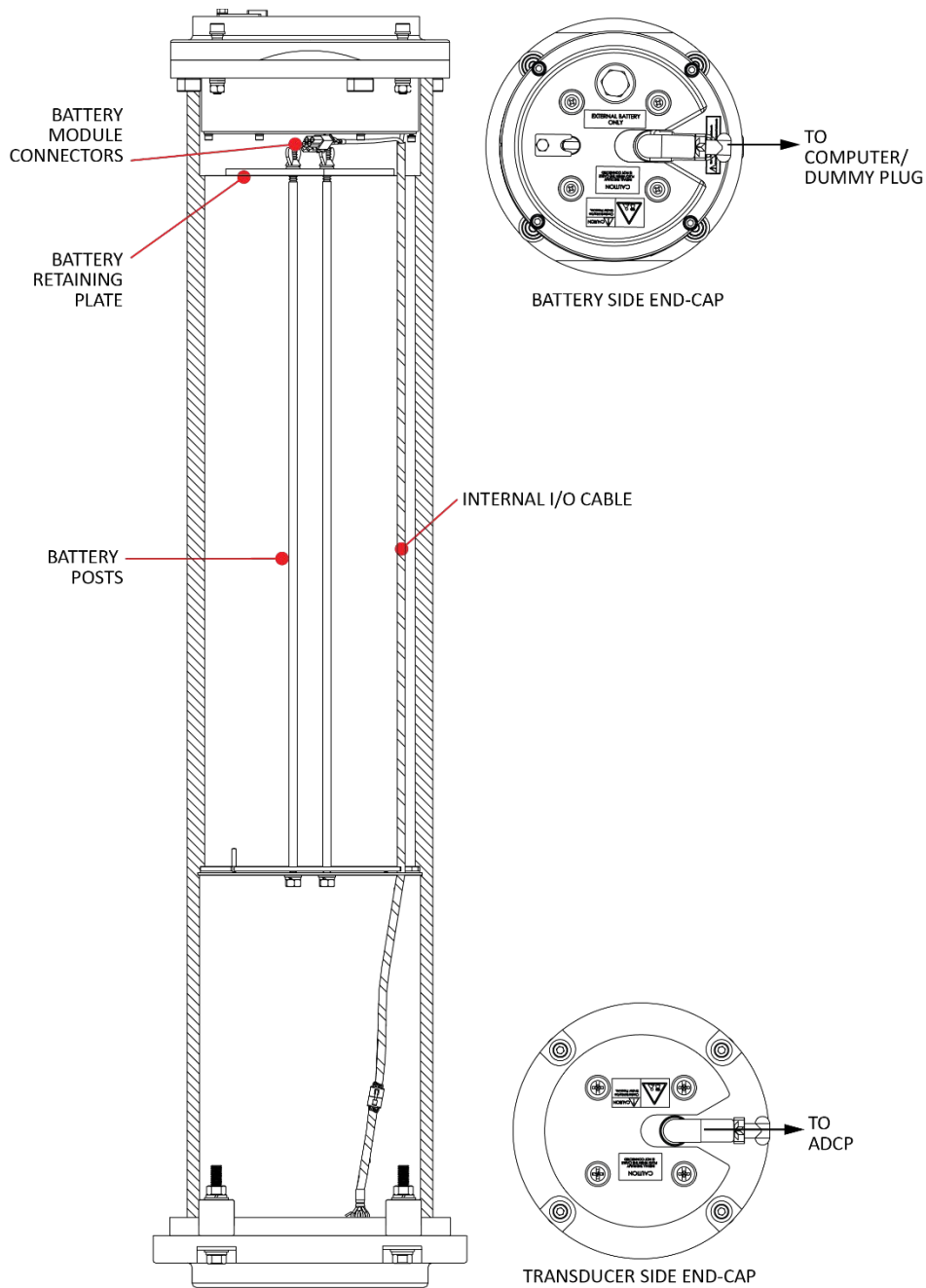

Figure 29. External Battery Case



Do not swap end-caps between the external battery case and the standard Long Ranger / QuarterMaster end-cap.



The external battery case, battery side end-cap is different than the standard Long Ranger / QuarterMaster end-cap. Figure 49 shows the standard Long Ranger / QuarterMaster end-cap. The common mode choke coil is very visible behind the internal I/O cable connector and fuse. The common mode choke coil is NOT installed on the battery side end-cap.

Maintenance Schedule

To ensure that you continue to receive optimal results from your Teledyne RD Instruments product(s), TRDI recommends that every ADCP be returned to our factory for an inspection every two to three years. We'll provide your unit with a thorough multi-point inspection, and let you know if any refurbishment services are required to properly maintain the unit. To learn more about this service, please [contact field service](#).

Calibration Items

Use the following calibration schedule:

Item	TRDI Recommended Period
Transducer Beam Angle Pitch & Roll (Tilt)	TRDI recommends return every two to three years for verification of velocity accuracy
Temperature (Factory) Pressure Sensor (Factory) Heading (Factory)	TRDI recommends return every two to three years for Factory calibration
Heading (Field Pre-Deploy)	Field Compass Calibration (AF) performed prior to each deployment (see Compass Calibration)
Heading (Field Post-Deploy)	Field Compass Verification (AX) performed post each deployment (see Compass Calibration Verification)



Pressure sensor and compass drift effects will accumulate over time. TRDI recommends a factory calibration be done every two to three years. The longer you wait between factory calibrations, the more error (due to drift) you can expect to have.

For example, the pressure sensor has an initial accuracy spec of $\pm 0.25\%$, and a long-term drift spec of $\pm 0.11\%$. Most of the 0.11% drift will occur in the first 12 months of operation. The fluxgate compasses accumulate an error of approximately 1% over a year.

Maintenance Items

Inspect the ADCP to spot problems:

Item	TRDI Recommended Period
Transducer Beams	<p>The urethane coating is important to ADCP watertight integrity. Many users are not familiar with the early signs of urethane failure. The primary damage to the urethane is from bio-fouling and long exposure to the water and sun. Damage occurs on the surface of the urethane and at the edge where the urethane bonds to the cups. Mishandling, chemicals, abrasive cleaners and excessive depth pressures can also damage the transducer ceramics or urethane coating.</p> <p>Before each deployment, check the urethane coating on the transducer faces for dents, chipping, peeling, urethane shrinkage, hairline cracks and damage that may affect watertight integrity or transducer operation (see Figure 30).</p> <p>Based on experience, TRDI knows that most systems need to have the urethane inspected after three to five years of field use; shorter periods may be required depending on marine growth.</p>

Item	TRDI Recommended Period
O-rings	<p>O-rings should be replaced whenever the system is opened and BEFORE they are showing any signs of wear and tear. For example, when replacing the Long Ranger / QuarterMaster battery, the end-cap is removed. Replace the end-cap O-ring each time the end-cap is removed.</p> <p>All O-rings should be replaced every one to two years maximum.</p>
Housing and End Cap	<p>Inspect for damage and replace as needed before each deployment.</p> <p>Inspect the paint on the end-cap, housing, and transducer assemblies for corrosion, scratches, cracks, abrasions, paint blisters, exposed metal (silver-colored aluminum), exposed anodize (black or dark green), and exposed primer (yellow). Be critical in your judgment; the useful life of the Long Ranger / QuarterMaster depends on it. See Protective Coating Inspection and Repair for details.</p>
Hardware (bolts, etc.)	<p>Check all bolts, washers and split washers for signs of corrosion before each deployment.</p> <p>TRDI recommends replacement after every deployment or every year whichever is longer. Damaged hardware should never be used.</p>
Zinc Anodes	<p>Inspect the anodes (available on aluminum systems only) before each deployment for wear around the mounting bolts. Cover bolts with silicone sealant prior to deployment. Replace anodes whenever the mounting bolt is in less than 75% in contact with the bolt. Replace all anodes every one to two years maximum.</p>
Purge Plug	<p>The purge plug is a safety valve and is designed to push out of the system to ensure that there is not excessive pressure inside the system when removing the end cap. Replace the plug O-Rings every 2-3 years.</p>
Cables and Connectors	<p>Check the end-cap I/O connector for cracks or bent pins (see Figure 31) before each deployment.</p> <p>Replace the end-cap I/O connector every five years as a normal maintenance item (see Table 2. Replacement Kits to order parts).</p> <p>Check the cable connectors for cracks or bent pins. Inspect the full length of the cable for cuts, nicks in the insulation, and exposed conductors before each deployment.</p>
CPU Lithium Coin-Cell Battery	<p>TRDI recommends replacing the lithium coin-cell battery every five years.</p>

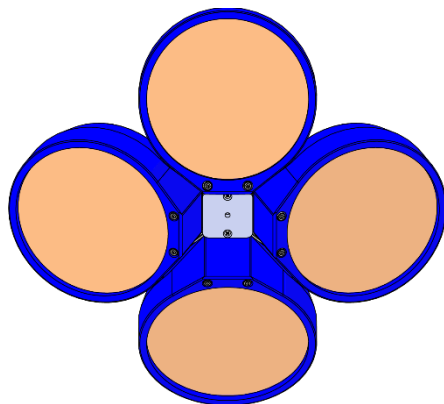

Figure 30. Transducer View

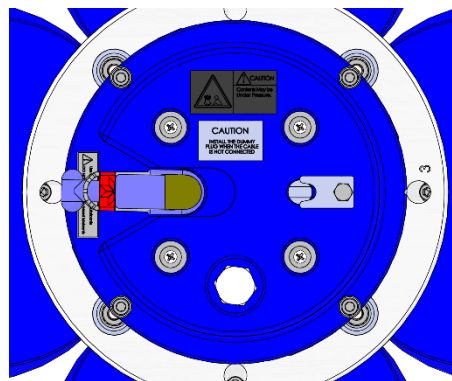

Figure 31. End-Cap View

Spare Parts

Use the following table if you need to order replacement parts.

Table 1: Long Ranger / QuarterMaster Spare Parts

Part Number	Item Name	Where Used
97Z-6050-00	O-ring, 2-258, DURO 70, EPDM (bore O-ring, 1500 and 3000 meter housings)	
97Z-6052-00	O-ring, 2-260, DURO 70, EPDM, (face O-ring standard 1500 meter housing)	
97Z-6053-00	O-ring, 2-261, DURO 70, EPDM, (face O-ring 3000 and 6000 meter housing)	
97Z-6051-00	O-ring, 2-259, (bore O-ring 6000 meter housing)	O-Rings/Housing
8-258 N300-90	Backup O-ring, 8-258 N300-90 (3000 meter housing)	
5288T312	Backup O-ring, size 259, 90 DURO, BUNA-N Type (6000 meter housing)	
5020	Silicone Lubricant, 4-Pack	
810-4005-00	Anode, SC/DR Housing Flange	
M5X0.8X16BHS	Screw, Button/Socket Head SST	
810-4006-00	Anode, Housing Flange, 3000/6000M	Anodes
M4X0.7X14FH	Screw, Flat Head, SST	
817-1086-00	Anode, Square Transducer	
M4X0.7X16FH	Screw, FHD, Phillips SST	
305D0010	Bushing, Housing	
810-4004-00	L Bushing, Housing	
M5WASHSPL	Washer, Split Lock, SST	
M6WASHNYLON	Washer, FLAT, 6.4 ID 12.5 OD, NYLON	
M6WASHSPL	Washer, Split Lock SST316	
M6WASHSTD	Washer, FLAT, 12.5MMOD SST 316	
M6WINGNUT	Nut, Wing, SST	Housing
M6X1.0NUT	Nut, Hex, SST 316	
M6X1.0X45SH	Screw, SKT HD, SST316 (1500 meter end-cap)	
M6X1.0X80SH	Screw, SKT HD, SST316 (3000/6000 meter end-cap)	
M8WASHSPL	Washer, Split Lock, SST316	
M8WASHSTD	Washer, Flat, 16MM OD, SST316	
M8X1.25NUT	Nut, Hex, SST316	
M8X1.25X45SH	Screw, SKT HD, SST 316	
GMA-4A	Fuse, 4A, 250 V, Fast Blow	Main Electronics
22205	Threadlocker, Capsule, .05 oz.	
DES3	Desiccant, Sealed Bag	Inside Housing

Table 2. Replacement Kits

Part Number	Description	Where Used
757K6122-00	End-Cap Tools Kit	Replacing the End Cap Connector
757K6129-00	End Cap Connector Replacement Kit (requires the End-Cap Tools Kit)	
757K6051-00	Battery Pack Kit (includes 1 battery, desiccant, and 2 rubber bands)	Replacing the Battery Packs
TLP-83131/I/BE1A	Battery Pack, Lithium, 1500 Watt Hours, WH	Replacing the External Battery Case Packs
757K6128-00	Anode Kit, 1500 Meter Long Ranger / QuarterMaster	Zinc Anode Inspection and Replacement
757K6035-06	Long Ranger 75 kHz Spare Boards Kit	
757K6035-07	QuarterMaster 150 kHz Spare Boards Kit	Installing the Spare Boards Kit
757K6044-00	Tools and Spare Parts Kit, 1500 meter	
757K6044-01	Tools and Spare Parts Kit, Long Ranger, 3000 meter	
757K6044-02	Tools and Spare Parts Kit, QuarterMaster, 6000 meter	
757K6044-03	Tools and Spare Parts Kit, Long Ranger, 3000 meter, Titanium Hardware	Replacement spare parts kits
757K6044-04	Tools and Spare Parts Kit, QuarterMaster, 6000 meter, Titanium Hardware	
757K6044-06	Tools and Spare Parts Kit, 1500 meter, Titanium Hardware	
727K6093-00	Close-up Kit, Long Ranger / QuarterMaster, 3000 meter	
727K6093-02	Close-up Kit, QuarterMaster, 6000 meter	
727K6093-03	Close-up Kit, QuarterMaster, 6000 meter, Titanium Hardware	Includes all O-rings, hardware, and bushings needed to seal the ADCP
727K6093-04	Close-up Kit, Long Ranger / QuarterMaster, 3000 meter, Titanium Hardware	

Disassembly and Assembly Procedures

This section explains how to remove and replace the end-cap or housing to gain access to the ADCP's electronics, batteries, and internal recorder. Read all instructions before doing the required actions.

- [Removing the End-Cap](#)
- [Removing the Battery Pack Modules](#)
- [Housing Assembly Removal](#)
- [O-ring Inspection and Replacement](#)
- [Replacing the Housing Assembly](#)
- [Replacing the Battery Pack Modules](#)
- [Replacing the End-Cap](#)

Removing the End-Cap



Caution label on End-Cap



Wear safety glasses and keep head and body clear of the end-cap while opening.
Any system that was deployed may have pressure inside the housing.

To remove the end-cap:

1. Dry the outside of the ADCP.
2. Disconnect the I/O cable and install the dummy plug.
3. Stand the ADCP on its transducer faces on a soft pad.
4. Inspect the housing and end cap bolts for any signs of damage such as bending, stretched bolts, crushed or deformed bushings, etc. These signs may indicate that there is internal pressure inside the system (see to Figure 35, page 72).
5. To avoid any possible injury it is ALWAYS recommended to vent the system:

If the system includes a Vent Plug, use the Vent Plug to vent the system before opening the housing. Loosen the port $\frac{1}{2}$ turn and listen for airflow; if none, then open another $\frac{1}{2}$ turn and listen again for airflow. Repeat until the Vent Plug is fully removed. This will ensure no internal pressure is present when removing the housing.

If the system does not have a Vent Plug, loosen but do not remove the four transducer bolts to allow any internal pressure to be vented from the system. **Loosen the transducer bolts two turns each. Repeat until the face seal O-ring is not compressed and the system has the opportunity to vent.** If you note that the end-cap moves as you loosen the bolts then this may indicate that internal pressure is present. Be sure to only loosen the bolts far enough to allow the system to vent.

6. Once all four end-cap bolts have been loosened and you are sure that there is no internal pressure, remove the bolts from the end-cap.



Make sure you save all hardware removed during this procedure for re-assembly.

7. Carefully pull the end-cap away from the housing until you can gain access to the connector jack on the common mode choke. Use care; the plastic mating surfaces scratch easily. Do not damage the mating surfaces.



A lanyard prevents the end-cap from being pulled too far away from the housing to prevent damage to the internal I/O cable. Place a cloth between the end-cap and housing to protect the paint; the lanyard will hold the end-cap. Once the internal I/O cable is disconnected, remove the screw holding the lanyard in place.

8. Squeeze the sides of the internal I/O cable connector to release it from the common mode choke jack. Set the end-cap aside.
9. When recovering the Long Ranger / QuarterMaster from a deployment, remove any water from the end-cap O-ring grooves. Clean the O-ring mating surfaces with a soft, lint-free cloth. Inspect the surfaces for damage (see [O-ring Inspection and Replacement](#)). Even small scratches can cause leakage around the O-ring seal.

Removing the Battery Pack Modules

To remove the battery pack modules:

1. Remove all power to the Long Ranger / QuarterMaster.
2. Remove the I/O cable and place the dummy plug on the I/O cable connector (see [I/O Cable and Dummy Plug](#)).
3. Remove the end-cap (see [End-Cap Removal Procedures](#)).
4. Disconnect the two battery power cables from the internal I/O cable (see [Parts Location Drawings](#)).
5. Remove the wing nuts, lock washers, and washers holding the battery pack modules onto the posts.
6. Slide out the battery pack modules.

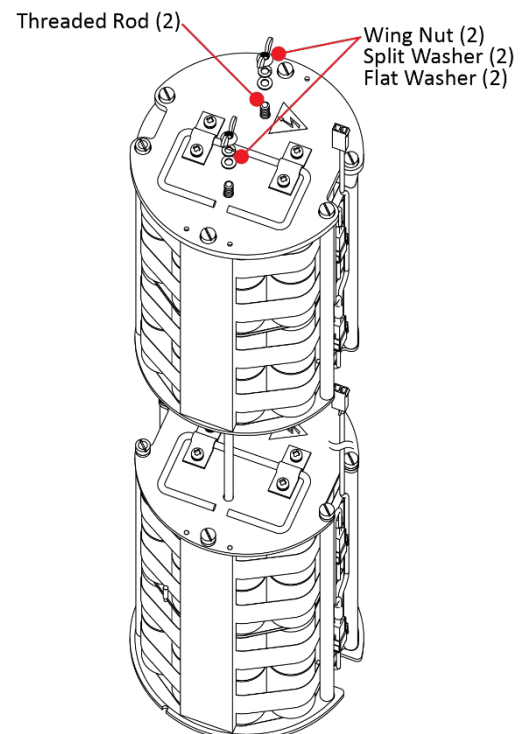

Removing the Housing Assembly

To remove the housing:

1. Remove all power to the Long Ranger / QuarterMaster.
2. Remove the I/O cable and place the dummy plug on the I/O cable connector (see [I/O Cable and Dummy Plug](#)).
3. Remove the end-cap (see [End-Cap Removal Procedures](#)) and battery modules (see [Battery Pack Module Removal](#)).
4. Stand the Long Ranger / QuarterMaster on its transducer faces on a soft pad.
5. Loosen and remove the four bolts (8-mm) that attach the housing flange to the transducer head assembly.
6. Carefully lift the housing assembly straight up and away from the transducer until you can gain access to the connector jack on the electronic chassis high power I/O board (see [Parts Location Drawings](#)). Do not damage the mating surfaces of the housing or transducer.
7. Squeeze the sides of the internal I/O cable connector to release it from the jack. Set the housing assembly aside.



A lanyard prevents the housing from being pulled too far away from the transducer to prevent damage to the I/O cable. Once the I/O cable is disconnected, remove the screw holding the lanyard in place.

8. Clean the O-ring mating surfaces with a soft, lint-free cloth. Inspect the surfaces for damage.
9. When you are ready to re-assemble the Long Ranger / QuarterMaster, see [Long Ranger / QuarterMaster Re-assembly](#).

O-ring Inspection and Replacement

This section explains how to inspect/replace the Long Ranger / QuarterMaster O-rings. A successful deployment depends on the condition of four O-rings and their retaining grooves. Read all instructions *before* doing the required actions.

- Transducer and end-cap assembly, face, 2-260
- Transducer and end-cap assembly, bore, 2-258

Systems with a 97Z-4000-00 Vent Plug

- 97Z-6084-00 O-RING, 2-015, .070DIAX .551 ID, EPDM, DURO90A, VENT PLUG
- 97Z-6084-01 O-RING, 3-094, .072DIAX .351 ID, EPDM, DURO90A, VENT PLUG



The above listed O-rings are valid for the standard 1500 meter housing only. If you are using the 3000 meter housing, see [High Pressure O-rings](#).

TRDI strongly recommends replacing these O-rings whenever you disassemble the Long Ranger / QuarterMaster. Inspecting and replacing the O-rings should be the last maintenance task done before sealing the Long Ranger / QuarterMaster.



TRDI recommends you use new O-rings if you are preparing for a deployment.

To replace the O-Ring:

1. Inspect the O-rings. When viewed with an unaided eye, the O-rings must be free of cuts, indentations, abrasions, foreign matter, and flow marks. The O-ring must be smooth and uniform in appearance. Defects must be less than 0.1 mm (0.004 in.).



If the O-ring appears compressed from prior use, replace it. Weak or damaged O-rings will cause the ADCP to flood.

2. Clean and inspect the O-ring grooves. Be sure the grooves are free of foreign matter, scratches, indentations, corrosion, and pitting. Run your fingernail across damaged areas. If you cannot feel the defect, the damage may be minor; otherwise, the damage may need repair.



Check the O-ring groove thoroughly. Any foreign matter in the O-ring groove will cause the ADCP to flood.

3. Lubricate the O-ring with a thin coat of silicone lubricant (Table 1, item 5). Apply the lubricant using latex gloves. Do not let loose fibers or lint stick to the O-ring. Fibers can provide a leakage path.



Apply a very thin coat of silicone lube on the O-ring. Using too much silicone lube on the O-ring can be more harmful than using no O-ring lube at all.

High Pressure O-rings

The instructions for inspection and replacement of the Long Ranger / QuarterMaster 3000-meter O-rings are the same as for the standard Long Ranger / QuarterMaster *with the exception of different O-ring sizes and the addition of a backup O-ring*. Use the following part numbers and Figure 32.

- Transducer and end-cap assembly, face 2-261
- Transducer and end-cap assembly, bore 2-258
- Transducer assembly, backup O-ring, 8-258 N300-90

Systems with a 97Z-4000-00 Vent Plug

- 97Z-6084-00 O-RING, 2-015, .070DIAX .551 ID, EPDM, DURO90A, VENT PLUG
- 97Z-6084-01 O-RING, 3-094, .072DIAX .351 ID, EPDM, DURO90A, VENT PLUG

For the QuarterMaster 6000-meter system, use the following O-ring sizes. The backup O-ring is installed in the same way as shown in Figure 32.

- Transducer and end-cap assembly, face 2-261
- Transducer and end-cap assembly, bore 2-259
- Transducer assembly, backup O-ring, size 259, 90 DURO, BUNA-N type



The backup O-ring is installed on 3000 and 6000 meter high-pressure housing systems in addition to the 2-258 or 2-259 bore O-ring on the end-cap and transducer head assembly. Install the backup O-ring with the cupped side facing the bore seal O-ring as shown in Figure 32.

The 3000 and 6000 meter housings use a different face O-ring (2-261) than the standard 1500 meter housing (2-260).

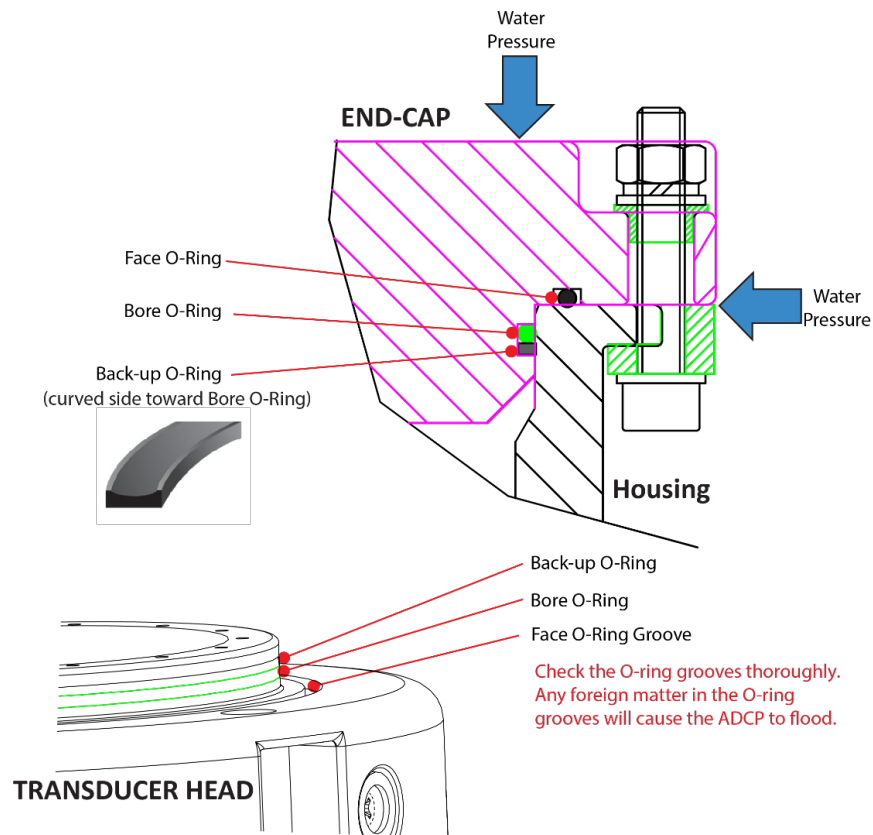

Figure 32. High Pressure O-Ring Detail View

Replacing the Housing Assembly

To replace the housing:

1. Stand the Long Ranger / QuarterMaster transducer assembly on a soft pad.
2. Inspect, clean, and lubricate the O-ring on the housing (see [O-ring Inspection and Replacement](#)). Apply a very thin coat of silicone lube on the O-ring.



TRDI recommends you use new O-rings if you are preparing for a deployment.



Apply a very thin coat of silicone lube on the O-ring. Using too much silicone lube on the O-ring can be more harmful than using no O-ring lube at all.

3. Connect the internal I/O connector to the plug on the electronic chassis high power I/O board (see [Parts Location Drawings](#)).
4. Connect the lanyard on the I/O cable to the High Power Amplifier Assembly.
5. Gently lower the housing onto the transducer, aligning the mating holes. To avoid twisting the internal I/O cable, align the housing's I/O cable access hole (see [Parts Location Drawings](#)) with the I/O cable connector on the electronic chassis. When mating the housing with the transducer head flange try to apply equal pressure to all parts of the O-ring. Make sure the face and bore O-rings remain in their retaining grooves.



Check that no wires or any other object is pinched between the transducer head assembly and the housing. Use rubber bands to hold the wiring in place as necessary. If the O-ring is not in the groove or if a wire or other object is pinched, the ADCP will flood.

6. Examine the housing assembly nuts, bolts, and washers (8 mm) for corrosion; replace if necessary. Figure 33 shows the assembly order of the transducer mounting hardware. *All* hardware items are needed to seal the Long Ranger / QuarterMaster properly.
7. Install all four sets of hardware until “finger tight.”
8. Tighten the bolts in small increments in a “cross” pattern until the split washer flattens out, and then tighten each bolt 1/4 turn more to compress the face seal O-ring evenly. Tighten the bolts to the recommended torque value of 9.6 Newton-meters (85 pound-inches). Do not deform the plastic bushings.



Apply equal pressure to the O-ring as you tighten the bolts. If one bolt is tightened more than the others, the O-ring can become pinched or torn. A damaged O-ring will cause the system to flood.



Do not over tighten the bolts that hold the transducer, housing, and end cap together. If you tighten too far, you can crack or break the plastic bushing. On the other hand, leaving the bolts too loose can cause the system to flood. Tighten the hardware to the recommended torque value.



The recommended torque value for the transducer head 8-mm bolts is 9.6 Newton-meters (85 pound-inches).

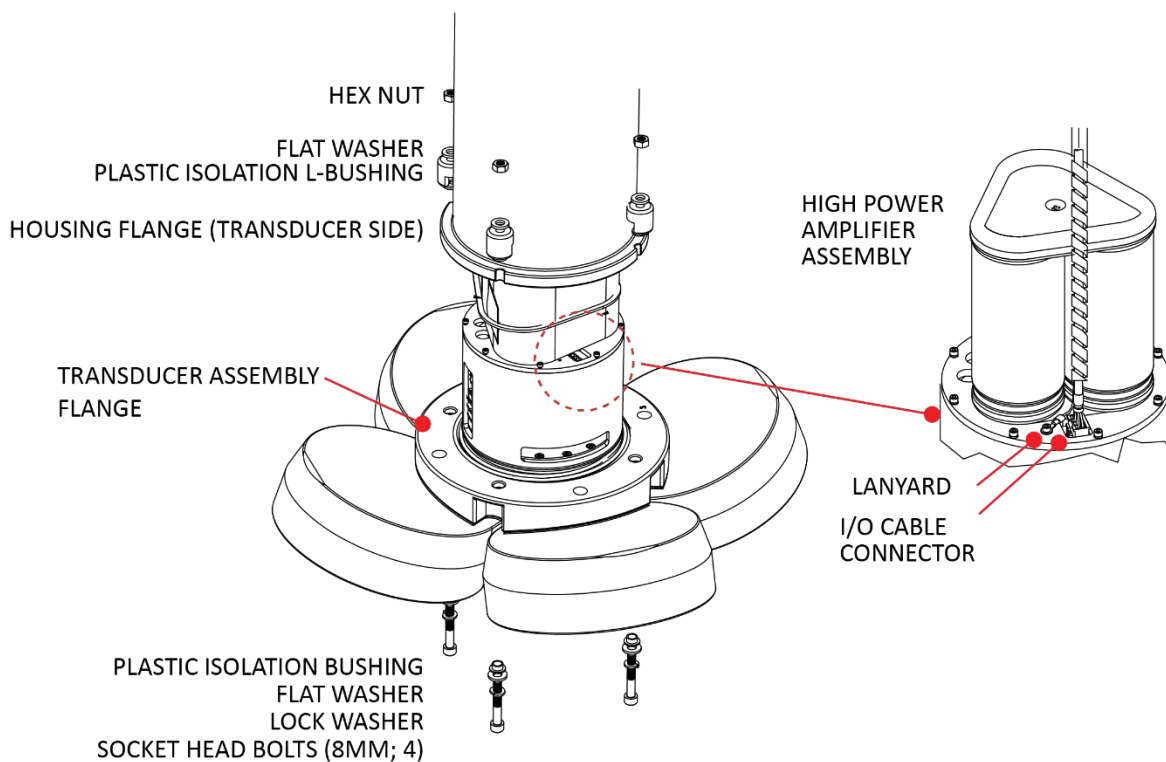

Figure 33. Housing Mounting Hardware

Installing the Battery Pack Modules

To install the battery modules:

1. Place the battery pack installation guides onto the threaded rods. Tighten the guides onto the threaded rod “finger tight” so they will not fall off (see Figure 34, page 70).
2. Slide the battery pack module assemblies onto the rods. Use the battery pack installation guides to help align the battery pack modules onto the threaded rods. As the battery module slides into the housing, make sure the battery module does not pinch any cables.



The top battery pack module has a thicker and larger diameter top plate as well as a shorter battery pack power cable. This module will not slide down as far into the housing as the bottom module.

3. Once both battery pack modules have been installed, remove the battery pack installation guides from the threaded rods. Place the guides in your spare parts kit for safekeeping.
4. Place a flat washer, lockwasher and wing nut on each of the posts. Tighten the nuts to hold the batteries in place.
5. Connect the battery pack power cables to the internal I/O cable.
6. Install the end-cap (see [End-Cap Replacement](#)).
7. Align the compass (see [Compass Calibration](#)).



If you are installing less than four battery cores in the Long Ranger / QuarterMaster, install both battery modules to maintain the proper spacing. Install the battery pack cores closest to the end-cap.

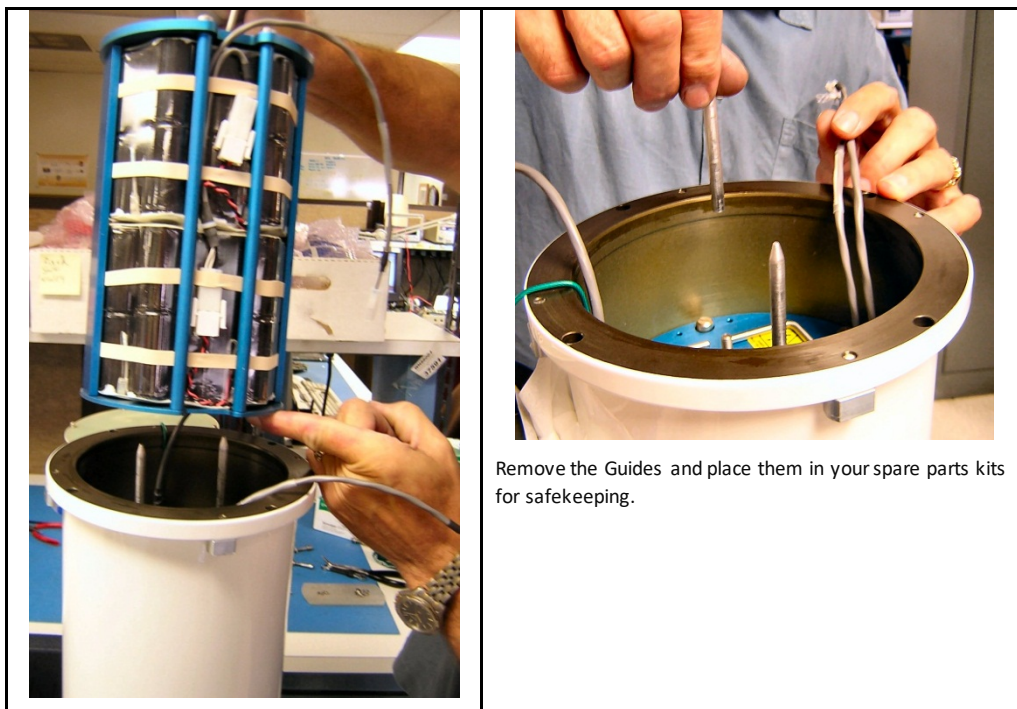

Remove the Guides and place them in your spare parts kits for safekeeping.

Figure 34. Installing the Battery Modules



Two sets of the battery pack installation guides are provided in the Spares Parts kit. If you need to order more sets, use part number 817-6034-00.

Replacing the End-Cap

To replace the end-cap:

1. Stand the Long Ranger / QuarterMaster on its transducer face on a soft pad.
2. Inspect, clean, and lubricate the O-ring on the housing (see [Parts Location Drawings](#)). Apply a very thin coat of silicone lube on the O-ring.



TRDI recommends you use new O-rings if you are preparing for a deployment.



Apply a very thin coat of silicone lube on the O-ring. Using too much silicone lube on the O-ring can be more harmful than using no O-ring lube at all.

3. Connect the lanyard to the end-cap.
4. Connect the internal I/O connector to the plug coming from the electronics chassis and batteries.
5. Install the battery modules and replace the desiccant bag as needed.
6. Place the end-cap on the housing, aligning the mating holes and the beam 3 notch facing the beam 3 number embossed on the transducer head (see [Parts Location Drawings](#)). When mating the end-cap with the housing flange, try to apply equal pressure to all parts of the O-rings. Make sure the O-rings remain in their retaining grooves.



Check that no wires or any other object is pinched between the end-cap and the housing. Use rubber bands to hold the wiring in place as necessary. If the O-ring is not in the groove or if a wire or other object is pinched, the ADCP will flood.

7. Examine the end-cap assembly nuts, bolts, and washers (6 mm) for corrosion; replace if necessary. Figure 35, page 72 shows the assembly order of the end-cap mounting hardware. *All* the hardware items are needed to seal the Long Ranger / QuarterMaster properly.
8. Install all four sets of hardware until “finger-tight.”
9. Tighten the bolts in small increments in a “cross” pattern until the split washer flattens out, and then tighten each bolt ¼ turn more to compress the face seal O-ring evenly. Tighten the bolts to the recommended torque value of 5.6 Newton-meters (50 pound-inches).



Apply equal pressure to the O-ring as you tighten the bolts. If one bolt is tightened more than the others, the O-ring can become pinched or torn. A damaged O-ring will cause the system to flood.





Do not over tighten the bolts that hold the transducer, housing, and end cap together. If you tighten too far, you can crack or break the plastic housing. On the other hand, leaving the bolts too loose can cause the system to flood. Tighten the hardware to the recommended torque value.

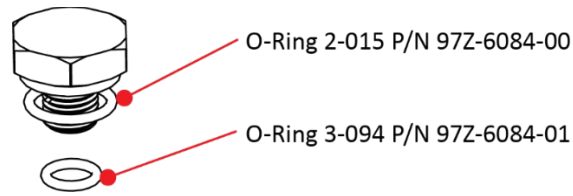

The recommended torque value for the end-cap 6-mm bolts is 5.6 Newton-meters (50 pound-inches).

10. Lubricate and inspect the Vent Plug O-rings. Place the lower Vent Plug O-ring so that it rests on the bottom of the vent plug hole. Check the face Vent Plug O-ring is in the groove on the plug.
11. Install the Vent plug until “finger-tight.”
12. Tighten the Vent Plug to the recommended torque value of 6.8 Newton-meters (60 pound-inches).



 Tighten the Vent Plug to the recommended torque value of 6.8 Newton-meters (60 pound-inches).

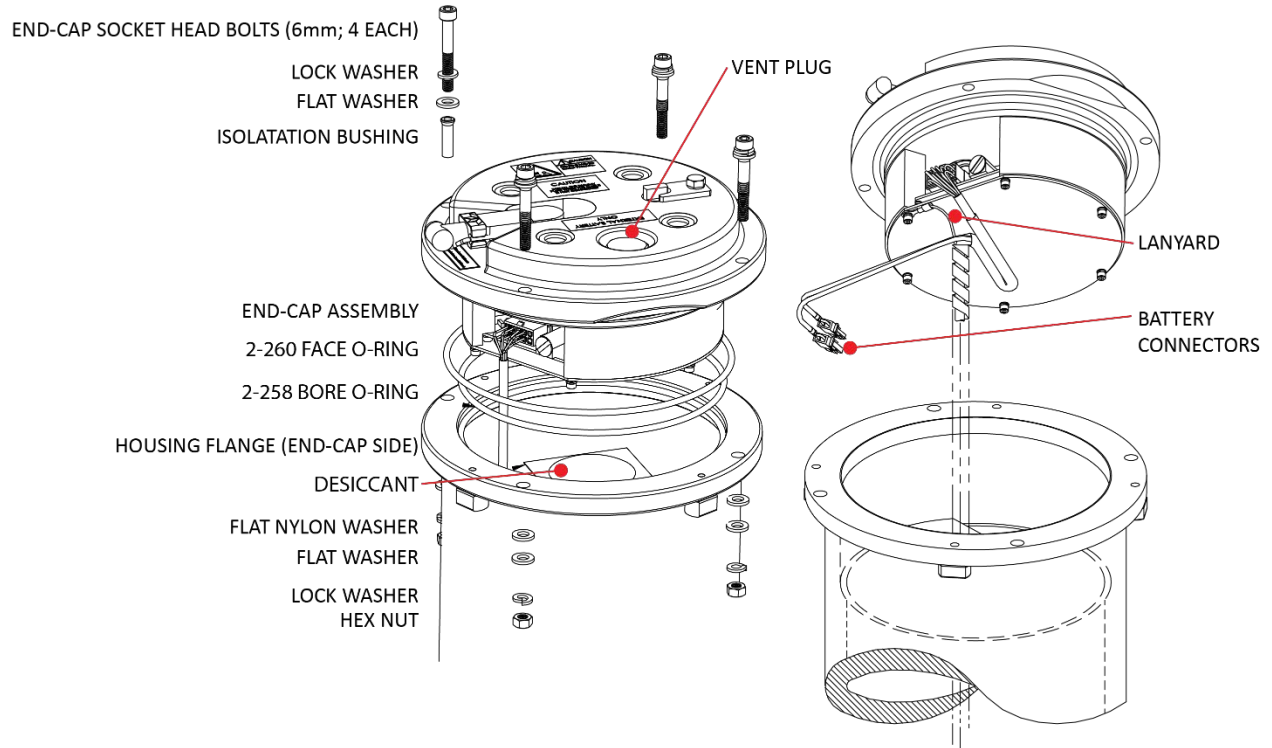

Figure 35. End-Cap Mounting Hardware

Periodic Maintenance Items

Periodic maintenance helps maintain the ADCP so it is ready for a deployment.

Replacing the Battery Cores

The Long Ranger / QuarterMaster SC systems use battery packs to provide power (four or two battery cores depending on the housing length). Alkaline battery pack cores should be replaced when the voltage falls below 30 VDC (measured across the battery pack core connector).



Battery replacement induces both single and double cycle compass errors. The compass accuracy should be verified after replacing the battery pack. The compass does not have to be recalibrated if the compass verification passes specification.

These compass effects can be avoided by using an external battery pack. The external battery housing holds two batteries, and can easily be replaced on-site. If properly used, no compass calibration will be required. The external battery pack provides an option for extended ADCP deployments.



Long Ranger / QuarterMaster batteries are shipped inside the ADCP but not connected. Connect the battery and seal the ADCP before deployment.

To replace the battery core:

1. Remove the end-cap (see [End-Cap Removal Procedures](#)).
2. Remove the battery pack modules (see [Battery Pack Module Removal](#)).
3. Remove the battery pack module's retaining plate by unscrewing the six thumbscrews.
4. Disconnect each battery pack's wiring harness.
5. Slide out the used battery cores (Figure 36).
6. Test the new battery pack voltage by measuring across the battery connector. The voltage should be +42 VDC for a new battery pack and verify the battery is within the Warning date (see [Internal Battery Power Overview](#)).
7. Slide the new battery pack cores into the battery module. Make sure the battery power cable is not pinched by the battery pack. Use rubber bands to hold the wiring in place.
8. Replace the battery pack module's retaining plate. Use the pins to align the retaining plate. Tighten the thumbscrews "hand" tight only.



Although each thumbscrew has a screwdriver slot, do NOT use any tools to tighten the screws. Over-tightening can cause the threads to strip.

9. Install the battery module (see [Battery Pack Module Replacement](#)).
10. Install the end-cap (see [End-cap Replacement](#)).
11. Align the compass (see [Compass Calibration](#)).

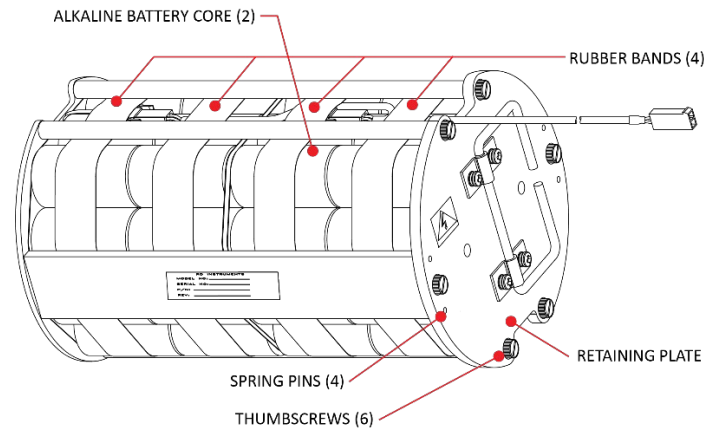

Figure 36. Battery Pack Modules

Using Lithium Battery Packs

The optional Lithium Battery Packs can be used interchangeably in Long Ranger / QuarterMaster systems. This battery pack is assembled using lithium battery cells that provide 34 VDC with a capacity of approximately 1650 Wh. The battery includes a safety circuit that protects the battery and users against short circuits and provides users the ability to test the pack. The circuit also turns the battery off at its end of life, before the battery fully discharges. This happens when about 97% of the battery's capacity is depleted.

The Lithium packs are too large to fit inside the Long Ranger / QuarterMaster battery holders, but they can be installed directly inside the housing without using the holders. Use the retaining plate from the top battery module to hold the batteries in place. This works well because the lithium battery packs are light. They are 60% less weight than an alkaline pack.

To install Lithium batteries:

1. Remove the battery pack modules.
2. Place the battery pack installation guides onto the threaded rods. Tighten the guides onto the threaded rod "finger tight" so they will not fall off.
3. Test the Lithium battery pack before connecting the wiring harness (see [Testing the Lithium Battery Pack](#)).
4. Lay the ADCP on its side and slide the Lithium battery packs onto the rods. Make sure the battery power cable is not pinched as it slides into the housing. Use rubber bands to hold the wiring in place.
5. Remove the six thumbscrews on the top battery pack module's retaining plate and then use this plate to hold the lithium batteries in place (see Figure 36).



Save the unused battery pack modules and screws in a safe location. They are required for use with the alkaline batteries.

6. Remove the battery pack installation guides from the threaded rods. Place the guides in your spare parts kit for safekeeping.
7. Place a flat washer, lockwasher and wing nut on each of the posts. Tighten the nuts to hold the batteries in place.
8. Connect the battery pack power cables to the internal I/O cable.
9. Install the end-cap (see [End-Cap Replacement](#)).



Disposal of used battery packs should be done in accordance with applicable regulations, which vary from country to country. In most countries trashing of used batteries is forbidden and disposal can be done through non-profit organizations mandated by local authorities or organized by professionals.



Figure 37. Workhorse Lithium Battery Pack



The optional Lithium battery packs are restricted to Cargo Aircraft Only since 1 January 2015. **Do NOT return ADCP units with the optional Lithium battery pack installed.**

Testing the Lithium Battery Pack

The optional Lithium battery pack includes a safety circuit that turns the battery off at its end of life, before the battery fully discharges. This happens when about 97% of the battery's capacity is depleted. The circuit also protects the battery and users against short circuits and provides users the ability to test the pack. When the battery detects a short circuit, it waits about 300 us, and then it turns itself off. A red LED on the circuit indicates when it detects a short. The circuit monitors the load across the battery and as soon as the load is removed, it displays the results of its self-test.

Before installing the Lithium battery pack run the self-test by shorting the battery's pins with a bent paperclip. The LED display lasts approximately 10 seconds and indicates the battery status:

- A continuous green LED tells you the battery is new.
- A flashing green LED tells you the battery has been used, but can still power an ADCP.
- A continuous red LED tells you the battery has been disconnected at its end of life and cannot be used any more.
- If there is no LED light at all, the circuit is defective and you should not use the battery.



You should run the self-test when you receive new Lithium battery packs. This way, there is time to replace defective batteries before you deploy. You should also run the self-test just before installing the battery.

Replacing the External Battery Case Cores

The optional external battery case holds two battery modules to provide power. Battery cores should be replaced when the voltage falls below +30 VDC (measured across the battery connector). See the [Parts Location Drawings](#) for reference.



The external battery case should not be connected or disconnected underwater. The electrical output power will degrade the connector contacts and present a potential electrical shock hazard to installation personnel when the power connector is short-circuited in water. The external battery case output power cannot be enabled or disabled underwater.

To replace the external battery case battery packs:

1. Remove the battery side end-cap from the external battery case (see [End-Cap Removal Procedures](#)).
2. Place the external battery case on its side and remove the retaining plate. Carefully pull out the battery pack modules (see [Battery Pack Module Removal](#)).
3. Replace the battery pack cores as needed (see [Battery Core Replacement](#)).
4. Replace the desiccant bags inside the housing just before sealing the external battery case (see [Desiccant Bags](#)).
5. Install the end-cap (see [End-Cap Replacement](#)).



The external battery case, battery side end-cap is different than the standard Long Ranger / QuarterMaster end-cap. Figure 49 shows the standard Long Ranger / QuarterMaster end-cap. The common mode choke coil is very visible behind the internal I/O cable connector and fuse. The common mode choke coil is NOT installed on the battery side end-cap.

Do not swap external battery case end-caps with transducer housing end-caps!

Calibrating the Compass

The main reason for compass calibration is battery replacement. Each new battery carries a different magnetic signature. The compass calibration algorithm corrects for the distortions caused by the battery to give you an accurate measurement. You should be aware of the following items:

- TRDI recommends **against** calibrating the Long Ranger / QuarterMaster while on a ship. The ship's motion and magnetic fields from the hull and engine will likely prevent successful calibration or **will provide an improper calibration for the heading sensor once the ADCP operates away from the ship.**
- If you think your mounting fixture or frame has some magnetic field or magnetic permeability, calibrate the Long Ranger / QuarterMaster inside the fixture. Depending on the strength and complexity of the fixture's field, the calibration procedure may be able to correct it.
- A good compass calibration requires slow, smooth movement to allow the compass to collect data at each point.
- Calibrate the compass as close to the location that it will be deployed and as far away as possible from objects that have magnetic fields that could result in a poor calibration. **Common objects to avoid calibrating the compass near include steel reinforced concrete, buildings, and automobiles.**
- **Completing the calibration rotation(s) does not guarantee an acceptable compass error.** Compass error is based not only on the quantity of measurements made during the calibration but also the quality of the magnetic environment. Attempting to calibrate the compass in a poor environment, e.g., near fixed ferrous objects, will likely result in an unacceptable compass error regardless of how well the calibration is performed.
- The Single-tilt calibration is intended for applications where tilting the unit is not practical. This calibration is only applicable to the tilt orientation the unit is rotated about during the calibration.

Compass Background

The compass calibration algorithm collects magnetic field vector information for various measured headings during the calibration. Hard and soft iron effects rotating with the compass are made observable during the calibration by causing the local field to be perturbed as the compass is spun during the calibration. That is, each component of the hard and soft iron has to alternately increase the local field for some orientations and decrease for orientations 180 degrees (or 90 degrees for soft iron) from those orientations for the algorithm to "notice" it. Tilting and rotating the compass about the vertical axis is sufficient to do this.

There are three compass calibrations to choose from; one only corrects for hard iron while the second corrects for both hard and soft iron characteristics for materials rotating with the ADCP. The third method provides calibration for a [single tilt orientation](#). Hard iron effects are related to residual magnetic fields and cause single cycle errors while soft iron effects are related to magnetic permeability that distorts the earth's magnetic field and causes double cycle errors. In general, the hard iron calibration is recommended because the effect of hard iron dominates soft iron. If a large double cycle error exists, then use the combined hard and soft iron calibration.

Preparing for Calibration



Use the shipping case or a calibration stand to rotate the Long Ranger / QuarterMaster during calibration—this way you will not scratch or drop the Long Ranger / QuarterMaster.



If you will deploy your Long Ranger / QuarterMaster looking up, calibrate it looking up. If you will deploy it looking down, calibrate it looking down.



If you calibrate the compass in one direction (up or down) and deploy the ADCP in the opposite direction (i.e. calibrate it in a downward position and deploy it in an upward

position) the compass calibration will be invalid. Compass errors in excess of 5 degrees may occur.



LR-1A is shown with Teledyne Long Ranger loaded for a UPWARD Profile Calibration

LR-1B is shown with Teledyne Long Ranger loaded for a DOWNWARD Profile Calibration



Compass calibration stands are not required to calibrate the Long Ranger / QuarterMaster compass, but they do make it much easier and increase the calibration accuracy. Calib Designs is one source for calibration stands. Contacting this company is done with the knowledge that Teledyne RD Instruments is not recommending them, but only offering this as a source for the stand.

<http://www.calibdesigns.com/index.html>

To prepare for compass calibration:

1. Position the shipping case on the floor as far away from metal objects as possible.
2. Remove the vent on the side of the shipping case and use the hole to feed through the power and I/O cable.
3. Place the Long Ranger / QuarterMaster inside the shipping case. Place all the foam inserts around the Long Ranger / QuarterMaster to keep the instrument from shifting inside the case. If you are doing a compass *verification*, the Long Ranger / QuarterMaster can be straight or tilted inside the case. For the compass *calibration*, the Long Ranger / QuarterMaster must be tilted inside the case (see Figure 40 and Figure 41).
4. Connect the Long Ranger / QuarterMaster as shown in [Setting up the Long Ranger / QuarterMaster System](#).
5. Close and securely latch the shipping case cover.

6. **Tip the shipping case on its end so that the Long Ranger / QuarterMaster is in the same orientation as it will be when deployed.** The Long Ranger / QuarterMaster can rest on its end cap (deployed looking up), or it can rest on the transducer face (deployed looking down) inside the shipping case.



Do not tip the shipping case on its end without the cover in place and securely latched. The Long Ranger / QuarterMaster may fall out of the case causing damage to the instrument or personal injury.



Weight in air for a LongRanger/QuarterMaster system is between 38.5 Kg (85 pounds) to 124.7 Kg (275 pounds). Use lifting aids and proper lifting techniques when moving.

Compass Calibration Verification

Compass calibration verification is an automated built-in test that measures how well the compass is calibrated. The procedure measures compass parameters at every 5° of rotation for a full 360° rotation. When it has collected data for all required directions, the Long Ranger / QuarterMaster computes and displays the results.



Verify the compass if you have just replaced the memory module or any ferrous metals is relocated inside or around the Long Ranger / QuarterMaster housing. **Calibrate** the compass if the batteries have been replaced (see [Compass Calibration Procedure](#)).

To verify the compass calibration:

1. Prepare the ADCP for calibration (see [Preparing for Calibration](#)).
2. Using *TRDI Toolz*, send a Break to wake up the Long Ranger / QuarterMaster.
3. At the > prompt, type **AX** and press the **Return** key.
4. When prompted, rotate the Long Ranger / QuarterMaster slowly 360 degrees (approximately 5 degrees per second). Pay particular attention to the Overall Error. For example;

HEADING ERROR ESTIMATE FOR THE CURRENT COMPASS CALIBRATION:

OVERALL ERROR:

```

Peak Double + Single Cycle Error (should be < 5()): ( 1.55(
DETAILED ERROR SUMMARY:
Single Cycle Error: ( 1.54(
Double Cycle Error: ( 0.07(
Largest Double plus Single Cycle Error: ( 1.61(
RMS of 3rd Order and Higher + Random Error: ( 0.31(

```

If the overall error is less than 2°, the compass does not require alignment. You can align the compass to reduce the overall error even more (if desired).

Compass Calibration

The built-in automated compass calibration procedure is similar to the alignment verification, but requires three rotations instead of one. The Long Ranger / QuarterMaster uses the first two rotations to compute a new calibration matrix and the third to verify the calibration. It will not accept the new matrix unless the calibration was carried out properly, and it asks you to verify that you want to use the new calibration if it is not as good as the previous calibration. While you are turning the Long Ranger / QuarterMaster for the two calibration rotations, the Long Ranger / QuarterMaster checks the quality of the previous calibration and displays the results. It compares these results with the results of the third calibration rotation.

To calibrate the compass:

1. Using *TRDI Toolz*, send a Break to wake up the ADCP.
2. At the > prompt, type **AR** and press the **Return** key. This will return the compass to the factory calibration matrix.
3. At the > prompt, type **AF** and press the **Return** key. Choose option “a” or “b” to start the calibration procedure.

Field Calibration Procedure
Choose calibration method:

- a. Remove hard iron error (single cycle) only.
- b. Remove hard and soft iron error (single + double cycle).
- c. Calibration for a single tilt orientation (single + double cycle).
- d. Help.
- e. Quit.



In general, the hard iron calibration is recommended because the effect of hard iron dominates soft iron.

If the batteries have just been replaced, then use the combined hard and soft iron calibration. Changing the batteries should only change the hard-iron signature of the ADCP, but can induce both single and double cycle compass errors.

4. Use the following steps to orientate the Long Ranger / QuarterMaster for the first rotation of the compass calibration.
 - a. Place the Long Ranger / QuarterMaster inside the shipping case.
 - b. Tilt the Long Ranger / QuarterMaster using the cutout in the foam inside the shipping case (see Figure 40 and Figure 41). The Direct-Reading Long Ranger / QuarterMaster shipping case requires that the side foam insert be pulled out and placed on the other side of the case in order to tilt the Long Ranger / QuarterMaster.
 - c. Place all the foam inserts around the Long Ranger / QuarterMaster to keep the instrument from shifting inside the shipping case.
 - d. Close and securely latch the shipping case.
 - e. Tip the shipping case on its end and keep the same orientation as it will be deployed in (the Long Ranger / QuarterMaster can rest on its end cap (deployed looking up), or it can rest on the transducer face (deployed looking down) inside the shipping case (see Figure 40 and Figure 41).
 - f. Check the on-screen instructions to see if the Long Ranger / QuarterMaster orientation is OK. Adjust as necessary.
5. When prompted, rotate the Long Ranger / QuarterMaster slowly 360 degrees (approximately 5 degrees per second) using the shipping case to assist in rotating the Long Ranger / QuarterMaster (see Figure 38).

6. The second rotation requires the Long Ranger / QuarterMaster to be tilted 15 degrees in another direction than from the first rotation.
 - a. Place the shipping case on the floor.



Do not open the shipping case when the case is tipped on its end. The Long Ranger / QuarterMaster may fall out of the case causing damage to the instrument or personal injury.



Weight in air for a LongRanger/QuarterMaster system is between 38.5 Kg (85 pounds) to 124.7 Kg (275 pounds). Use lifting aids and proper lifting techniques when moving.

- b. Open the shipping case.
 - c. Rotate the Long Ranger / QuarterMaster so that another beam is in the center of the rotation.
 - d. Place all the foam inserts around the Long Ranger / QuarterMaster to keep the instrument from shifting inside the shipping case.
 - e. Close and securely latch the shipping case.
 - f. Tip the shipping case on its end keeping the same Long Ranger / QuarterMaster orientation as it was before (i.e. if the previous rotation had the Long Ranger / QuarterMaster on its end-cap, make sure the Long Ranger / QuarterMaster is still on its end-cap).
7. When prompted, rotate the shipping case slowly 360 degrees (approximately 5 degrees per second).
8. The third rotation requires the Long Ranger / QuarterMaster to be tilted 15 degrees in another direction than from the first and second rotations. Follow the steps as per the second rotation and the on-screen instructions to orient the Long Ranger / QuarterMaster correctly. When prompted, rotate the Long Ranger / QuarterMaster slowly 360 degrees (approximately 5 degrees per second).
9. If the calibration procedure is successful, it records the new calibration matrix to nonvolatile memory. The Long Ranger / QuarterMaster will not change its matrix unless the calibration is properly carried out.
10. If the calibration procedure is not successful, return your Long Ranger / QuarterMaster to the original factory calibration, by using the AR-command. Try using the AR-command if you have trouble calibrating your compass. In some circumstances, a defective compass calibration matrix can prevent proper calibration.



Figure 38. Rotating the Long Ranger / QuarterMaster Shipping Case During Compass Calibration



Direct-Reading case shown.

Single-Tilt Compass Calibration Procedure

This procedure is used to correct the ADCP's internal flux-gate compass for one-cycle deviation errors. The compass correction procedure given here can be used in place of the [Compass Calibration](#) procedures if you are using a Long Ranger / QuarterMaster ADCP with firmware version 16.30 or higher.

During this procedure, the ADCP must be rotated in a complete 360 circle no faster than 5 degrees per second. This calibration can be done in the water (recommended) or on shore. It is important to reduce any pitch and roll effects during the turn and avoid any acceleration.



This calibration is intended for applications where tilting the unit is not practical. This calibration is only applicable to the tilt orientation the unit is rotated about during the calibration.



Single tilt calibration does a hard-iron correction only. Changing the Long Ranger / QuarterMaster batteries should only change the hard-iron signature of the ADCP, but can induce both single and double cycle compass errors. A single-tilt calibration should suffice, but performing a full [hard and soft iron calibration](#) is always a safer route whenever possible.

To calibrate the compass:

1. Mount the ADCP in the boat as it will be used to acquire data.
2. Start *TRDI Toolz*.
3. At the ">" prompt, type **AR** and press the **Return** key. Type **Y** to return the Fluxgate Calibration Matrices with the factory original values.

>AR

```
Do you really want to write over the active fluxgate calibration
data [y or n]?Y
```

```
Fluxgate Calibration Matrices Updated with Factory Original Values.
```

>

4. At the ">" prompt, type **AF** and press the **Return** key. Select option "c" Calibration for a single tilt orientation (single + double cycle).

```
Field Calibration Procedure
```

```
Choose calibration method:
```

- a. Remove hard iron error (single cycle) only.
- b. Remove hard and soft iron error (single + double cycle).
- c. Calibration for a single tilt orientation (single + double cycle).
- d. Help.
- e. Quit.

c

5. During the calibration, drive the boat in a continuous small circle. You can accomplish this by adjusting the throttle to just above idle and steering either hard left or hard right. You will want to reduce any pitch and roll effects during the turn. Do not move about the boat as this may cause the boat to change how it sits in the water. Avoid any accelerations during the calibration. If you are working on a river, you will find that you drift downstream as you perform the circles. This will not affect the calibration.
6. While you continue to drive the boat in circles, press any key to start the compass calibration. Follow the on screen prompts.
7. Press **D** for details.

```
HEADING ERROR ESTIMATE FOR THE CURRENT COMPASS CALIBRATION:
```

```
OVERALL ERROR:
```

```
Peak Double + Single Cycle Error (should be < 5ø): ñ 1.73ø
```

```
DETAILED ERROR SUMMARY:
```

Single Cycle Error:		ñ 1.70ø
Double Cycle Error:		ñ 0.42ø
Largest Double plus Single Cycle Error:		ñ 2.12ø
RMS of 3rd Order and Higher + Random Error:		ñ 0.77ø
Orientation:	Down	
Average Pitch:	-0.18ø	Pitch Standard Dev: 0.37ø
Average Roll:	0.35ø	Roll Standard Dev: 0.45ø

Successfully evaluated compass performance for the current compass calibration.

Press C to display Percent Horizontal Field Components
 Relative to Calibration or any other key to continue....
 Calibration parameters have been updated in NRAM.

>

8. You can now use the ADCP with its corrected compass.

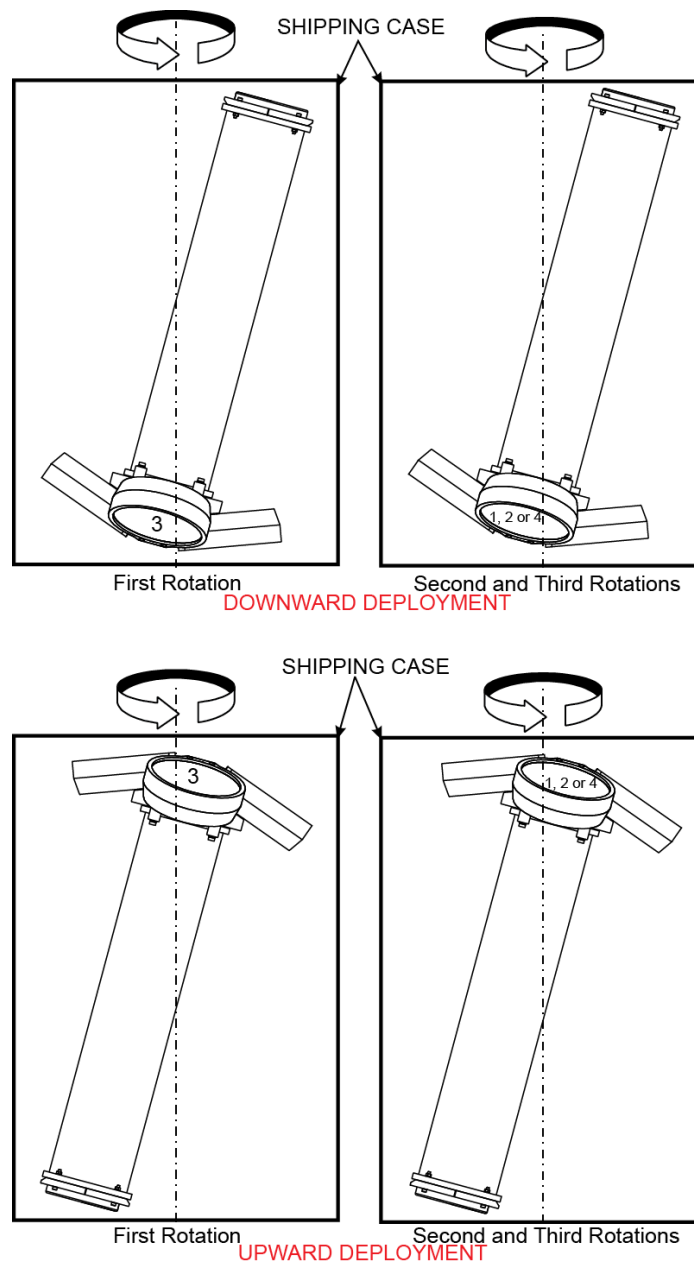

Figure 39. Compass Calibration



Figure 40. Self-Contained Long Ranger / QuarterMaster Tilted Position in Shipping Case

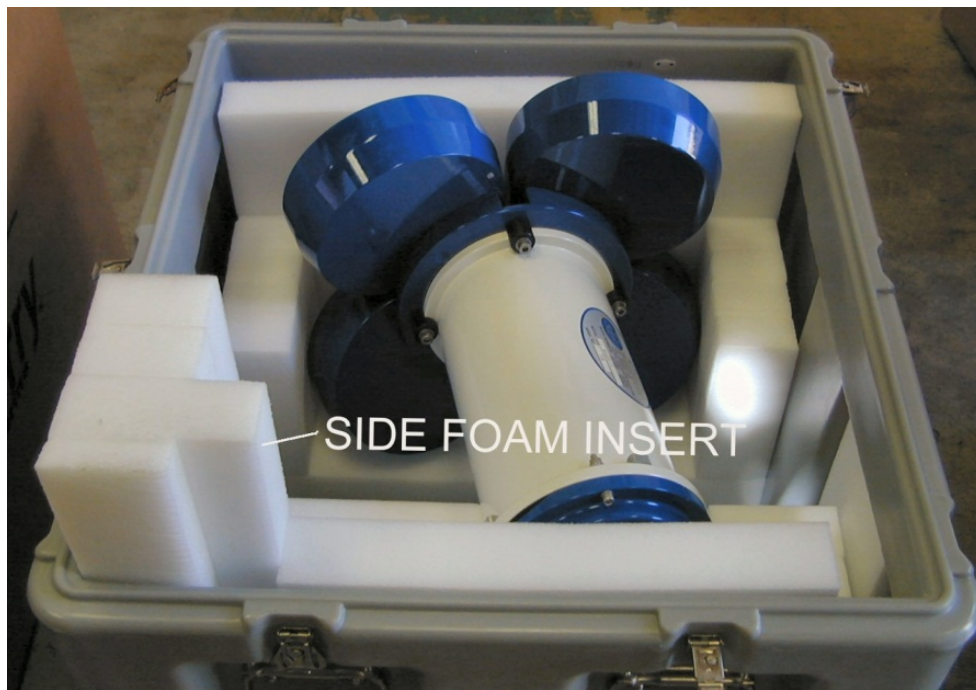

Figure 41. Direct-Reading Long Ranger / QuarterMaster Tilted Position in Shipping Case



To tilt the Direct-Reading Long Ranger / QuarterMaster, move the side foam insert from the right side to the left.

Replacing the Desiccant Bags

Desiccant bags are used to dehumidify the housing interior. Desiccant is essential in deployments with plastic housings. The factory-supplied desiccant lasts a year at specified Long Ranger / QuarterMaster deployment depths and temperatures. Remember that desiccant rapidly absorbs moisture from normal room air.

The average dry weight of a new desiccant bag is 7.2 grams ((5%). The weight increases to 8.4 to 9 grams for a “used” desiccant bag. Used desiccant bags may be dried at 250° for 14 hours. As a minimum, replace the desiccant bags (Table 1, item 6) whenever you are preparing to deploy or store the Long Ranger / QuarterMaster for an extended time.



Do not open the desiccant bag. Contact with the silica gel can cause nose, throat, and skin irritation.

Do not puncture or tear the desiccant bag. Do not use desiccant bags that are torn or open.



Desiccant bags are shipped in an airtight aluminum bag to ensure maximum effectiveness. There is a moisture indicator inside the bag. If the moisture indicator is pink, do not use the desiccant bag until it has been dried. TRDI recommends replacing the desiccant bag just before the deployment.

To replace the desiccant:

1. Remove the end-cap (see [End-Cap Removal Procedures](#)).
2. Remove a new desiccant bag from the airtight aluminum bag and place the desiccant bag on top of the battery modules.
3. Install the end-cap (see [End-Cap Replacement](#)).



Cleaning the Pressure Sensor Port

In order to read the water pressure, water must be able to flow through the transducer anode and cover disk over the pressure sensor. The holes in the anode and cover disk (see Figure 42) may at times be blocked.

To clean the pressure sensor port:

1. Place the Long Ranger / QuarterMaster on its' side. Use a soft pad to protect the ADCP.
2. Use a Phillips-screwdriver to remove the transducer anode (see [Zinc Anode Replacement](#)).
3. Remove the two nylon screws holding the cover disk in place.



The pressure sensor installed on the Long Ranger / QuarterMaster ADCPs is installed in a cavity that includes a protective cap to prevent particles from collecting on top of the pressure sensor itself. This covering is made of Delrin and is held into place with two nylon screws. The holes where the nylon screws are inserted are anodized aluminum.

TRDI knows from our experience that it is difficult to anodize sharp edges on threaded holes such as these. In marine and fresh water environments, poor anodizing on aluminum will lead to corrosion problems. Always inspect for corrosion in this (and all) areas between deployments.

4. Look for signs of corrosion such as white deposits. If corrosion caused part of the housing to be visibly damaged, do not redeploy your system. Send it back to TRDI for inspection (see [Returning ADCPs to TRDI for Service](#)).
5. Clean both nylon screw mounting holes with a thin brush and lime based product. Flush the holes with the lime based product if you do not have a brush available. Be sure clean and remove any signs of corrosion.
6. Gently clean out the hole in the anode and cover disk with a needle (only clean after these have been removed from the transducer assembly). If cleaning causes the hole to be enlarged in either the cover disk or the anode or if the anode is corroded, replace the item.
7. Install the black cover disk above the pressure port.
8. Brush the nylon screws with marine environment grease such as Aqua Shield grease. Use gloves as it tends to stick to your skin. Note that the grease is incompressible and therefore apply a thin layer to the screws to avoid binding or difficulty in the installation of the nylon screws in the mounting holes.
9. Tighten the nylon screws "finger tight" (2 in/lbs). Do not over-tighten the screws or you may strip the threads on the nylon screws.
10. Install the transducer anode (see [Zinc Anode Replacement](#)).
11. Zero the pressure sensor. Use the AZ-command to zero out the pressure sensor at the deployment site, before putting the ADCP into the water.
 - a. Connect and apply power to the system.
 - b. Start *TRDI Toolz* and send a Break to wake up the ADCP.
 - c. Type AZ and press the Return key.
 - d. Exit *TRDI Toolz*.



The pressure sensor is filled with silicone oil. Never poke a needle or other object through the anode or cover disk while the items are installed over the pressure sensor. You will perforate the sensor, causing it to fail or create a leakage path.

Do not attempt to clean the surface of the pressure sensor. The diaphragm is very thin and easy to damage.

If the pressure sensor surface looks corroded or is bowed outward, then contact TRDI for servicing.

Do not attempt to remove the pressure sensor. It is not replaceable in the field.

Always inspect for corrosion in this (and all) areas between deployments.

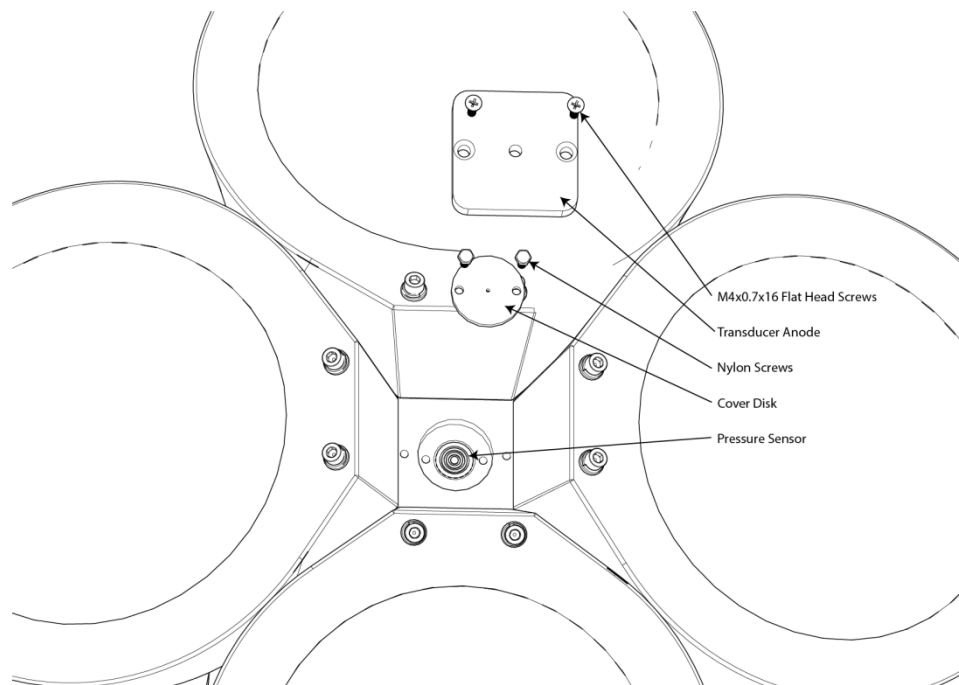

Figure 42. Long Ranger / QuarterMaster Pressure Sensor

Purge Plug Inspection & Replacement

The purge plug is a safety valve and is designed to push out of the system to ensure that there is not excessive pressure inside the system when removing the end cap. **Replace the purge plug O-Rings every two to three years.**

To replace the purge plug O-rings:

1. Remove the M4 plastic screw(s) and flat washer (single-screw purge plug only).
2. Lift off the plug keeper.
3. Remove the purge plug. Remove the old O-rings.
4. Clean and inspect the purge plug. Be sure the O-ring groove is free of foreign matter, scratches, indentations, and pitting. Replace the purge plug if it shows any signs of damage. Look for signs of corrosion such as white deposits in the purge plug housing. If corrosion caused part of the purge

plug housing to be visibly damaged, do not redeploy your system. Send it back to TRDI for inspection (see [Returning Systems to TRDI for Service](#)).



Check the O-ring groove thoroughly. Any foreign matter in the O-ring groove will cause the ADCP to flood.

- Lubricate the O-ring with a thin coat of silicone lubricant. Apply the lubricant using latex gloves. Do not let loose fibers or lint stick to the O-ring. Fibers can provide a leakage path.



Apply a very thin coat of silicone lube on the O-ring. Using too much silicone lube on the O-ring can be more harmful than using no O-ring lube at all.

- Install the backup O-ring first as shown below and then install the bore O-ring.
- Insert the purge plug into the housing/end-cap. Install the plug keeper and flat washer (single-screw purge plug only).
- Apply a drop of 425 thread locker on the M4 screw(s). Tighten the screws to 0.5 ± 0.1 N.m ($4.0 \pm .5$ IN-LB)

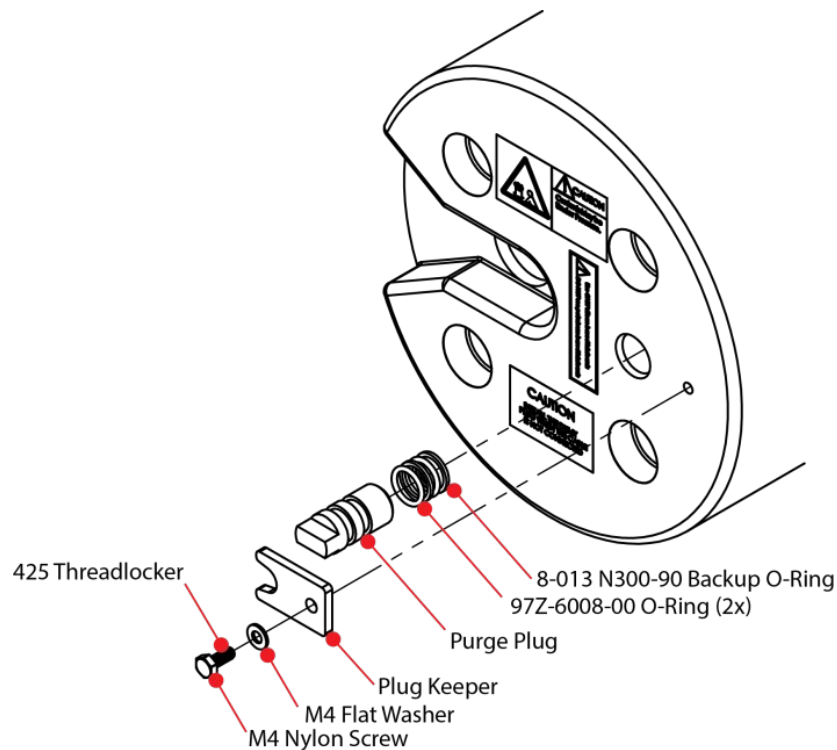

Figure 43. Purge Plug O-Ring Replacement

Protective Coating Inspection and Repair

TRDI uses paint on the Long Ranger / QuarterMaster housing for identification and corrosion protection. For more protection, the case and the transducer assembly are first anodized per MIL-A-8625, Type 3, Class 1 and sealed with sodium dichromate. Do not damage the surface coatings when handling the Long Ranger / QuarterMaster.

Inspect the end-cap, housing, and transducer assemblies for corrosion, scratches, cracks, abrasions, paint blisters, exposed metal (silver-colored aluminum), exposed anodize (black or dark green), and exposed primer (light blue or yellow for 6000 meter systems). **Be critical in your judgment; the useful life of the Long Ranger / QuarterMaster ADCP depends on it.**



The procedures contained in this section apply to our standard aluminum systems. For systems made of other materials, contact TRDI. Read all instructions before doing the required actions.



The chemicals used in the following steps can be hazardous to your health. Read all material safety data sheets and manufacturer's instructions before handling these chemicals.



If there is any damage to the paint near the edges of the urethane transducer cups or the I/O connector, **DO NOT DEPLOY THE ADCP**. Return the Long Ranger / QuarterMaster to TRDI for repair.

To repair or touch up the protective paint:

1. Remove all loose paint without damaging the anodizing. Clean and prepare the damaged area using a fine-grade abrasive cloth. Feather the edges of the paint near the damaged area. Try to have a smooth transition between the paint and the damaged area. Do not sand the anodized area. If there is damage to the anodizing, return the Long Ranger / QuarterMaster to TRDI for repair.
2. Clean the area with alcohol. Do not touch the area after cleaning.
3. Mix the epoxy primer Part A and Part B using a 1:1 mix. Paint one coat of epoxy primer (see note below). Allow the primer to dry thoroughly before continuing.
4. Mix the colored paint using two parts color and 1 part catalyst. Paint with one coat of colored paint (see note below).



The catalyst (hardener) will rapidly harden in air. Mix only the amount of paint you need and work quickly.



TRDI uses two-part epoxy type paint. This paint is manufactured by Sherwin-Williams Proline Paint Store, 2426 Main St., San Diego, CA, 92113-3613, Telephone: +1 (619) 231-2313.

Primer Manufacturer's part numbers:
F-158 for 6000 meter systems (part A and part B)
3061 for all other systems (part A and part B)

Colored paint Manufacturer's part numbers:
4800HS, Catalyst,
4800-19, Yellow (6000 meter systems)
4800-28, Orange (3000 meter systems)
4800-01, Snow White (1500 meter systems)
4800-25, Bright Blue (transducer assembly)

Contact the paint manufacturer for preparation and application procedures for this and other paints. Contacting this company is done with the knowledge that Teledyne RD Instruments is not recommending them, but only offering this as a source for the paint.

Zinc Anode Inspection and Replacement

The standard Long Ranger / QuarterMaster has nine sacrificial zinc anodes: one on the transducer assembly, four on the end-cap assembly, and four on the housing flange. If the Long Ranger / QuarterMaster does not have exposed bare metal, properly installed anodes help protect the Long Ranger / QuarterMaster from corrosion while deployed. Read all instructions before doing the required actions.



The 3000-meter Long Ranger / QuarterMaster also has nine sacrificial zinc anodes; one on the transducer assembly, four on the end-cap assembly, and four embedded in the housing. The instructions for inspection and replacement of the Long Ranger / QuarterMaster 3000-meter anodes are the same as for the standard Long Ranger / QuarterMaster.

Zinc Anode Inspection

The life of a zinc anode is not predictable. An anode may last as long as one year, but dynamic sea conditions may reduce its life. Use a six-month period as a guide. If the total deployment time for the anodes has been six months or more, replace the anodes. If you expect the next deployment to last six months or more, replace the anodes.

To inspect the anodes:

1. Inspect the anodes on the transducer assembly, housing and end-cap for corrosion and pitting. If most of an anode still exists, you may not want to replace it.
2. Inspect the RTV-covered screws that fasten each anode. If the RTV has decayed enough to let water enter between the screws and the anode, replace the RTV.
3. If you have doubts about the condition of the anodes, remove and replace the anode.

Zinc Anode Electrical Continuity Check

Check electrical continuity using a digital multi-meter (DMM). Scratch the surface of the anode with the DMM probe to make good contact if the anode is oxidized. All measurements must be less than five ohms. If not, reinstall the affected anode.

End-Cap Anode. Remove the end-cap (see [End-Cap Removal Procedures](#)). Measure the resistance between the anode and the nut on the I/O cable connector on the inside of the end-cap.

Housing Anodes. Measure the resistance between all four anodes.

Transducer Anode. Remove the housing (see [Housing Assembly Removal](#)). Measure the resistance between the anode and any one of the four screws holding the PC boards to the transducer.

Zinc Anode Replacement

To remove and replace the zinc anode/s:

1. Remove the RTV from the anode screw heads. Remove the screws.
2. The anode may stick to the Long Ranger / QuarterMaster because of the RTV used during assembly. To break this bond, first place a block of wood on the edge of the anode to protect the housing anodizing and paint. Carefully strike the block to loosen the anode.
3. Clean the bonding area under the anode. Remove all foreign matter and corrosion. Apply a continuous 1 to 2 mm bead (0.04-0.08 in.) of RTV around each screw hole.
4. Set a new anode in place and fasten with new screws.
5. Fill the counter bore above each screw head with RTV. The RTV protects the screw heads from water and prevents breaking the electrical continuity between the anode, screw, and housing.



Do not cover the top surface of the anode with RTV. The anode must contact seawater.

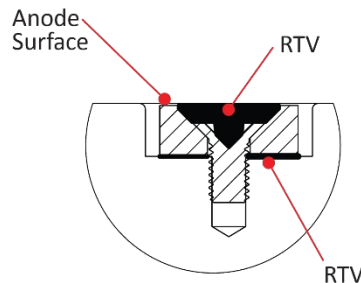

6. Check the electrical continuity. If any measurement is greater than one ohm, reinstall the affected anode.



Do not connect other metal to the Long Ranger / QuarterMaster. Other metals may cause corrosion damage. Use isolating bushings when mounting the Long Ranger / QuarterMaster to a metal structure.



Do not use zinc anodes with an iron content of more than 0.0015%. The major factor controlling the electrical current output characteristics of zinc in seawater is the corrosion film that forms on the surface of the zinc. Corrosion product films containing iron have a high electrical resistance. As little as 0.002% iron in zinc anodes degrades the performance of the anode.

Do not use magnesium anodes. Magnesium rapidly corrodes aluminum housings.

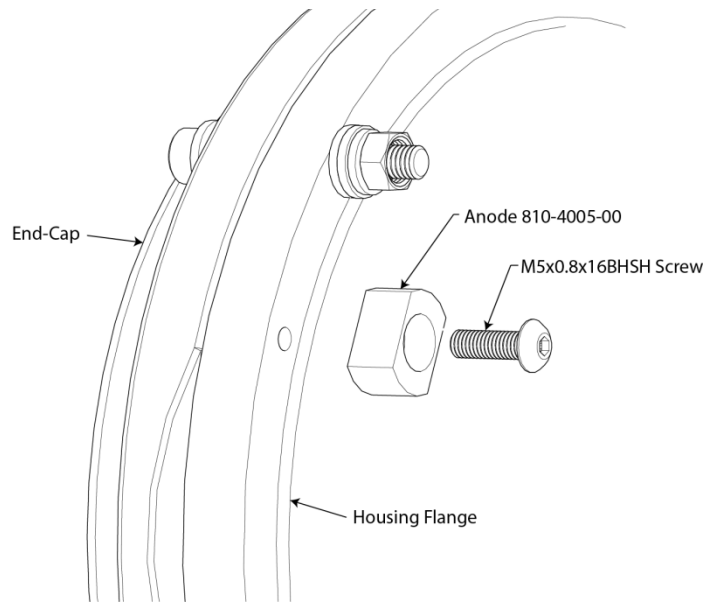

Figure 44. 1500 meter Housing Flange Anodes

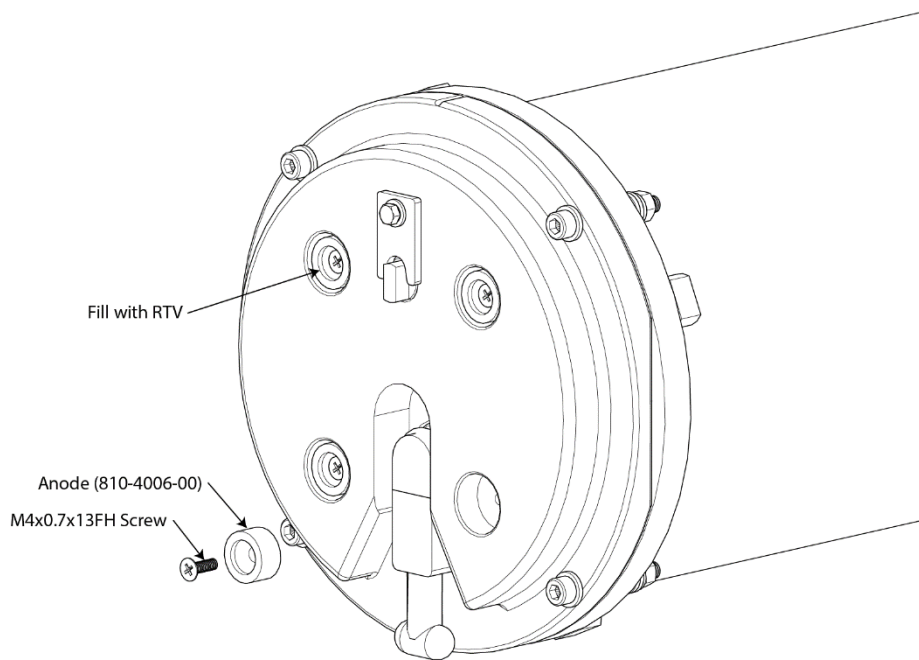

Figure 45. End-Cap Anodes

 The 810-4006 anodes are also used on the 3000 and 6000 meter housing.

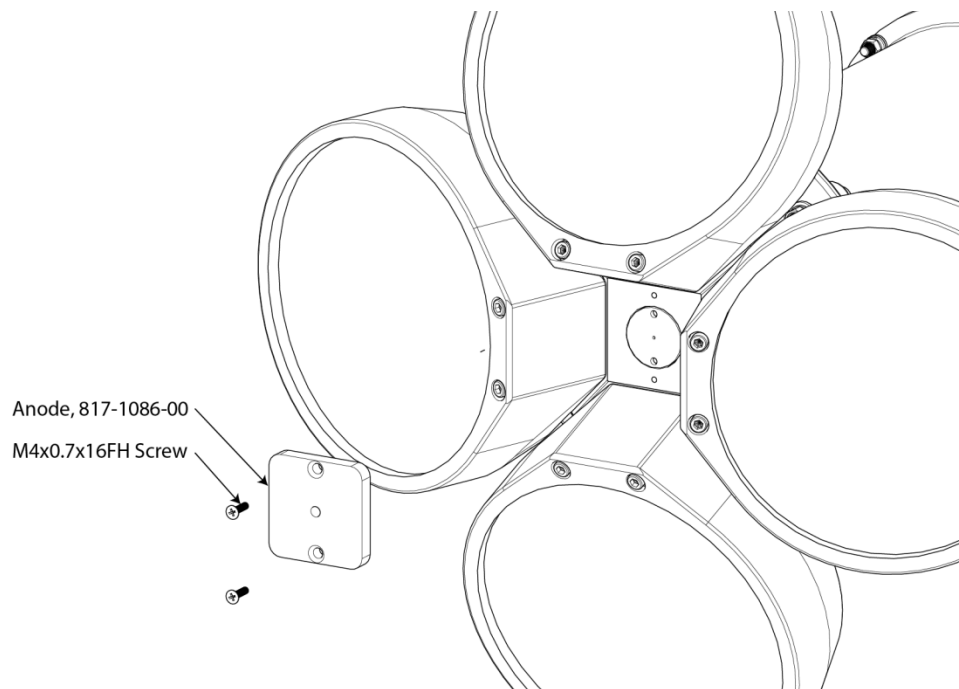

Figure 46. Transducer Anode



If you are replacing the transducer anode, see [Pressure Sensor Maintenance](#) before installing the new anode.

Preventing Biofouling

This section explains how to prevent the buildup of organic sea life (biofouling) on the transducer faces. Objects deployed within about 100 meters (≈ 328 feet) of the surface are subject to biofouling, especially in warm water. This means Long Ranger / QuarterMaster ADCP systems are subject to biofouling. Soft-bodied organisms usually cause no problems, but barnacles can cut through the urethane transducer face causing failure to the transducer and leakage into the ADCP. Therefore, you should take steps to prevent biofouling during shallow water deployments.

Some organizations may decide to use antifouling grease. However, most antifouling greases are toxic and may cause problems. Recent tests suggest antifouling grease may cause the urethane on the transducer faces to develop cracks. Warmer temperatures accelerate this effect. If using antifouling grease, remove the grease immediately after recovering the ADCP from its deployment. Remove the grease with soapy water because cleaning solvents may also cause the urethane to crack. Be sure to wear protective gloves and a face shield.

The best-known way to control biofouling is cleaning the ADCP transducer faces often. However, in many cases this is not possible.

The following options can help reduce biofouling:

- Coat the entire ADCP with antifouling paint. Make sure that the paint is applied in an even coat over the transducer faces and inductive modem (see [Applying Antifouling Paints](#)).
- Apply a thin coat (1 mm, 0.039 in.) of either a 50:50 mix of chili powder and petroleum jelly or chili powder and silicone grease to the transducer faces. The chili powder should be the hottest

that can be found. Water flowing across the transducers will wash this mix away over time. The silicone mixture tends to last longer.

- If using antifouling grease, remove the grease immediately after recovering the ADCP from its deployment. Remove the grease with soapy water. Be sure to wear protective gloves and a face shield.



If using antifouling grease, remove it immediately after recovering the ADCP.

Antifouling grease is toxic. Read the product safety data sheet before using the grease.

Wear gloves and a face shield when applying the grease. If the skin comes in contact with the grease, immediately wash the affected area with warm, soapy water.

All U.S. coastal states prohibit the use of tributyl-tins on boat hulls. The European Economic Commission has released a draft directive that would prohibit the use of many organo-tins after July 1989. TRDI strongly recommends you obey your local laws.

Antifouling Paints

You can use almost any EPA approved anti-fouling paint on the housing or the urethane transducer faces. Contact the antifouling paint manufacturer for preparation and application procedures for this and other antifouling paints. Interlux is one source of antifouling paint. Contacting this company is done with the knowledge that Teledyne RD Instruments is not recommending them, but only offering this as a source for the anti-fouling paint.

Manufacturer	Contact
Courtalds Finishes	Telephone: +1 (800) 468-7589
Interlux brand paints	Web Page : http://www.yachtpaint.com/usa/



Do not use antifouling paints that contain cuprous oxide on aluminum housings as it will cause galvanic corrosion.

Applying Antifouling Paints

The following tips are only general recommendations. Always follow the anti-fouling paint manufacturer's instructions on how to apply the anti-fouling paint.



TRDI recommends that any antifouling coating should be applied in as thin a layer as possible. It should be understood that applying a coating may reduce the measurement range of the ADCP (though it will not affect its accuracy in the measurable range).



As originally manufactured, the transducer faces have a smooth surface which makes it inhospitable for most biofouling to develop. Preserving this smooth surface is an effective way to prevent heavy biogrowth on the transducer faces. However, if an antifouling coating is desired on the transducer faces, then the faces must be lightly abraded to allow for the antifouling coating to adhere. As a rule, the surface must be kept smooth unless an antifouling coating will be applied.

1. Transducer Face Surface Preparation and painted housings - Lightly abrade the surface using Scotch Brite® to remove gloss. Thoroughly clean the areas to be painted with soapy water and dry.
2. Surface Application:
 - Mask as necessary. Do not paint over mounting hardware, anodes, pressure sensors, etc.
 - Apply an even, thin layer (0.1mm, 4 mil per coat) of antifouling paint. If more than one coat is needed to reach the maximum thickness, allow each coat to dry for 16 hours.

- When applying paint to the urethane faces, use extra caution to apply a smooth, thin coat of paint.

Removing Biofouling

To remove foreign matter and biofouling:

1. Remove soft-bodied marine growth or foreign matter with soapy water. Waterless hand cleaners remove most petroleum-based fouling.



Do not use power scrubbers, abrasive cleansers, scouring pads, high-pressure marine cleaning systems or brushes stiffer than hand cleaning brushes on the transducer faces. The urethane coating on the transducer faces could be damaged.

If there is heavy fouling or marine growth, the transducer faces may need a thorough cleaning to restore acoustic performance. Barnacles do not usually affect ADCP operation, but TRDI does recommend removal of the barnacles to prevent water leakage through the transducer face. Lime dissolving liquids such as Lime-Away® break down the shell-like parts. Scrubbing with a medium stiffness brush usually removes the soft-bodied parts. Do NOT use a brush stiffer than a hand cleaning brush. Scrubbing, alternated with soaking in Lime-Away®, effectively removes large barnacles.



If barnacles have entered more than 1.0 to 1.5 mm (0.06 in.) into the transducer face urethane, you should send the ADCP to TRDI for repair. If you do not think you can remove barnacles without damaging the transducer faces, contact TRDI.

2. Rinse with fresh water to remove soap or Lime-Away® residue.
3. Dry the transducer faces with low-pressure compressed air or soft lint-free towels.



Always dry the ADCP before placing it in the storage case to avoid fungus or mold growth. Do not store the ADCP in wet or damp locations.

Installing Firmware Upgrades

The firmware for Long Ranger / QuarterMaster ADCPs is located on flash RAM chips on the CPU board. Firmware upgrades can be downloaded from TRDI's website.



Teledyne RD Instruments Firmware, software, and Field Service Bulletins can be accessed only via our Customer Support Portal.

To register, please go to

<https://extranet.teledyne.com/layouts/15/Registration/registration.aspx?company=7> to set up your customer support account. After your account is approved, you will receive an e-mail with a link to set up your log in credentials to access the portal (this can take up to 24 hours).

Once you have secured an account, use <https://extranet.teledyne.com/sites/Marine/RDI> to access this data with your unique user name and password.

If you have an urgent need, please call our Technical Support hotline at +1-858-842-2700.

To install a firmware upgrade:

1. Connect your ADCP to the computer as shown in [Setting up the Long Ranger / QuarterMaster System](#).
2. Start the program *WHMSLxxx.exe* (where *xxx* is the firmware number).
3. Click **Setup**. Click the **View README.TXT** button to view the Readme.txt file for details on what is new in this version of the firmware.
4. Click **Next** and follow the on-screen prompts.
5. If you are not able to install the new firmware, contact Customer Service.
6. After successfully upgrading the firmware, use *TRDI Toolz* to test the ADCP (see [Testing the Long Ranger / QuarterMaster](#)).

Installing Feature Upgrades

The feature upgrade installation program is used to install Lowered ADCP (LADCP), High-Resolution Water-Profiling mode, High Ping Rate, and Waves capabilities in an ADCP.



The upgrade file is specific to the unit for which it was ordered. DO NOT attempt to install this feature for any other unit.



Many feature upgrades require the latest firmware version to be installed in your ADCP. If you need to update the firmware, do this before installing the feature upgrade (see [Firmware Upgrades](#)).

To install a feature upgrade:

1. Set up the Long Ranger / QuarterMaster as shown in [Setting up the Long Ranger / QuarterMaster System](#).
2. Start the program *Activate_WH_xxxx.exe* (where *xxxx* is the ADCP's serial number).
3. The installation program will start (see Figure 47). The program is encoded with the ADCP's serial number and the requested feature upgrade.

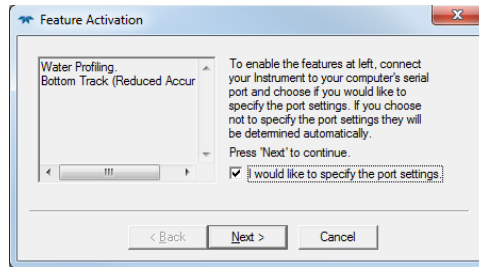
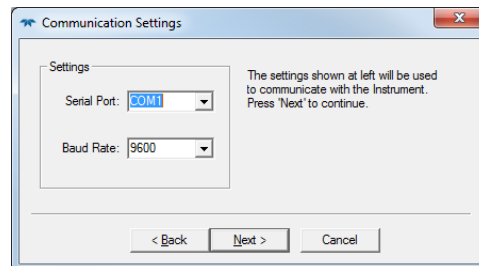

Figure 47. Installing Feature Upgrades

4. To select the port settings, select the **I would like to specify the port setting** box and click **Next**.



5. Select the **Serial Port** and **Baud Rate**.
6. Click **Next** to install the feature upgrade.
7. Click the **Finish** button to exit the program.
8. Start *TRDI Toolz* and use the OL command (see the WorkHorse Commands and Output Data Format guide) to verify the feature upgrade has been installed.

Maintenance Procedures

Use these procedures as needed.

Replacing the PC Card Recorder

The PC Card recorder is located on the Digital Signal Processor (DSP) board inside the Long Ranger / QuarterMaster's electronics (see Figure 48). Data can be recovered two ways.

- Download the data via the serial port using *WinSC* or *TRDI Toolz*.
- Remove the card from the Long Ranger / QuarterMaster and use a laptop computer to copy the data.

To remove or install a PC card:

1. Turn off power to the Long Ranger / QuarterMaster.
2. Remove the housing (see [Housing Assembly Removal](#)).
3. Remove the PC cards by pushing the button on the side of the PCMCIA card slot. The card should "pop" out of the connector. If you cannot reach the release button with your finger, use a plastic pen or non-conductive tool to depress the button. Do not try to force the card in or out of the connector. PC cards slide easily in or out when properly oriented.



Figure 48. PC Card Recorder Access Slot

4. When you are finished recovering the data, install the PC card back into the DSP board. PC cards install with the label side toward the face of the transducer.
5. Install the housing (see [Housing Assembly Replacement](#)).



Do not use a PCMCIA adapter for compact flash cards. These do not work.



Do not delete files from the PC card using Windows®. This may leave hidden files on the card. Always use the ADCP's erase command to delete data from the PC card recorder.

Replacing Fuses

There is one fuse on the end-cap that protects the Long Ranger / QuarterMaster from excessive incoming power. If this fuse continues to blow, check your input power before applying power again.

To replace the fuse:

1. Turn off the power.
2. Remove the end-cap (see [End-Cap Removal Procedures](#)).
3. The fuse is located on the bottom of the end-cap (Figure 49). Use a small flat-blade screwdriver to open the fuse housing. Turn the end 180° counter-clockwise to open the fuse housing.
4. Gently pull the fuse housing out. Turn the housing to remove the fuse.
5. Replace the fuse with the correct voltage and amperage fuse (Table 1).
6. Install the end-cap (see [End-Cap Replacement](#)).
7. Test the system (see [Testing the Long Ranger / QuarterMaster](#)).

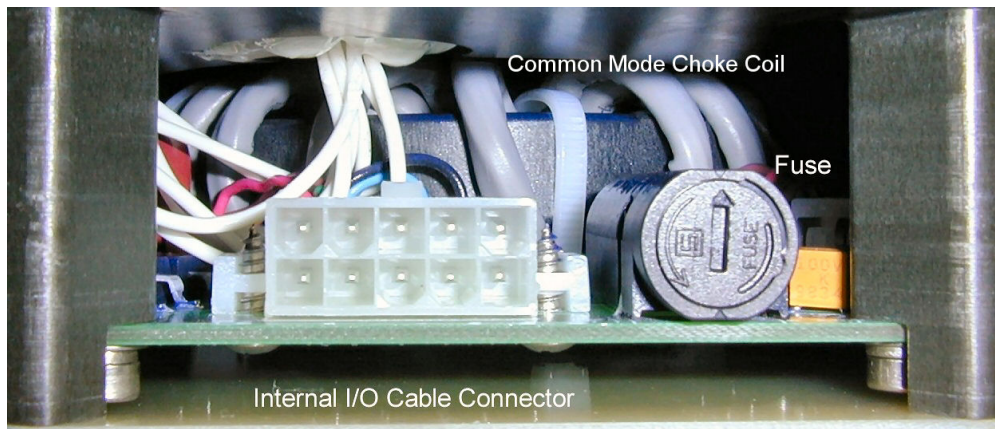

Figure 49. Fuse

Changing Communications Setting

Use the switch on the high power I/O board (see Figure 50) to change the communication settings between RS-232 and RS-422. Your computer and the Long Ranger / QuarterMaster must both be set to the same communication setting. Use a RS-232-to-RS-422 converter if the Long Ranger / QuarterMaster is using RS-422 communications and your computer only has an RS-232 COM port.

To change the communication setting:

1. Turn off power to the Long Ranger / QuarterMaster.
2. Remove the housing (see [Housing Assembly Removal](#)).
3. Change the switch setting as needed.
4. Install the housing (see [Housing Assembly Replacement](#)).



Figure 50. Communication Setting Switch



The default setting is RS-232.

Installing the Spare Boards Kit

The Spare Boards Kit has been setup so that you will replace the High Power I/O, CPU, and DSP boards as a set (see **Error! Reference source not found.** for board locations). This is done so that you do not have to risk damaging the individual boards while swapping in individual boards. The heading, pitch, and roll sensors have all been calibrated (the temperature sensor is an independent calibration and not changed by these new boards). Once you have replaced your original boards, place them back in the Spare Board Kit box and contact Teledyne RD Instruments Customer Service Department so that you can return them for repair.



Before handling either the Spare Board Kit or the original Board Set, always wear an earth-grounding static protection strap. The electronics in the Long Ranger / QuarterMaster are very sensitive to static discharge. Static discharge can cause damage that will not be seen immediately and will result in early failure of electronic components.

TRDI assumes that a qualified technician or equivalent will perform all of the following work.



The High Power Amplifier Assembly, Tuning, and Receiver boards are not included in the Spare Board kit.



The Spare Boards kit is not included with the system. You can order the kit by contacting Teledyne RD Instruments Customer Service department (see [Technical Support](#)).

The Spare Boards Set will allow your system to perform to the same velocity specifications as your original set. However, there is an offset error in the compass that can be as great as ± 1.5 degrees. This error CANNOT be removed by doing the Field Calibration procedure (AF command) even though you MUST do this as part of the installation. The additional ± 1.5 degrees can only be removed by TRDI at the factory. In most cases, the total compass error will still be within our original specification of ± 5.0 degrees. The only way to be sure that you have smaller errors than this specification is to perform your own local compass verification and correct any errors you find during post processing of the data.

Removing the Original Set of Boards

To remove the original boards:

1. Remove the housing assembly (see [Housing Assembly Removal](#)).
2. With your earth-ground static protection strap on, use a 3 mm Allen wrench to remove the four bolts that secure the High Power Amplifier Assembly to the shield.
3. Tilt the High Power Amplifier Assembly up enough to disconnect the I/O and Transmit cables. Set the High Power Amplifier Assembly aside.
4. Use a 3 mm Allen wrench to remove the four bolts that secure the board stack to the transducer assembly.
5. Once the screws have been removed, place a finger on each side, under the bottom of the board stack of the board stack and remove the three boards as a set by lifting them straight up.



These three boards are connected to each other via connectors and will remain as one piece.

6. Remove all PCMCIA card(s) from the original set of boards. These PCMCIA cards will be used again once you install your Spare Boards Set. The Spare Board set does NOT contain a PCMCIA card(s). The PCMCIA card(s) are located on the DSP board. To remove the PCMCIA card(s) press the button(s) on the side of the PCMCIA card slot. As you press this button the PCMCIA card will slide out. You will have to pull the card(s) out the rest of the way once the button is depressed all the way in.
7. Set the original board set to the side for now.

Installing the Spare Board Kit

To install the spare boards kit:

1. With your earth-ground static protection strap on, remove the Spare Board Kit from the anti-static bag.
2. Using a 3 mm Allen wrench and a 7 mm wrench remove the nuts from the bolts that secure the Spare Boards together. You will be using these bolts to secure the spare set in your system.
3. Place the nuts (just removed) on the four bolts of your original set of boards and place them into the anti-static bag. You will use the new set of bolts included in the Spare Board kit to secure them to the Transducer assembly.



DO NOT change the position of any of the bolts. The bolt containing the ground jumper must remain in the same position (see Figure 51 for board locations).

4. Install all PCMCIA cards removed in [Remove the Original Set of Boards step 5](#) into the PCMCIA card slots. The PCMCIA card is keyed and will only connect when it has been aligned correctly and slid all the way in. The PCMCIA card is installed with the label side pointing away from the DSP board.
5. Connect the new Spare Board set to the Receiver board. Align the Spare Board set to the header to the Receiver board.
6. Apply one drop of thread locker to each bolt. Insert the four new bolts and tighten to 0.67 Nm (6 Pound-Force Inch).
7. Connect the transmit cable you removed in [Remove the Original Set of Boards step 3](#) to the High Power Amplifier Assembly. The connector is keyed so it will only connect in the proper orientation.



Make sure to tuck the transmit cable inside the shield. If the cable pokes out, it will be cut/pinched when the housing is replaced.

8. Connect the I/O cable from the High Power Amplifier Assembly to the connector on the High Power I/O board.
9. Install the screws holding the High Power Amplifier Assembly to the shield and tighten to 0.67 Nm (6 Pound-Force Inch).
10. Install the housing (see [Housing Assembly Replacement](#)).

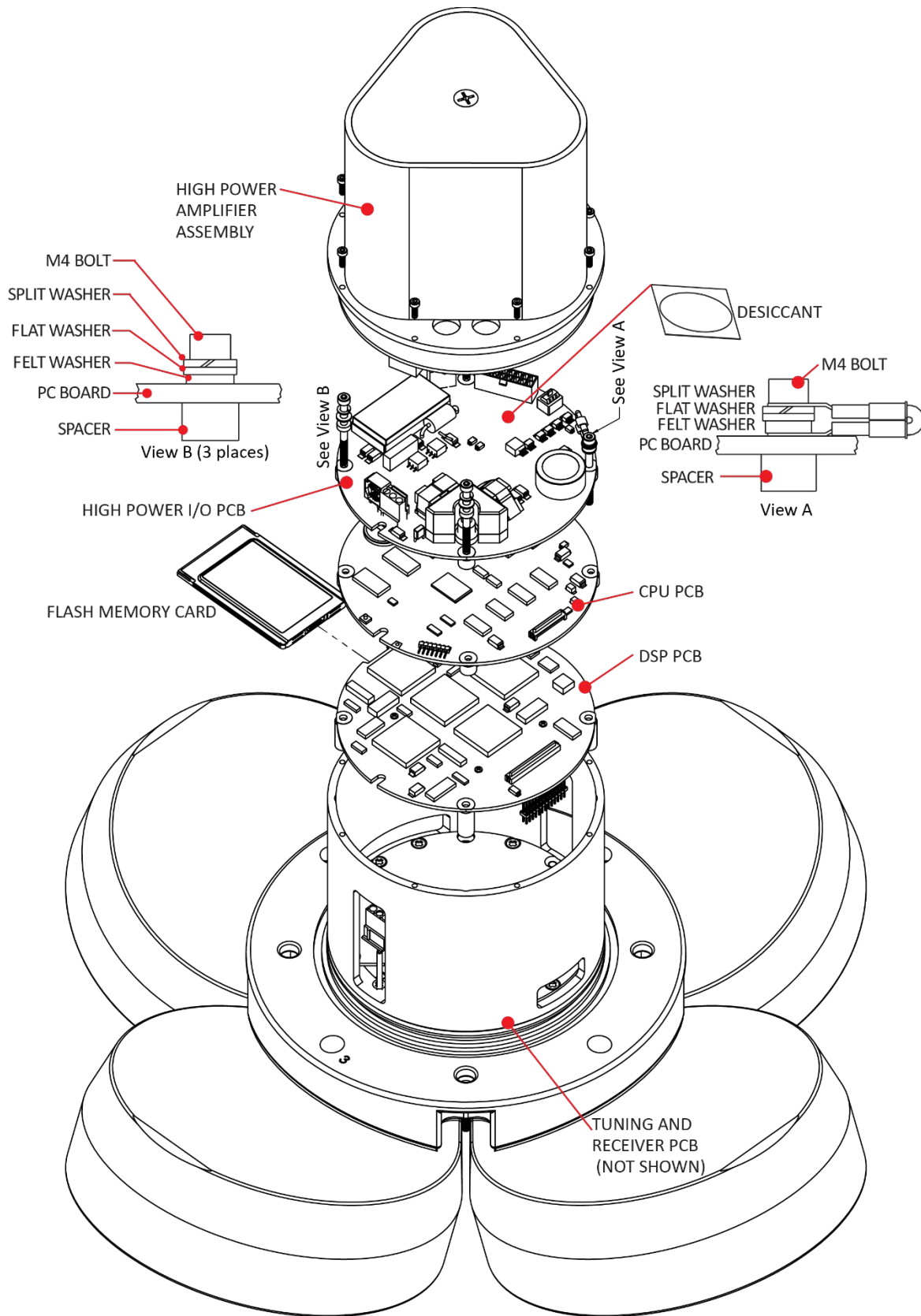

Figure 51. Installing the Spare Boards Kit

Installing the Beam Cosine Matrix

The beam cosine matrix table corrects small transducer beam misalignment angles that occur during manufacturing.

To install the beam cosine matrix:

1. Connect your Long Ranger / QuarterMaster ADCP as you would normally and apply power.
2. Start *TRDI Toolz* and confirm that the Long Ranger / QuarterMaster ADCP is communicating normally and which communication port you are using (COM 1 or COM 2).
3. Place the Beam Cosine Matrix Disk into your computer's disk drive.
4. If your ADCP is connected to COM 1, press <F2> and run the script file *xxxx_1.scr* (where xxxx is your system serial number).

If your ADCP is connected to COM 2, press <F2> and run the script file *xxxx_2.scr* (where xxxx is your system serial number).

Your Beam Cosine Matrix table will automatically be updated in your ADCP and a file called *SPRBD.LOG* will be created. You can view the contents of this file to confirm that the data entered during the &V portion matches the contents in the PS3 results under the label Q14.

Testing the System after Replacing Boards

To test the system after replace any board(s):

1. Install the housing (see [Housing Assembly Replacement](#)).
2. Connect the cable and power as you normally do and test the ADCP as shown in [Testing the Long Ranger / QuarterMaster](#). All PA tests should pass when run in water and the PC tests should pass with the ADCP out of water.

To test that the transmit cable is connected properly, start *TRDI Toolz* and run the PT4 test. The test failure example shown below is what you would see for a missing or improperly attached transmit cable.

```
>pt4
IXMT    =      0.0 Amps rms  [Data= 0h]
VXMT    =     19.3 Volts rms [Data=4ch]
Z       =     999.9 Ohms
Transmit Test Results = $C0 ... FAIL
>
```

3. Perform a field calibration of your compass. Use [Compass Calibration](#) for instructions on running the AF command. Remember that there will be up to 1.5 degrees of offset error in the compass measurement. This error is not removed by the field calibration.

You have completed the Long Ranger / QuarterMaster Spare Board Installation. The original boards can be returned to TRDI for repair. Please contact the Teledyne RD Instruments Customer Service Department for return shipping instructions and repair costs (see [Technical Support](#)).

Long Ranger / QuarterMaster Conversions

Use the following procedures and Figure 52 to change the Long Ranger / QuarterMaster between a Self-Contained and Direct Reading system. See the [Parts Location Drawings](#) for reference.

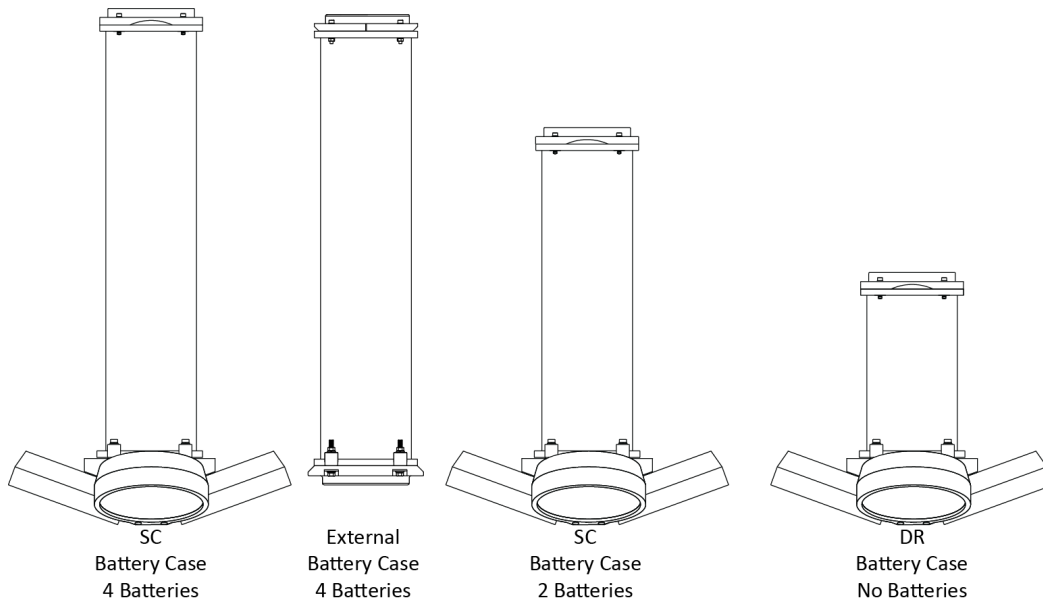

Figure 52. Long Ranger / QuarterMaster Configurations



The Remote Head configuration includes a Direct-Reading Long Ranger / QuarterMaster and an external battery case.

Converting from Self-Contained to Direct-Reading

To convert the standard Self-Contained system to the Direct-Reading configuration:

1. Remove the end-cap from the Self-Contained housing (see [End-Cap Removal Procedures](#)).
2. Remove the battery modules (see [Battery Pack Module Removal](#)).
3. Remove the Self-Contained housing (see [Housing Assembly Removal](#)). Do not remove the internal I/O cable from the housing (see next step).
4. Connect the new short internal I/O cable to the High Power Amplifier assembly. Attach the lanyard to the assembly.
5. Install the Direct-Reading housing (see [Housing Assembly Replacement](#)).
6. Attach the lanyard to the end-cap assembly. Install the end-cap (see [End-Cap Replacement](#)).

Converting from Direct-Reading to Self-Contained

To convert the Direct-Reading system to the Self-Contained configuration:

1. Remove the end-cap from the Direct-Reading housing (see [End-Cap Removal Procedures](#)).
2. Remove the Direct-Reading housing (see [Housing Assembly Removal](#)).
3. Disconnect and remove the short internal I/O cable and lanyard from the Hi Power Amplifier assembly.

4. Connect the long internal I/O cable to the High Power Amplifier assembly. Attach the lanyard to the assembly. Install the Self-Contained housing (see [Housing Assembly Replacement](#)).
5. Attach the lanyard to the end-cap assembly. Plug in the internal I/O cable to the end-cap connector. Install the batteries and end-cap.

Converting a SC Housing to an External Battery Case

To convert the Self-Contained housing to an External Battery Case:

1. Connect the internal I/O cable to the new transducer side end-cap and install the transducer side end-cap (see [End-Cap Replacement](#)).



There is no lanyard connection on this end of the cable. Do not suspend the transducer side end-cap by the I/O cable.



The transducer side end-cap uses the L-bushings to attach the end-cap to the housing. Once this end-cap is installed, there is no need to remove it. The batteries can not be accessed from this end of the housing.

2. Insert the battery modules (see [Battery Pack Module Replacement](#)).
3. Attach the lanyard to the battery side end-cap assembly and install the end-cap (see [End-Cap Replacement](#)).



The external battery case, battery side end-cap is different than the standard Long Ranger / QuarterMaster end-cap. Figure 49 shows the standard Long Ranger / QuarterMaster end-cap. The common mode choke coil is very visible behind the internal I/O cable connector and fuse. The common mode choke coil is NOT installed on the battery side end-cap.



Do not swap end-caps between the external battery case and the standard Long Ranger / QuarterMaster end-cap.

4. Place the dummy plug on the battery side end-cap.
5. Connect the extension cable from the transducer side end-cap to the Direct-Reading Long Ranger / QuarterMaster.



The external battery case connector is always “hot” when batteries are installed. When you connect the cable with power applied, you may see a small spark.



The external battery case should not be connected or disconnected underwater. The electrical output power will degrade the connector contacts and present a **potential electrical shock hazard to installation personnel when the power connector is short-circuited in water. The external battery case output power cannot be enabled or disabled underwater.**

Replacing the End Cap Connector

This section explains how to replace the 7-pin end-cap connector on a Long Ranger / QuarterMaster or external battery.



Some older Long Ranger / QuarterMaster end-caps may have the connector brass lock nut glued in to place. If this is the case for your end-cap assembly, TRDI recommends that you purchase a new end cap assembly.

Equipment Provided

The WorkHorse End-Cap Tools Kit (P/N 757K6122-00) includes the following:

- Socket, lock nut removal
- Extracting wrench
- Plug, dummy, modified



The End Cap Replacement Kit 757K6129-00 (Long Ranger / QuarterMaster) includes the following:

- 7-pin end-cap connector with cable and 2-014 O-ring
- Isolation bushing and 2-017 O-ring (metal end-caps only)
- Connector, header, 8-pin Molex or 2-pin as needed
- Fuses and fuse holders, wire, shrink tube (External Battery kit only)
- Nut, brass
- End-cap O-ring(s)
- Desiccant
- Silicon lubricant, 4-pack
- Loctite® 242
- Cord, lacing, black

Customer Supplied Additional Equipment

- Soft pad (ESD Safe) to rest Long Ranger / QuarterMaster on while disassembling and reassembly
- Socket wrench handle
- Torque Wrench (35 Inch/pound / 4 N-M)
- Multi-Meter

Removing the End-Cap Connector

To remove the end-cap connector:

1. [Remove the end-cap](#) from the housing.
2. Remove the cover plate and End-Cap Interface board from the end-cap. See Figure 58 for details.
3. Insert the modified dummy plug into the connector.



Figure 53. Modified Dummy Plug

4. Place the Extracting Wrench over the connector and dummy plug. The wrench will fit into the End Cap slot.

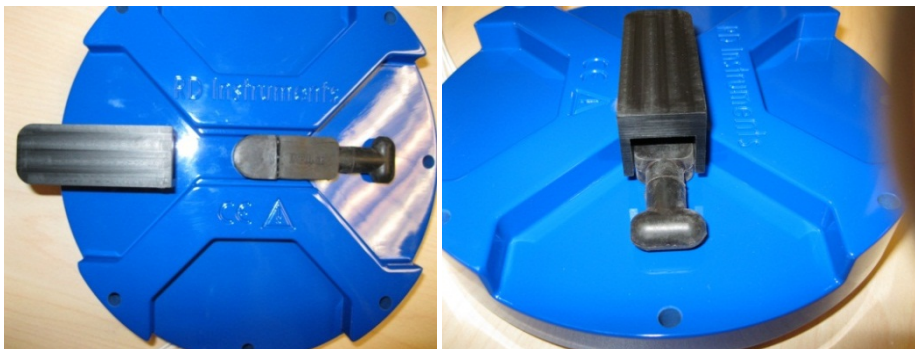

Figure 54. Extracting Wrench

5. Flip the end-cap assembly over and insert the socket onto the lock nut. Slide the cable wires into the socket's clearance slot.

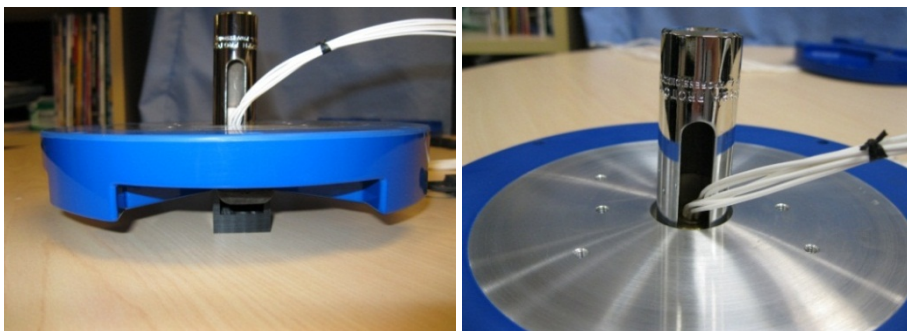

Figure 55. Lock Nut Removal Socket

6. Attach a ratchet wrench to the socket and remove the locknut.



Figure 56. Removing the Connector

7. Remove the Molex 8-pin header connector by cutting the wires approximately 3-inches from the connector. Remove the connector from the end-cap.



USE CAUTION – do not score or scratch the O-ring seal bore.

8. Remove all the tools and clean the end-cap thoroughly with Flux-Off® cleaner (or similar product). The O-ring pocket must be free of dirt, burrs and divots.



Replace the end cap if any burrs or divots are found. These could provide a leakage path into the ADCP housing.

Installing the New End-Cap Connector

To install the new connector:

1. Clean the connector threads with Flux-Off® cleaner (or similar product).
2. Apply a **light** coat of silicon lubricant onto the O-rings (P/N 2-014 and 2-017).



Do not over lube the O-rings.

3. Systems with a metal end-cap use an isolation bushing and 2-017 O-ring between the end-cap and the 7-pin connector. Press the new bushing and O-ring onto the end-cap as shown in Figure 57.



Carefully check metal end-caps for signs of corrosion such as white deposits. If corrosion caused part of the end-cap to be visibly damaged, do not redeploy your system. Send it back to TRDI for inspection.

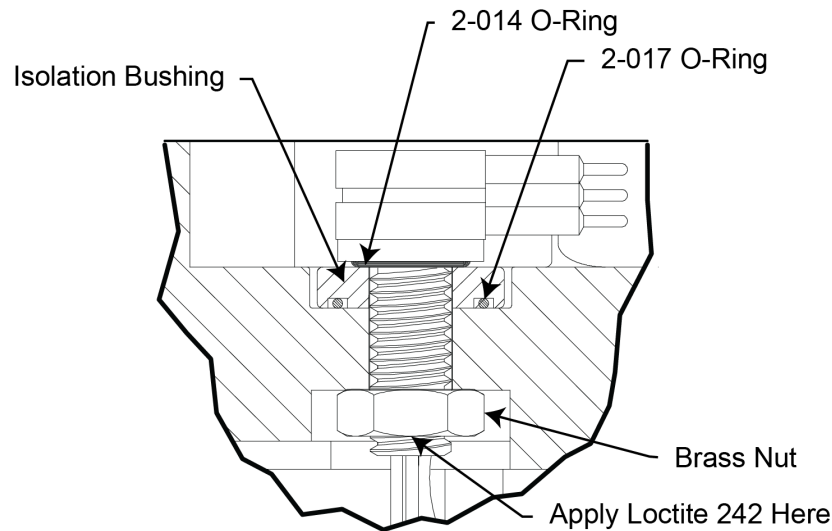

Figure 57. End-Cap Connector with Isolation Bushing

4. Install the O-ring onto the face seal groove located at the bottom of the threads on the connector.



Do not scratch or mar the O-ring surface as you feed it over the threads of the connector.

5. Install the modified dummy plug. Pay attention to the pin orientation. **Do not bend the pins.**
6. Apply one drop of Loctite® 242 on the top starting threads of the connector.
7. Install the connector into the end cap by feeding the 7 wires and pins through the end-cap from the outside face (see Figure 53).



The connector pins should point away from beam 3.

8. Push the connector down so that it fully bottoms out in the O-ring pocket.



Do not score or scratch the bore or the O-ring pocket sealing face.

9. Feed the brass nut through the wires and pins and hand tighten onto the connector threads.
10. Place the Extracting Wrench over the connector and dummy plug. The wrench will fit into the End Cap slot between the 2 rails (see Figure 54).
11. Flip the End-Cap assembly over and insert the slotted socket onto the lock nut. Fit the cable wires into the socket's clearance slot (see Figure 55).
12. Attach a torque ratchet wrench to the socket and tighten the nut to 35 in/lbs., (4 NM). **Make sure that the connector is aligned straight and is parallel to the rails.**
13. Remove the assembly tools and the dummy plug.
14. Follow the wiring schematic in order to assemble the Molex 8-pin header connector or external battery case wiring (see [Wiring Diagrams](#)). Insert the pins into the connector. As the pin is pushed into the connector, the tabs on the pin will lock it into place.



Use the old cut-off Molex connector as a reference in addition to the schematic diagram when installing the new Molex connector. Each wire should have a corresponding J1 pin number tag.

15. After all the pins for the connector are installed, use a multi-meter to confirm that the connector has been wired properly by performing an end-to-end continuity check.
16. Use the black lacing cord to bind the connector wires together. The lacing is applied by wrapping it around the wire bundle approximately four times and then tying it securely with a square knot. Each wrap on the wire bundle should be spaced approximately 3-inches apart. This will prevent the wires from “bird caging” out and getting caught between the end-cap and pressure case O-ring.
17. Replace the End-Cap Interface board and cover (see Figure 58). Install the end-cap. Use new end-cap O-rings and desiccant before sealing the ADCP.

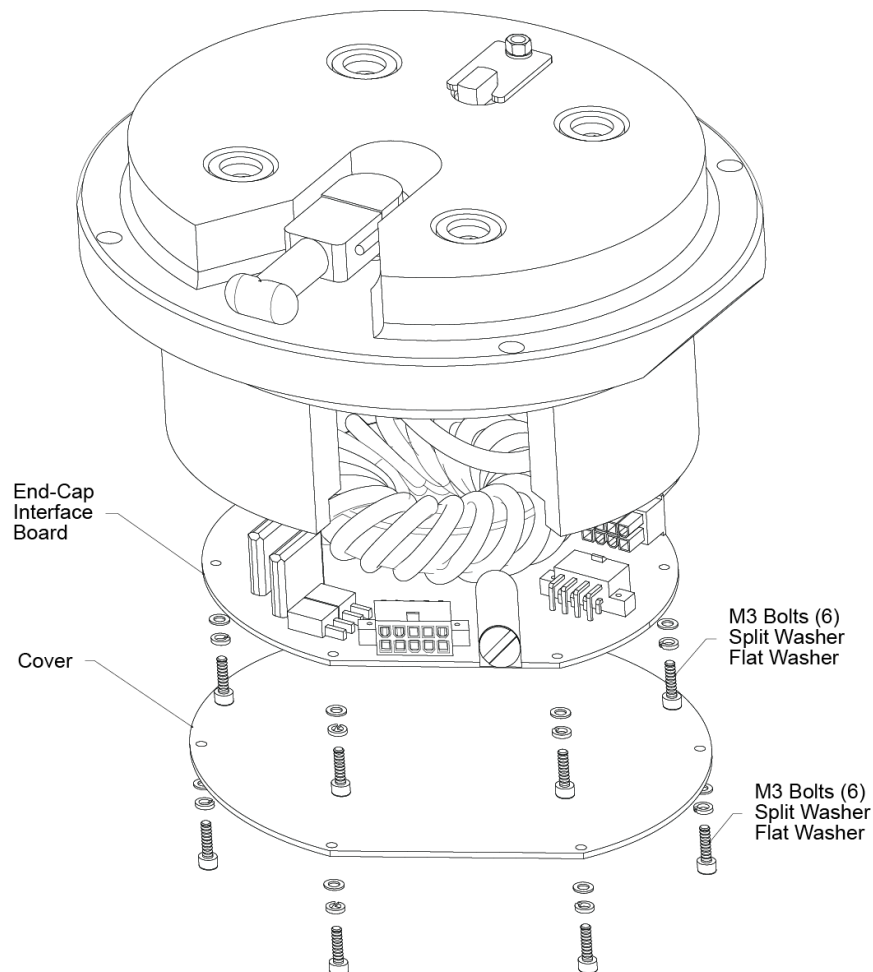

Figure 58. Long Ranger / QuarterMaster End-Cap Assembly

Wiring Diagram

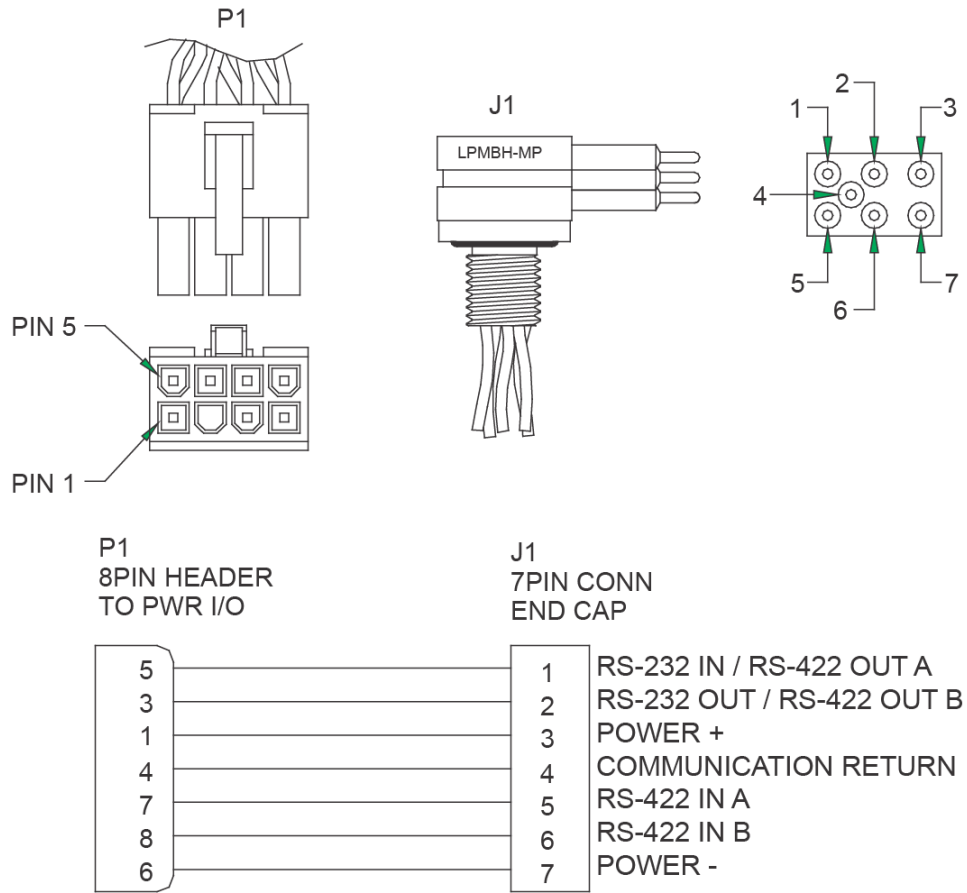

Figure 59. End-Cap Connector Wiring – Long Ranger / QuarterMaster ADCP

Replacing the CPU Lithium Battery

This section explains how to replace the rechargeable lithium coin-cell battery in a Long Ranger / QuarterMaster system. The battery is located on the CPU board just below the PIO board transmit capacitors. The battery will recharge itself as soon as power is applied to the ADCP. Over time, the battery loses the ability to recharge and the voltage capacity drops. Therefore, TRDI recommends replacing the battery every five years.



The battery keeps the Real-Time Clock (RTC) running in case power is removed temporarily. The RTC drifts independently from the battery voltage by approximately 12 minutes/year. Clock drift does NOT indicate problems with the battery.

Equipment Required

- ESD safe work space
- Soft pad (ESD Safe) to rest WorkHorse on while disassembling and reassembly
- Anti-static ground strap
- Hex wrenches
- O-rings and desiccant for ADCP
- Soldering iron
- Digital multi-meter
- Lithium battery VL2330

To check for a failing lithium battery:

1. Charge the lithium battery by powering the system using external power and use *TRDI Toolz* to send the PC2 command to prevent the ADCP from sleeping. Let the system run for three hours.
2. Send the TS command and set the clock.
3. Remove all power to the system and wait at least 6 hours (two days is recommended). If you don't want to wait several days, [remove the transducer head assembly](#). On the PIO board short TP10 (GND) to TP11 (VDD2) for 10 seconds using a jumper wire. Remove the jumper.
4. Power up the system and send the TS? command to verify the system time. If the time has reset to January 1, 2000 or is significantly incorrect, then you should verify the lithium battery voltage.

Testing the CPU Lithium Battery Voltage

To verify that the lithium battery voltage:

1. Charge the battery by powering the system using external power and send the PC2 command to prevent the ADCP from sleeping. Let the system run for three hours.
2. Remove all power from the ADCP. [Remove the transducer head assembly](#).



Wait a few minutes after turning the power off before removing the electronics stack. This allows the transmit capacitors on the PIO board time to discharge.

3. Attach an earth-grounded wrist strap.



Before handling any of the WorkHorse boards, you must be sure that you always wear an earth-grounding static protection strap. The electronics in the WorkHorse are very sensitive to electro-static discharge (ESD). ESD can cause damage that will not be seen immediately and will result in early failure of electronic components.

4. Remove the CPU board from the main electronic stack (see [Installing the Spare Boards Kit](#)).
5. Measure the voltage on the CPU board between TP17 (BAT+) and the small pin on the battery located on the back side of the CPU board (GND) (see Figure 60).

6. The voltage should hold stable at approximately 2 to 3 VDC for several hours at least, but for best results it should hold at 3 VDC for several days.
7. If the voltage is not holding for more than a week, then the battery may be defective. Before continuing, review your options:
 - Replace the Lithium battery yourself.
 - If you are uncomfortable with replacing the battery, please contact [TRDI Customer Service Administration](#) to schedule a replacement of the battery or request a Return Merchandise Authorization (RMA) directly from our website <[here](#)>.

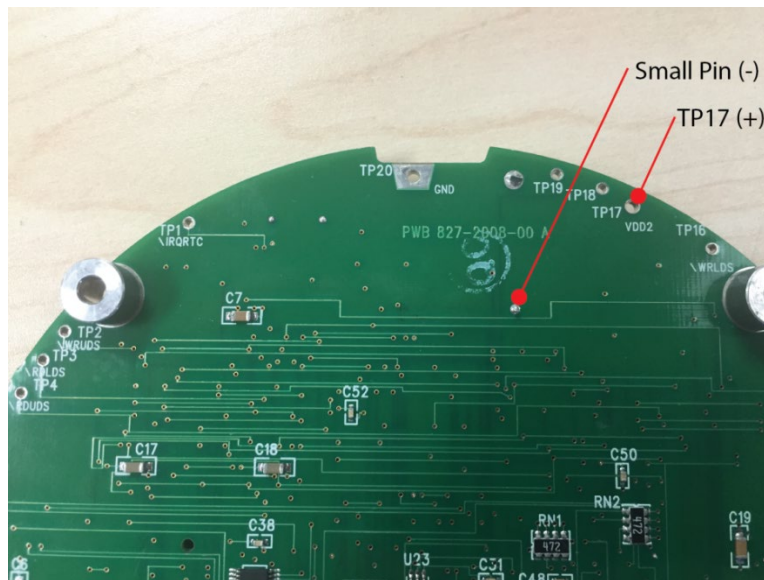

Figure 60. Lithium Battery Test Points on the CPU Board

Replacing the CPU Lithium Battery

To replace the battery:

1. While wearing an earth-grounded wrist strap, locate the lithium battery B1 (on the top side of the CPU board).
2. De-solder the two associated pins for B1 which are located on the underside of the CPU board.
3. Install the new battery assembly (VL2330). Please note the battery pins; the battery can only be installed one way.



Figure 61. Lithium Battery

4. Verify the voltage holds stable at approximately 3 VDC (see [Testing the Lithium Battery Voltage](#), step 2).
5. [Replace the transducer head assembly](#). Make sure to use new O-rings and desiccant.

Chapter 5

TESTING THE LONG RANGER



In this chapter, you will learn:

- Testing the Long Ranger with *WinSC*
- Testing the Long Ranger with *BBTalk*
- Test Results

This chapter explains how to test the Long Ranger / QuarterMaster using the *WinSC* and *TRDI Toolz* programs. These tests thoroughly check the Long Ranger / QuarterMaster in a laboratory environment, but are no substitute for a practice deployment. You should test the Long Ranger / QuarterMaster:

- When you first receive the Long Ranger / QuarterMaster.
- Before each deployment or every six months.
- When you suspect instrument problems.
- After each deployment.

These test procedures assume all equipment is working. The tests can help you isolate problems to a major functional area of the Long Ranger / QuarterMaster. For troubleshooting information, see [Troubleshooting](#).

Testing the ADCP with *WinSC*

To test the ADCP:

1. Connect and power up the ADCP as shown in [Setting up the Long Ranger / QuarterMaster System](#).
2. Start *WinSC* (for help on using *WinSC*, see the *WinSC* User's Guide).
3. At the **Welcome** screen, click **Test an ADCP**. Click **OK**. This will run the pre-deployment tests Deploy?, System?, TS?, PSo, PA, PC2, RS, and PC1-commands. The [results](#) of the tests will be displayed on screen and saved to the log file (*.scl).

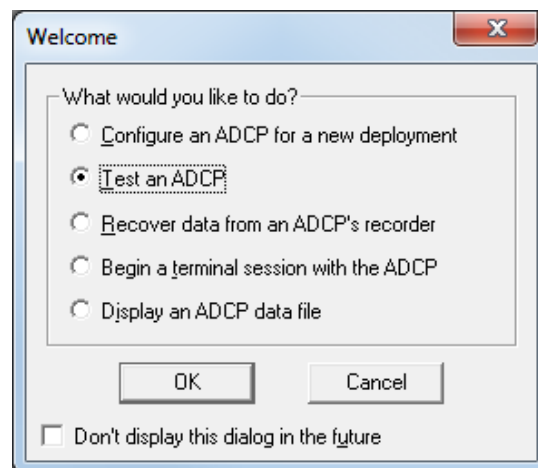
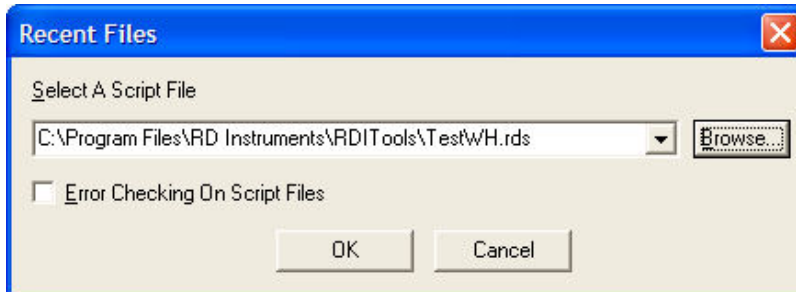

Figure 62. Using WinSC to Test an ADCP

Testing the ADCP with *TRDI Toolz*

To test the ADCP:

1. Interconnect and apply power to the system as described in [Setting up the Long Ranger / Quarter-Master System](#).
2. Start the *TRDI Toolz* program (for help on using *TRDI Toolz*, see the *TRDI Toolz User's Guide*).
3. Press <F2> and run the script file *TestWH.rds*. The *TestWH.rds* script file runs PSo, PS3, PA, PC2, and the PC1 tests. The results of the tests will be displayed and saved to the log file *WH_RSLTS.txt*.



Windows 7® will save the log file to:

C:\Users\username\AppData\Local\VirtualStore\Program Files (x86)\RD Instruments\TRDI Toolz.

Using Windows XP®, the *TRDI Toolz* program saves the test results file to different locations based on how the program was started. When you start *TRDI Toolz* from the desktop icon and run the test script file, the result log file is created on the desktop. If you run *TRDI Toolz* from the start menu, the results file is put in *C:\Documents and Settings\All Users\Start Menu\Programs\RD Instruments\TRDI Toolz*. It is only when you double-click the *.rds file in the TRDI Toolz folder that the results are saved to the TRDI Toolz folder.

To make sure the result file is always saved to the same location, see the *TRDI Toolz User's Guide* for instructions.

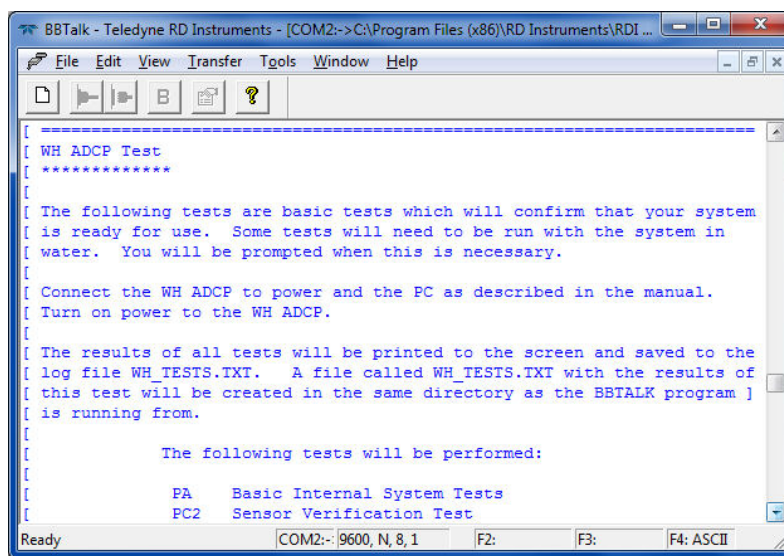

Figure 63. Using TRDI Toolz to Test an ADCP

Test Results

This section shows an example of the test result printout after running the *WinSC* tests or the *TRDI Toolz* script file TestWH.rds.



The built-in tests require you to immerse the transducer faces in water. If you do not, some of the tests may fail. Running the tests in air will not harm the ADCP.

Deploy Commands List

WinSC sends the ADCP the Deploy? command. This will show a list of the deployment commands and their current setting. For example;

```

deploy?
Deployment Commands:
RE ----- Recorder ErAsE
RN ----- Set Deployment Name

WD = 111 100 000 ----- Data Out (Vel,Cor,Amp; PG,St,P0; P1,P2,P3)
WF = 0088 ----- Blank After Transmit (cm)
WN = 030 ----- Number of depth cells (1-128)
WP = 00045 ----- Pings per Ensemble (0-16384)
WS = 0200 ----- Depth Cell Size (cm)
WV = 175 ----- Mode 1 Ambiguity Vel (cm/s radial)

BP = 000 ----- Bottom Track Pings per Ensemble

TE = 01:00:00.00 ----- Time per Ensemble (hrs:min:sec.sec/100)
TF = **/**/**,**:***:*** --- Time of First Ping (yr/mon/day,hour:min:sec)
TP = 01:20.00 ----- Time per Ping (min:sec.sec/100)
TS = 94/01/30,00:11:17 --- Time Set (yr/mon/day,hour:min:sec)

EA = +00000 ----- Heading Alignment (1/100 deg)
EB = +00000 ----- Heading Bias (1/100 deg)
ED = 00000 ----- Transducer Depth (0 - 65535 dm)
ES = 35 ----- Salinity (0-40 pp thousand)
EX = 11111 ----- Coord Transform (Xform: Type,Tilts,3 Bm,Map)
EZ = 1111101 ----- Sensor Source (C,D,H,P,R,S,T)

CF = 11111 ----- Flow Ctrl (EnsCyc;PngCyc;Binry;Ser;Rec)
CK ----- Keep Parameters as USER Defaults
CR # ----- Retrieve Parameters (0 = USER, 1 = FACTORY)
CS ----- Start Deployment

```

System Commands List

WinSC sends the ADCP the System? command. This will show a list of the system commands and their current setting. For example;

```
>system?
System Control, Data Recovery and Testing Commands:
AC ----- Output Active Fluxgate & Tilt Calibration data
AF ----- Field calibrate to remove hard/soft iron error
AR ----- Restore factory fluxgate calibration data
AX ----- Examine compass performance
AZ ----- Zero pressure reading

CB = 411 ----- Serial Port Control (Baud; Par; Stop)
CP # ----- Polled Mode (0 = NORMAL, 1 = POLLED)
CZ ----- Power Down Instrument

FC ----- Clear Fault Log
FD ----- Display Fault Log

OL ----- Display Features List

PA ----- Pre-Deployment Tests
PC1 ----- Beam Continuity
PC2 ----- Sensor Data
PS0 ----- System Configuration
PS3 ----- Transformation Matrices

RR ----- Recorder Directory
RF ----- Recorder Space used/free (bytes)
RY ----- Upload Recorder Files to Host
```

Time Set

WinSC sends the ADCP the TS? command. This will show the current setting of the real time clock. For example;

```
>TS?
TS = 12/06/17,07:31:27 --- Time Set (yr/mon/day,hour:min:sec)
>
```

Recorder Free Space

WinSC sends the ADCP the RS command. This will show the amount of used and free recorder space in megabytes. For example;

```
>RS
RS = 000,010 ----- REC SPACE USED (MB), FREE (MB)
>
```

Display System Parameters

This tells the ADCP to display specific information about your ADCP. Both *WinSC* and *TRDI Toolz* run this test. For example:

```
>ps0
>ps0
Instrument S/N: 1701
Frequency: 78800 HZ
Configuration: 4 BEAM, JANUS
Match Layer: 10
Beam Angle: 20 DEGREES
Beam Pattern: CONVEX
Orientation: DOWN
Sensor(s): HEADING TILT 1 TILT 2 DEPTH TEMPERATURE PRESSURE
Pressure Sens Coefficients:
c3 = +0.000000E+00
c2 = +0.000000E+00
c1 = -2.500000E-03
Offset = +0.000000E+00

Temp Sens Offset: -0.20 degrees C

CPU Firmware: 16.21
Boot Code Ver: Required: 1.13 Actual: 1.13
DEM0D #1 Ver: ad48, Type: 1f
DEM0D #2 Ver: ad48, Type: 1f
PWRTIMG Ver: 85d3, Type: 6

Board Serial Number Data:
97 00 00 02 C9 2B 84 09 DSP727-2001-02F
80 00 00 00 86 A4 15 09 Not Programmed
6F 00 00 02 FB B2 55 09 CPU727-2000-00H
F0 00 00 00 9A 99 B7 09 PIO727-3000-04C
>
```

Verify the information is consistent with what you know about the configuration of your system. If *PS0* does *not* list all your sensors, there is a problem with either the communications to the transducer or a problem with the receiver board.

Instrument Transformation Matrix

PS3 sends information about the transducer beams. Only the *TRDI Toolz* script file *TestWH.rds* runs this test. The Long Ranger / QuarterMaster uses this information in its coordinate-transformation calculations; for example, the output may look like this:

```
ps3
Beam Width: 3.7 degrees

Beam      Elevation      Azimuth
1         -70.14          269.72
2         -70.10          89.72
3         -69.99          0.28
4         -70.01          180.28

Beam Directional Matrix (Down):
0.3399    0.0017    0.9405    0.2414
-0.3405   -0.0017    0.9403    0.2410
-0.0017   -0.3424    0.9396   -0.2411
0.0017    0.3420    0.9398   -0.2415

Instrument Transformation Matrix (Down):      Q14:
1.4691   -1.4705    0.0078   -0.0067    24069   -24092    127    -109
-0.0068    0.0078   -1.4618    1.4606    -111    127   -23950   23930
0.2663    0.2657    0.2657    0.2661    4363    4354    4353    4359
1.0367    1.0350   -1.0359   -1.0374    16985   16957   -16972   -16996
Beam Angle Corrections Are Loaded.
>
```



If the Long Ranger / QuarterMaster has beam angle errors, they are reflected in the instrument transformation matrix and the Beam Directional matrix. This matrix, when multiplied by the raw beam data gives currents in the x , y , z , and e directions.

Pre-deployment Test

This diagnostic test checks the major Long Ranger / QuarterMaster modules and signal paths. Both *WinSC* and *TRDI Toolz* run this test. For example, the output may look like this:

```
>PA
PRE-DEPLOYMENT TESTS
CPU TESTS:
  RTC.....PASS
  RAM.....PASS
  ROM.....PASS
RECORDER TESTS:
  PC Card #0.....DETECTED
  Card Detect.....PASS
  Communication.....PASS
  DOS Structure.....PASS
  Sector Test (short).....PASS
  PC Card #1.....DETECTED
  Card Detect.....PASS
  Communication.....PASS
  DOS Structure.....PASS
  Sector Test (short).....PASS
DSP TESTS:
  Timing RAM.....PASS
  Demod RAM.....PASS
  Demod REG.....PASS
  FIFOs.....PASS
SYSTEM TESTS:
  XILINX Interrupts... IRQ3  IRQ3  IRQ3  ...PASS
  Wide Bandwidth.....PASS
  Narrow Bandwidth.....PASS
  RSSI Filter.....PASS
  Transmit.....PASS
SENSOR TESTS:
  H/W Operation.....PASS
```

Testing the Sensors



The **PC2 test** displays heading, pitch angle, roll angle, **up/down orientation** and temperature in a repeating loop at approximately 0.5-sec update rate.

To test the sensors, rotate and tilt the system and verify the Pitch and Roll sensor data is reasonable. Rotate the system clockwise and verify the heading increases. Validate the accuracy at 0, 90, and 180 degrees. If the heading is off by more than 2 degrees, [calibrate the compass](#). If the pressure is not zero, zero the pressure sensor with the AZ command.

```
Press any key to quit sensor display ...
Heading  Pitch  Roll  Up/Down  Attitude Temp  Ambient Temp  Pressure
301.01°  -7.42°  -0.73°  Up        24.35°C        22.97°C        0.0 kPa
300.87°  -7.60°  -0.95°  Up        24.36°C        22.97°C        0.0 kPa
300.95°  -7.60°  -0.99°  Up        24.37°C        22.97°C        0.0 kPa
300.71°  -7.61°  -0.96°  Up        24.37°C        22.98°C        0.0 kPa
```

Sign of Angle for a Unit Facing	Up	Down
Pitch - Beam 3 higher than Beam 4	+	+
Roll - Beam 2 higher than Beam 1	+	-

Any key pressed exits this command and returns the user to the command prompt. Both *WinSC* and *BBTalk* run this test.

Beam Continuity

The **PC1** tests the beam continuity by measuring the quiescent Receiver Signal Strength Indicator (RSSI) levels. There must be a change of more than 30 counts when the transducer face is rubbed. Both *WinSC* and *TRDI Toolz* run this test.

The **PC1** test is designed to measure the relative noise in the environment and then have you apply more noise by rubbing the ceramics with your hand. So metimes your hand does not generate enough noise for the system to detect. This could be due to the environment you are in or for other reasons. A simple, safe, and easy to find material that works very well as a replacement to your hand is packaging material (a.k.a. bubble wrap). Using this instead of your hand will very likely provide enough relative frictional difference for the system to pass.

```
BEAM CONTINUITY TEST
When prompted to do so, vigorously rub the selected
beam's face.
If a beam does not PASS the test, send any character to
the ADCP to automatically select the next beam.
```

```
Collecting Statistical Data...
 52 48 50 43
```

```
Rub Beam 1 = PASS
Rub Beam 2 = PASS
Rub Beam 3 = PASS
Rub Beam 4 = PASS
```

This test must be performed with the ADCP out of water and preferably dry.

If the **PC1** test fails, your system may still be okay. In this case deploy the ADCP into a bucket or container of water (preferably at least 0.5 meters deep). Record some data using *TRDI Toolz* and the log file (**F3** key), or record data straight to the recorder card if your ADCP has one. Then look at the data using the *WinADCP* program and make sure that the echo amplitude counts in the 1st depth cell for all beams is between 128 and 192. If they are not, contact Field Service for further troubleshooting tips.

Chapter 6

TROUBLESHOOTING



In this chapter, you will learn:

- Basic Steps in Troubleshooting
- Troubleshooting a Communication Failure
- Troubleshooting a Built-In Test Failure
- Troubleshooting a Beam Failure
- Troubleshooting a Sensor Failure
- System Overview

Considering the complexity of the Long Ranger / QuarterMaster, TRDI has provided as much information as practical for field repair; *fault location to the component level is beyond the scope of these instructions.* The provided information assumes that faults are isolated with a large degree of certainty to a Least Replaceable Assembly (LRA) level only. The time to repair the system will be minimized if an entire replacement unit is available in the field. If time to repair is of essence, Teledyne RD Instruments strongly advises the availability of the listed LRAs.

Table 3: List of Least Replaceable Assemblies

LRA	Description
Long Ranger / QuarterMaster	The entire Long Ranger / QuarterMaster; includes the electronics, housing, transducer ceramic assemblies, and end-cap.
I/O Cable	Connects the ADCP with the Computer.
Housing	Includes the housing, connector, and internal I/O cable.
Long Ranger / QuarterMaster electronics	The spare boards kit Includes the High Power I/O, CPU, and DSP boards.
PC Card	Replaceable PC recorder card.

Since these Least Replaceable Assemblies are manufactured in different configurations, please contact [Teledyne RD Instruments](#) to obtain the correct part number for your specific system configuration. When contacting Teledyne RD Instruments about a replacement assembly, please provide the serial numbers of the ADCP and Deck Box. If you want to replace the I/O Cable only, then please provide the cable length.



TRDI needs the serial number of the unit so the correct beam angle matrix can be loaded into the board stack.

Equipment Required

Special test equipment is not needed for trouble shooting and fault isolation. The required equipment is listed in Table 4. Any equipment satisfying the critical specification listed may be used.

Table 4: Required Test Equipment

Required Test Equipment	Critical Specification
DMM	Resolution: 3 ½ digit DC-Voltage Range: 200 mV, 2V, 20 V, 200V DC-Voltage Accuracy: ± 1% AC-Voltage Range: 200 V, 450 V AC-Voltage Accuracy: ± 2% Resistance Range: 200, 2 k, 20 k, 200 k, 20 MOhm Res.-Accuracy: ± 2% @ 200 Ohm to 200 kOhm Res.-Accuracy: ± 5% @ 20 Mohm Capacitance Range: 20 nF, 2 uF, 20 uF Capacitance Accuracy: ± 5%
Serial Data EIA Break-Out Box such as from International Data Sciences, Inc. 475 Jefferson Boulevard Warwick, RI 02886-1317 USA.	Model 60 or similar is recommended as it eases the troubleshooting of RS-232 communication problems significantly. Other manufacturers or models may be substituted.



The EIA Break-out Panel is not necessary, but eases RS-232 communication problems troubleshooting significantly.

Basic Steps in Troubleshooting

The first step in troubleshooting is determining what type of failure is occurring. There are four types of failures:

- Communication failure
- Built-In test failure
- Beam failure
- Sensor failure

Communication failures can be the hardest problem to solve as the problem can be in any part of the system (i.e. the computer, Long Ranger / QuarterMaster, cable, or power). The symptoms include having the system not respond, or not responding in a recognizable manner (for example “garbled” text).

Built-In test failures will appear when the system diagnostics are run. Use *WinSC* or *TRDI Toolz* to identify the failing test.

Beam failures can be identified when collecting data or during the user-interactive performance tests.

Sensor failures can also be identified when collecting data or during the user-interactive performance tests. The sensor may send incorrect data, or not be identified by the system.

Troubleshooting the ADCP

Although the Long Ranger / QuarterMaster is designed for maximum reliability, it is possible for a fault to occur. This section explains how to troubleshoot and fault isolate problems to the Least Replaceable Assembly level (see Table 3). Before troubleshooting, review the procedures, figures, and tables in this guide. Also, read the [System Overview](#) to understand how the Long Ranger / QuarterMaster processes data.



Under all circumstances, follow the safety rules listed in the Troubleshooting Safety.

Troubleshooting Safety

Follow all safety rules while troubleshooting:



Servicing instructions are for use by service-trained personnel. To avoid dangerous electric shock, do not perform any service unless qualified to do so.



Complete the ground path. The power cord and the outlet used must have functional grounds. Before power is supplied to the Long Ranger / QuarterMaster, the protective earth terminal of the instrument must be connected to the protective conductor of the power cord. The power plug must only be inserted in a socket outlet provided with a protective earth contact. The protective action must not be negated by the use of an extension cord (power cable) without a protective conductor (grounding). Grounding one conductor of a two-conductor outlet is not sufficient protection.



Any interruption of the earthing (grounding) conductor, inside or outside the instrument, or disconnecting the protective earth terminal will cause a potential shock hazard that could result in personal injury.



Only fuses with the required rated current, voltage, and specified type must be used. Do not repair fuses or short circuit fuse-holders. To do so could cause a shock or fire hazard.



Do not install substitute parts or perform any unauthorized modifications to the instrument.



Measurements described in the manual are performed with power supplied to the instrument while protective covers are removed. Energy available at many points may, if contacted, result in personal injury.



Do not attempt to open or service the power supply.



Any maintenance and repair of the opened instrument under voltage should be avoided as much as possible, and when inevitable, should be carried out only by a skilled person who is aware of the hazard involved.



Capacitors inside the instrument may still be charged even if the instrument has been disconnected from its source of supply.

Troubleshooting a Communication Failure

Long Ranger / QuarterMaster ADCPs communicate by means of two serial communication channels. The user can choose between RS-232 and RS-422 classes of serial interfaces with a switch on the High Power Amplifier Board in the ADCP.

To successfully communicate, both the host computer and the ADCP must communicate using the same class of serial interface. Standard serial interfaces in IBM compatible computers are also RS-232.



If you have just received your Long Ranger / QuarterMaster from TRDI, the standard configuration is RS-232 for Long Ranger / QuarterMasters.



If you are using a high baud rate and/or a long I/O cable (greater than 50 meters) connected to a Long Ranger / QuarterMaster ADCP, RS-232 may not work. Switch to RS-422 and try to wake up the Long Ranger / QuarterMaster again.



Most communication problems are associated with incorrect cabling (i.e. the serial cable is connected to the wrong port) or data protocols (i.e. the wrong baud rate is set between the ADCP and computer).

Incorrect Wakeup Message

When you send a break and the wakeup message is not readable (garbled), this may indicate a communications mismatch or lost boot code.

- Sending a break causes “garbage” to appear on the screen. The “garbage” text may keep scrolling. This happens when the computer is using RS-232 and the ADCP is set for RS-422 or vice-versa. Check the RS-232/RS-422 switch on the High Power Amplifier Board (see [Communications Setting](#)).

- Sending a break causes “garbage” to appear on the screen. You can hear the ADCP “beep” when the break is sent. The “garbage” text does not keep scrolling. Check that the ADCP and computer are both using the same baud rate. See the CB-command in the WorkHorse Command and Output Data Format guide.
- If the ADCP gives a steady “beep” when power is applied, the “>” prompt appears on the screen, and an “X” appears when additional breaks are sent, this may indicate that the boot code has been lost. This can happen if you abort while downloading new firmware. Try downloading the firmware again.

No Wakeup Message

When you send a Break and do not see the wakeup message, you need to isolate the problem to a computer fault, power, cable failure, or an ADCP problem.

Check the following items:

1. Connect the ADCP to a computer as shown in [Setting up the Long Ranger / QuarterMaster System](#). Check that all cable connections are tight.
2. Is the ADCP AC power adapter working? Is the input voltage to the AC power adapter between 100 to 240 VAC? Is the output level 48 VDC?
3. If the ADCP is running from a battery, check that the battery voltage is above 30 VDC. ADCPs will work at 20 VDC with at least 400 milli amps; however, both lithium and alkaline battery packs with voltages below 30 VDC are at or near their end of life, and are approaching uselessness.
4. Is the computer hooked up properly? Does it have power?
5. Make sure that your computer and the *TRDI Toolz* programs are set up to use the communication port the serial cable is connected to on the computer.
6. In the case where the ADCP is only able to accept a SOFT BREAK due to telemetry components that will not “pass” a HARD BREAK to the ADCP and where you can cycle power, TRDI recommends that you consider removing power for one week. Re-apply power after a week and the ADCP should wake up.



The ADCP automatically stores the last set of commands used in RAM. Removing power for one week allows the RAM to lose its backup power. When power is re-applied, the ADCP will then do a ‘cold start’ (see [ADCP Checks](#)).

This is something that can be done without recovering the instrument. It assumes power can be cycled without recovering the ADCP and the ADCP is still functioning. The cost benefits of waiting a week needs to be weighed against the cost of divers recovering the ADCP.

Check the Power

The following test can be done with a voltmeter to check the power. Check the power going into the ADCP by measuring the voltage on the end of the cable that connects to the Long Ranger / QuarterMaster at Pins 3 and 7 (GND) (see [Long Ranger / QuarterMaster Cables](#)). The voltage should be +48 VDC (using the standard AC adapter) or +48 VDC if you are using the Deck Box. If not, check the voltage at the other end of the cable, the AC adapter.

Check the I/O Cable

This test will check the communication between the computer and Long Ranger / QuarterMaster.

To check the cable:

1. Disconnect both ends of the cable and measure the continuity using a DMM (see [Cable Wiring Diagrams](#)). Correct any problems found.
2. Reconnect the I/O cable to host computer.
3. Load *TRDI Toolz* on your computer. Select the proper communications port (see the *TRDI Toolz User's Guide* for help on using *TRDI Toolz*).
4. For RS-232 communications, short pins 1 and 2 together on the female 7-pin connector that was plugged into the Long Ranger / QuarterMaster (see [Cable Wiring Diagrams](#)). If you are using RS-422, connect a jumper between pin 2 to pin 6 and another jumper between pins 1 to pin 5 of the underwater connector at the Long Ranger / QuarterMaster end of the cable.
5. Type any characters on the keyboard. The keys you type should be echoed on the screen. If you see characters, but not correctly (garbage), the cable may be too long for the baud rate. Try a lower baud rate. If this works disconnect the jumper on pins 1 and 2 and then push any keys on the keyboard. You should NOT see anything you type.
6. If the keys are echoed correctly on the screen, the computer and the communication cable are good. Re-connect the I/O cable to the Long Ranger / QuarterMaster. The above loop-back test does not show if transmit and receive pairs are interchanged. Thus, it is important that you check the wiring diagrams provided in [Cable Wiring Diagrams](#).



A loop-back test does not show if transmit and receive wires or pairs are interchanged, even though characters may be displayed correctly.

ADCP Checks

Once you have eliminated possible problems with the power, I/O cable, communications settings, and the computer, that leaves the ADCP as the source of the problem. The following checks may help in some situations.

To Cold Start the ADCP:

1. To drain the Long Ranger / QuarterMaster High Power Assembly capacitor bank make the Long Ranger / QuarterMaster ping as fast as possible with the maximum number of bins. While it is pinging, disconnect power. The Long Ranger / QuarterMaster will continue pinging until the capacitors are drained.
2. Remove the housing to gain access to the PC boards.
3. With your earth-ground static protection strap on, use a 3 mm Allen wrench to remove the four bolts that secure the High Power Amplifier Assembly to the shield.
4. Tilt the High Power Amplifier Assembly up enough to disconnect the I/O and Transmit cables (P1 and P2). Set the High Power Amplifier Assembly aside.



Disconnect the power cables P1 and P2 on the High Power I/O board to ensure that NO POWER is applied to the Long Ranger / QuarterMaster during the next step.

5. Short TP3 to TP4 on the High Power I/O board for 10 seconds. The test points are located next to the ground jumper.
6. Remove the jumper used to short TP3 to TP4.

7. Reconnect power cable P1 and P2. Secure the High Power Amplifier Assembly to the shield.
8. Connect the computer and power to the Long Ranger / QuarterMaster. Send a break to the Long Ranger / QuarterMaster. This should start the Long Ranger / QuarterMaster in the “cold start” mode.

To check the fuse:

Check the fuse on the End-Cap Interface board is not blown (see [Fuse Replacement](#)).



Only fuses with the required rated current, voltage, and specified type must be used. Do not repair fuses or short circuit fuse-holders. To do so could cause a shock or fire hazard.

Check for Boot Code Error:

If the ADCP gives a steady “beep” when power is applied, the “>” prompt appears on the screen, and a “X” appears when additional breaks are sent, this may indicate that the boot code has been lost. This can happen if you abort while downloading new firmware. Try downloading the firmware again.

Another possible problem could be a flooded system. Open the ADCP and check for water. If the system has flooded, return it to TRDI for repair (see [Technical Support](#)).

Troubleshooting a Built-In Test Failure

The built-in diagnostic tests check the major ADCP modules and signal paths. The spare boards kit may be used to repair some failures. This kit includes:

- Spare Boards including High Power I/O board, CPU board, and DSP board. These boards are held together with the standard M4 screw assembly and kept inside a protective anti-static bag.
- A disk containing your original beam cosine matrix table
- Tools for installation



The Spare Boards kit is not included with the system. You can order the kit by contacting Teledyne RD Instruments Customer Service department (see [How to Contact Teledyne RD Instruments](#) and Table 2, page 63).

The High Power Amplifier Assembly, Tuning, and Receiver boards are not included in the Spare Board kit. See [Installing the Spare Boards Kit](#) for instructions.

When to use the Spare Boards Kit

Use this Kit whenever you have any of the following problems:

- Cannot communicate to the Long Ranger / QuarterMaster and you have ensured that the serial port on the computer, Long Ranger / QuarterMaster Cable, and Long Ranger / QuarterMaster RS-232 to RS-422 converter (if applicable) are all working properly.
- Your Long Ranger / QuarterMaster fails any of the following PA tests at any time:

CPU Tests:

- RTC
- RAM
- ROM

DSP Tests:

- Timing RAM
- Demod RAM
- Demod REG
- FIFOs

System Tests:

- XILINK Interrupts
- Receive Loop Back Test

- Your Long Ranger / QuarterMaster fails any of the following PA tests provided the items indicated by {} have been checked:

Recorder Tests:

Any recorder tests fails {provided that the PCMCIA card(s) have been checked for proper installation, operation and they are DOS formatted; we STRONGLY recommend checking PCMCIA cards in a computer before replacing the boards}

System Tests:

Transmit {if the Long Ranger / QuarterMaster fails when it is in water and air bubbles have been rubbed from the faces}

Sensor Tests:

H/W Operation {if the Long Ranger / QuarterMaster fails when it is NOT sitting/resting on its side, or located near a large magnetic field like a motor in a boat}

The spare boards kit will not correct any of the following failures:

- A damaged beam or its urethane surface
- Damage to the transducer beam connections below the copper shield
- If it passes all PA tests and yet the data is all marked as bad
- Fails the following PA test:

System Tests:

Wide Bandwidth {bandwidth tests may fail due to external interference}

Narrow Bandwidth {bandwidth tests may fail due to external interference}

RSSI Filter

Transmit

Table 5: Pre-deployment Test (PA) Possible Cause of Failures

PA Test Name	Possible Cause of Failure
Pre-Deployment Tests CPU Tests: RTC RAM ROM	CPU board failed
Recorder Tests: PC Card #0 Card Detect Communication DOS Structure Sector Test (short) PC Card #1 Card Detect Communication DOS Structure Sector Test (short)	PC card not plugged in PC card failed DSP board failed
DSP Tests: Timing RAM Demod RAM Demod REG FIFOs	DSP board failed
System Tests: XILINX Interrupts	DSP or CPU board failed
Receive Loop-Back	DSP or CPU board failed
Wide Bandwidth	Not in water External interference DSP or Receiver board failed
Narrow Bandwidth	
RSSI Filter	
Transmit	Not in water or High Power Amplifier board failed
Sensor Tests: H/W Operation	High Power Amplifier board failed Receiver board failed Pressure sensor failed ADCP laying on its' side

Troubleshooting a Beam Failure

The PC1 test is designed to measure the relative noise in the environment and then have you apply more noise by rubbing the ceramics with your hand. Sometimes your hand does not generate enough noise for the system to detect. This could be due to the environment you are in or for other reasons. A simple, safe, and easy to find material that works very well as a replacement to your hand is packaging material (a.k.a. bubble wrap). Using this instead of your hand will very likely provide enough relative frictional difference for the system to pass.

If the PC1 test fails, your system may still be okay. In this case deploy the ADCP into a bucket or container of water (preferably at least 0.5 meters deep). Record some data using *TRDI Toolz* and the log file (**F3** key), or record data straight to the recorder card if your ADCP has one. Then look at the data using the *WinADCP* program and make sure that the echo amplitude counts in the 1st depth cell for all beams is between 128 and 192. If they are not, contact Field Service for further troubleshooting tips.

If the beam continuity test still fails and/or the echo amplitude indicates a problem, a bad DSP board, Receiver board, High Power Amplifier Board, or a bad beam may cause the failure. If replacing the DSP and High Power Amplifier Board (included with the spare boards kit) does not fix the problem, the ADCP must be returned to TRDI for repair.

```
>PC1

BEAM CONTINUITY TEST

When prompted to do so, vigorously rub the selected
beam's face.

If a beam does not PASS the test, send any character to
the ADCP to automatically select the next beam.

Collecting Statistical Data...
  41  46  45  43  41  46  45  43  41  46  45  42  41  46  44  42

Rub Beam 1 = PASS |   NOTE - Possible cause of failure
Rub Beam 2 = PASS |           DSP Board
Rub Beam 3 = PASS |           Receiver Board
Rub Beam 4 = PASS |           High Power I/O Board
> |           Beam
```



This test must be performed with the ADCP out of water and preferably dry.

Troubleshooting a Sensor Failure

If the PA test fails the sensor test, run PC2 to isolate the problem. The ambient temperature sensor is mounted on the receiver board. This sensor is imbedded in the transducer head, and is used for water temperature reading. The attitude temperature sensor is located on the High Power Amplifier Board under the compass. The ADCP will use the attitude temperature if the ambient temperature sensor fails.

If one of the temperature sensors fails, the PC2 test will show both sensors at the same value.

```
>PC2
Press any key to quit sensor display ...

Heading   Pitch    Roll    Up/Down   Attitude Temp   Ambient Temp   Pressure
301.01°   -7.42°   -0.73°   Up        24.35°C         22.97°C       0.0 kPa
300.87°   -7.60°   -0.95°   Up        24.36°C         22.97°C       0.0 kPa
300.95°   -7.60°   -0.99°   Up        24.37°C         22.97°C       0.0 kPa
300.71°   -7.61°   -0.96°   Up        24.37°C         22.98°C       0.0 kPa
300.69°   -7.61°   -0.96°   Up        24.35°C         22.98°C       0.0 kPa
300.76°   -7.60°   -0.98°   Up        24.38°C         22.97°C       0.0 kPa
>
```



If the temperature sensor is bad, the data can still be collected with no effects to accuracy or quality. Contact TRDI about scheduling a repair of the temperature sensor at your convenience.

Fault Log

To determine why a sensor failed, view the fault log. To view the fault log, start *TRDI Toolz*. Press the **End** key to wake up the ADCP. Type the following commands: **CR1**, **PA**, **FD**, **FC**. The fault log will be displayed by the **FD** command and is cleared by the **FC** command.

```
[BREAK Wakeup A]

WorkHorse Broadband ADCP Version x.xx
Teledyne RD Instruments (c) 1996-2012
All rights reserved.
[BREAK Wakeup A]
>CR1
>PA
|           (PA test results (not shown))
|
>FD
Total Unique Faults   =      2
Overflow Count        =      0
Time of first fault:   97/11/05,11:01:57.70
Time of last fault:   97/11/05,11:01:57.70

Fault Log:
Entry #  0 Code=0a08h Count=    1 Delta=    0 Time=97/11/05,11:01:57.70
  Parameter = 00000000h
    Tilt axis X over range.
Entry #  1 Code=0a16h Count=    1 Delta=    0 Time=97/11/05,11:01:57.70
  Parameter = 00000000h
    Tilt Y axis ADC under range.
End of fault log.
>FC
```

System Overview

This section presents a functional description of Long Ranger / QuarterMaster operation using block diagrams.

Operating Modes

The Long Ranger / QuarterMaster has two modes of operation: *command mode*, and *ping mode* (also referred to as “Deployment Saver” Mode). Depending on what mode the ADCP is in; it will go either to sleep, or to resume ping.

Command Mode

Whenever you wake up your Long Ranger / QuarterMaster, power dissipation increases from less than 1 mW to around 2.2 W. If you leave the Long Ranger / QuarterMaster in command mode without sending a command for more than 5 minutes, the Long Ranger / QuarterMaster automatically goes to sleep. This protects you from inadvertently depleting batteries.

- If the ADCP receives a BREAK, it will go to the command prompt and wait for a command. The ADCP will wait at the command prompt for five minutes. If no commands have been sent, it will go to sleep (also called “Battery Saver” mode).
- If you press the reset switch (located on the CPU board), the ADCP will go to sleep.
- If the ADCP receives a CS-command, it will go into the ping mode and begin ping. If a TF-command (Time of First Ping) was sent prior to the CS-command, then the ADCP will go to sleep until the TF time occurs.
- If the ADCP does a COLD wakeup (i.e. an unknown state), it will go to the command prompt.
- If the ADCP is asleep for approximately nine hours, it wakes up to charge the capacitor used to maintain RAM. Once the capacitor is charged (this only takes a few seconds), the ADCP goes back to sleep.

Ping Mode

After you send commands to the Long Ranger / QuarterMaster that tells it to start collecting data, the Long Ranger / QuarterMaster goes into deployment saver mode. If power is somehow removed and later restored, the Long Ranger / QuarterMaster simply picks up where it left off and continues to collect data using the same set up.

- If the ADCP receives a BREAK, it will go to the command prompt, but stays in the ping mode. If a valid command is received, the ADCP will switch to the command mode. If no valid command is received, a warning will be displayed after four minutes, indicating that the system will self-deploy. After a total of five minutes with no input, the ADCP will resume ping.
- If you press the reset switch, and an alarm is currently set for the next ping, the ADCP will go to sleep. If no alarm is set, the system will start a new deployment and starts ping immediately unless a TF-command had been set after the last BREAK. In this case, the ADCP will go to sleep until the TF time occurs.
- If the ADCP does a COLD wakeup, the system will start a new deployment and starts ping immediately unless a TF-command had been set after the last BREAK. In this case, the ADCP will go to sleep until the TF time occurs if the TF time is valid (i.e., not in the past).
- If the ADCP is asleep for approximately nine hours, it wakes up to charge the capacitor used to maintain RAM. Once the capacitor is charged, if a valid alarm is set for the next ping time, the ADCP goes back to sleep and waits for the alarm. If no alarm is set, the ADCP will resume ping immediately, or wait for the TF time (if valid), and then start ping.

Overview of Normal ADCP Operation

Refer to Figure 64 through Figure 66. The following events occur during a typical data collection cycle.

1. The user or a controlling software program sends data collection parameters to the ADCP. The user/program then sends a CS-command to start the data collection cycle. The firmware program stored in the CPU microprocessor takes control of ADCP operation based on the commands received through the serial I/O cable.

Figure 64 shows a flow chart of the wake-up logic used by the ADCP. The ADCP determines what to do based on where the wake-up came from (a Break, CS-command, battery saver timer, or watchdog timer was detected).

2. On the High Power Amplifier Board, the POWER REGULATOR circuit sends a transmit command to the POWER AMPLIFIER circuit. This tells the ADCP to start acoustic transmissions (pinging) on all TRANSDUCERS.
3. The TRANSDUCERS receive echoes from the backscatter. The RECEIVER board amplifies and translates the echoes into a base-band frequency.
4. The CPU board processes the received echoes.
5. After echo reception, the ADCP injects a self-test signal into the RECEIVER board and processes the signal as normal data for test purposes.
6. The THERMISTOR measures water temperature at the transducer head and sends it to the CPU via the DSP Board.
7. The High Power Amplifier Board sends pitch and roll from the TILTSENSOR and ADCP heading from the COMPASS to the DSP Board. The DSP Board digitizes this information and sends it to the CPU for processing.
8. The CPU repeats steps “b” through “g” for a user-defined number of pings. The CPU averages the data from each ping to produce an ensemble data set.
9. At the end of the ensemble (sampling) interval, the CPU sends the collected data to the serial I/O connector or PCMCIA recorder.

Functional Description of Operation

The following paragraphs describe how the ADCP operates and interacts with its modules. Refer to Figure 64 through Figure 66 throughout this description.

Input Power

The ADCP requires a DC supply between 20 volts and 50 volts. Either an external DC power supply or internal battery packs can provide this power. Figure 65 shows the DC voltage power distribution path.

External DC Power Supply – With an external supply, power is applied to pins 3 (positive) and 7 (negative) on the external connector (see Figure 66). The power then goes through an electromagnetic interference (EMI) filter on the High Power Amplifier Board. This filter reduces the chance that external noise sources associated with the external power source can disrupt ADCP operation.

ADCP Internal Battery Packs – Each internal battery pack uses 28 alkaline “D” cells. Each pack supplies a nominal output voltage of 42 volts open circuit when fresh. The diode-isolated battery packs can only power the ADCP; they cannot “charge” each other.

Board Descriptions

High Power Amplifier Board.

- Receives the filtered/internal power.
- Uses a diode “OR” gate to determine which power source to use (external or internal). With both sources connected, the OR gate selects the “higher” voltage for ADCP use.
- Limits the in-rush of current to the ADCP and provides over and negative-voltage protection. Either condition will blow a protective fuse. However, damage could occur to other circuits before the fuse blows. Please ensure you apply only voltages within the specified range (+20 to +50 VDC).
- Uses the Power Amplifier circuit to generate the high-amplitude pulse AC signal that drives the sonar transducers. The Power Amplifier sends the drive signal to the Receiver Board.

High Power IO Board.

- Converts the operating power supply (filtered 20-50 VDC) in a DC-to-DC converter to the +5 VDC (Vcc) used to power all other ADCP circuits.
- Compass and attitude sensor circuits.
- RS-232/RS-422 switch.

CPU Board.

- Real time clock.
- Generates most of the timing and logic signals used by the ADCP.

DSP Board.

- Contains the PCMCIA recorder slots.
- Analog to Digital converter.
- Digitizes information from sensors and sends sensor information to the CPU.

Receiver Board.

- Tuning functions
- Receiver functions
- Temperature sensor
- Interface for pressure sensor

End-Cap Interface Board.

- Feeds through communication and power to the high power amplifier board.
- Provides connectors for the internal I/O cable and battery packs.

Sensors

This section describes the standard ADCP sensors. The High Power I/O and DSP boards control the environmental sensors and contain unit-specific data. Sensors include:

Temperature Sensor (Thermistor) - Used to measure the water temperature. The system uses this data to calculate the speed of sound. This sensor is embedded in the transducer head and is not field replaceable.

Up/Down Sensor - Determines whether the transducer head is facing up or down. This sensor is located on the High Power Amplifier Board.

Compass - Determines the Beam 3 heading angle of the ADCP using a flux-gate compass. This sensor is located on the High Power Amplifier Board. The flux-gate measured earth magnetic field vector together with the tilt sensor pitch and roll information is used to determine the heading. Since the tilt sensor data is only valid when the ADCP is $\pm 20^\circ$ from vertical, the heading information is also limited to this range.

Attitude Sensor - Determines the tilt angles of the ADCP. This sensor is located on the High Power Amplifier Board. The attitude sensor uses a pitch and roll liquid-filled sensor. This sensor is functional to an angle of $\pm 20^\circ$ from vertical.

Pressure Sensor - Measures pressure at the ADCP transducer. This sensor is embedded in the transducer head and is not field replaceable.

The CPU microprocessor controls a multiplexed analog-to-digital converter to accept analog data from the sensors. Digital data are taken in directly. The pressure sensor incorporates a Wheatstone Bridge strain gage to measure the water pressure at the transducer faces. Depth is calculated from pressure, with water density adjusted by the salinity (ES) setting.

Calibration data for the sensors, a beam-angle correction matrix, and unit identification parameters (frequency, serial number, firmware version, etc.) are stored in ROM.

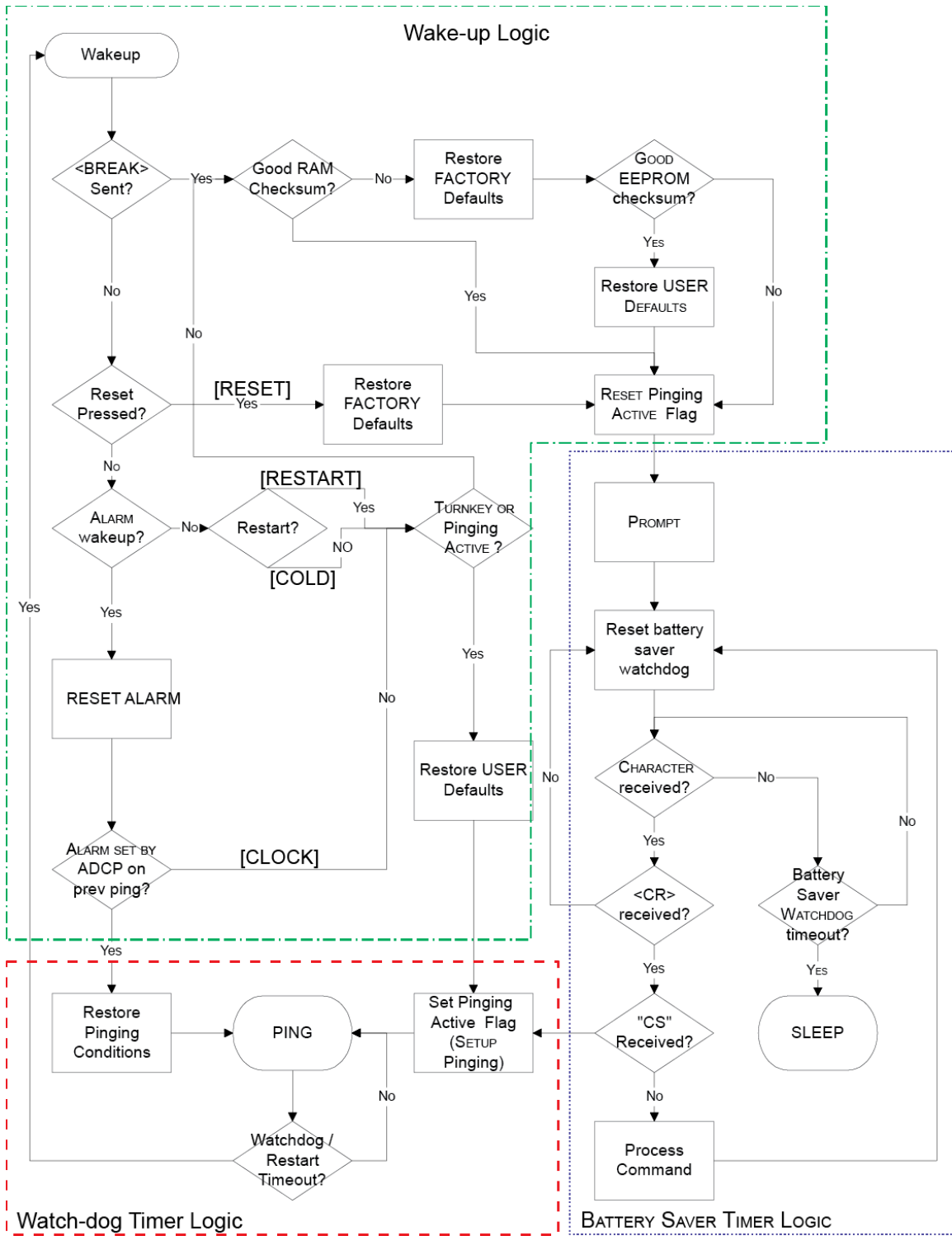

Figure 64. Long Ranger / QuarterMaster Wake-up and Timer Logic

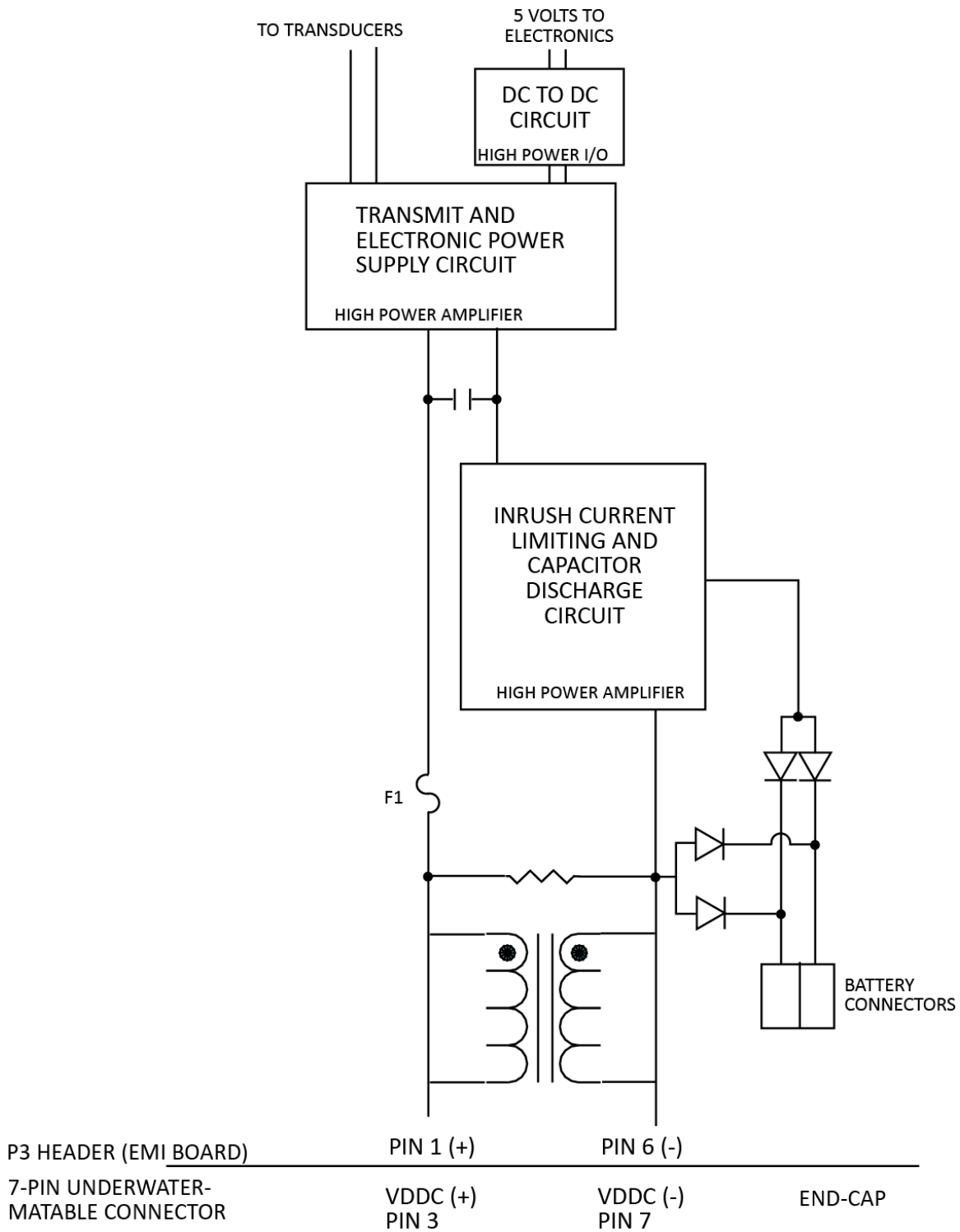

Figure 65. Long Ranger / QuarterMaster DC Power Path

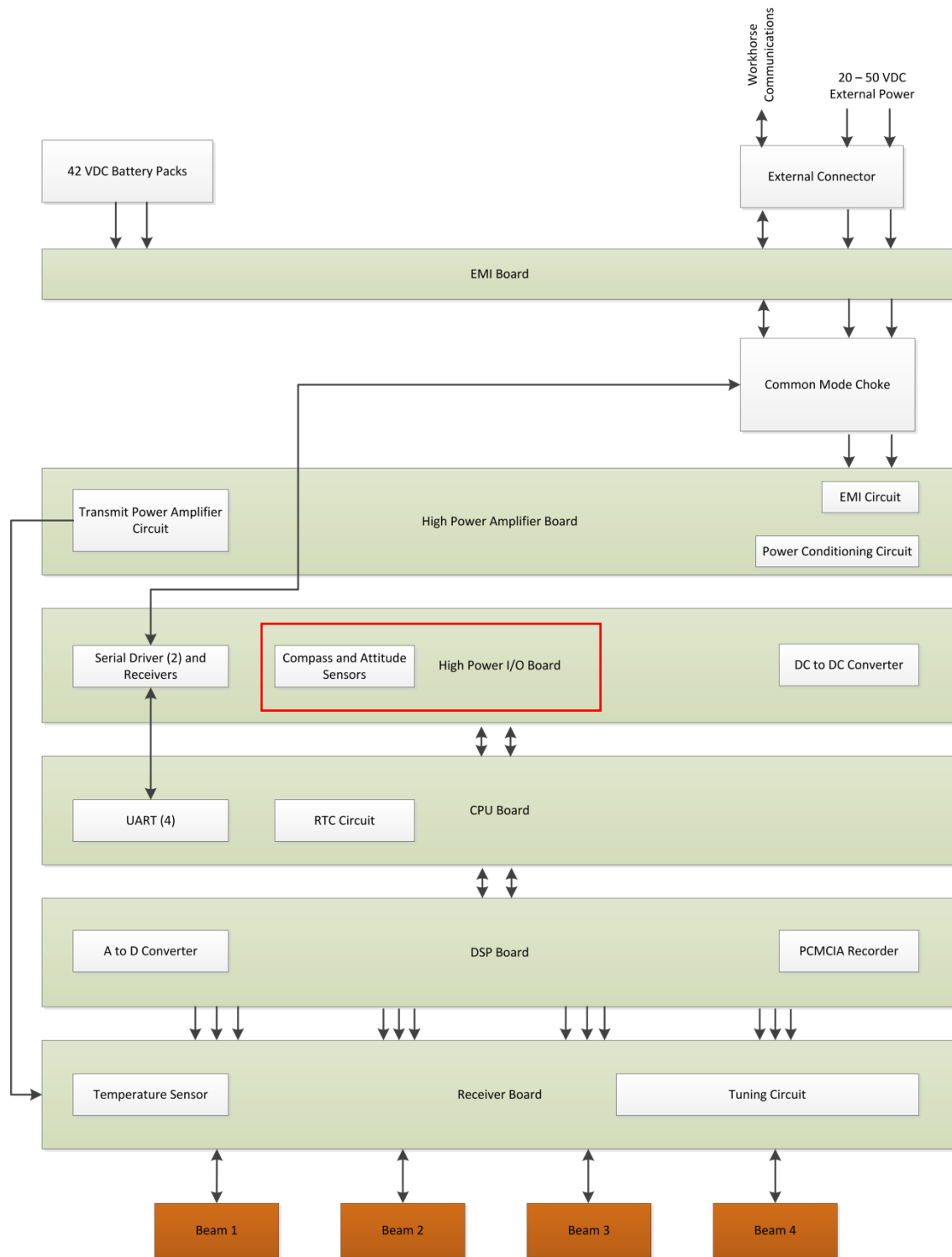

Figure 66. Long Ranger / QuarterMaster Block Diagram

Chapter 7

RETURNING SYSTEMS TO TRDI FOR SERVICE



In this chapter, you will learn:

- How to pack and ship the ADCP
- How to get a RMA number
- Where to send your ADCP for repair

Shipping the ADCP

This section explains how to ship the Long Ranger / QuarterMaster ADCP.



Remove all customer-applied coatings or provide certification that the coating is nontoxic if you are shipping a Long Ranger / QuarterMaster ADCP to TRDI for repair or upgrade. This certification must include the name of a contact person who is knowledgeable about the coating, the name, manufacturer of the coating and the appropriate telephone numbers. If you return the equipment without meeting these conditions, TRDI has instructed our employees not to handle the equipment and to leave it in the original shipping container pending certification. If you cannot provide certification, we will return the equipment to you or to a customer-specified cleaning facility. All costs associated with customer-applied coatings will be at the customer's expense.

When shipping the Long Ranger / QuarterMaster ADCP through a Customs facility, be sure to place the unit so identifying labels are not covered and can be seen easily by the Customs Inspector. Failure to do so could delay transit time.



TRDI strongly recommends using the original shipping crate whenever transporting the Long Ranger / QuarterMaster ADCP.

If you need to ship the Long Ranger / QuarterMaster ADCP, use the original shipping crate whenever possible. If the original packaging material is unavailable or unserviceable, additional material is available through TRDI.

For repackaging with commercially available materials:

1. Use a strong shipping container made out of wood or plastic.
2. Install a layer of shock-absorbing static-shielding material, 70-mm to 100-mm thick, around all sides of the instrument to firmly cushion and prevent movement inside the container.
3. Seal the shipping container securely.
4. Mark the container FRAGILE to ensure careful handling.
5. In any correspondence, refer to the Long Ranger / QuarterMaster ADCP by model and serial number.

Returning Systems to the TRDI Factory

When shipping the system to TRDI from either inside or outside the United States, the following instructions will help ensure the Long Ranger / QuarterMaster ADCP arrives with the minimum possible delay. Any deviation from these instructions increases the potential for delay.

Step 1 - Request a Return Material Authorization

To obtain a Return Material Authorization (RMA) number and shipping instructions for the return of your instrument, do one of the following:

- Open the RMA using the web link: <http://www.teledynemarine.com/RDI/support#> and click on **RMA Information**.
- Contact Customer Service Administration at rdicsadmin@teledyne.com
- Call +1 (858) 842-2600

When requesting a RMA number, please give us the following information:

- What is being shipped (include the serial number)
- When you plan to send the shipment
- What issue(s) need to be corrected
- Name of the Field Service Engineer that knows about the issue
- When you need the instrument returned

TRDI's Customer Service will then respond with the RMA number for the shipment. Please include this number on all packages and correspondence.

Step 2 – Provide a MSDS as necessary

Please provide a Material Safety Data Sheet (MSDS) if the system/transducer is painted with antifouling paint.

Step 3 - Ship via air freight, prepaid

Urgent Shipments should be shipped direct to TRDI via overnight or priority air services. Do not send urgent airfreight as part of a consolidated shipment. If you ship consolidated, it will cost less, but may lose up to three days in transit time.

Non-urgent shipments may be shipped as part of a consolidated cargo shipment to save money. In addition, some truck lines may offer equivalent delivery service at a lower cost, depending on the distance to San Diego.

Mark the Package(s)

To: Teledyne RD Instruments, Inc. (RMA Number)
14020 Stowe Drive
Poway, California 92064

Airport of Destination = San Diego
Notify Paxton, Shreve and Hayes

Phone: +1 (619) 232-8941
Fax: +1 (619) 232-8976

Step 4 - Urgent shipments

Send the following information by fax or telephone to TRDI.

Attention: Customer Service Administration

Fax: +1 (858) 842-2822

Phone: +1 (858) 842-2600

- Detailed descriptions of what you are shipping (number of packages, sizes, weights and contents).
- The name of the freight carrier
- Master Air bill number
- Carrier route and flight numbers for all flights the package will take

Returning Systems to TRDI Europe Factory

When shipping the system to TRDI Europe, the following instructions will help ensure the Long Ranger / QuarterMaster ADCP arrives with the minimum possible delay. Any deviation from these instructions increases the potential for delay.

Step 1 - Request a Return Material Authorization

To obtain a Return Material Authorization (RMA) number and shipping instructions for the return of your instrument, do one of the following:

- Open the RMA using the web link: <http://www.teledynemarine.com/RDI/support#> and click on **RMA Information**.

- Contact Customer Service Administration at rdiefs@teledyne.com
- Call +33(0)492-110-930

When requesting a RMA number, please give us the following information:

- What is being shipped (include the serial number)
- When you plan to send the shipment
- What issue(s) need to be corrected
- Name of the Field Service Engineer that knows about the issue
- When you need the instrument returned

TRDI's Customer Service will then respond with the RMA number for the shipment. Please include this number on all packages and correspondence.

Step 2 – Provide a MSDS as necessary

Please provide a Material Safety Data Sheet (MSDS) if the system/transducer is painted with antifouling paint.

Step 3 - Ship Via Air Freight, Prepaid

Urgent Shipments should be shipped direct to TRDI via overnight or priority air services. Do not send urgent airfreight as part of a consolidated shipment. If you ship consolidated, it will cost less, but may lose up to three days in transit time.

Non-urgent shipments may be shipped as part of a consolidated cargo shipment to save money.

Mark the package(s) as follows:

To: Teledyne RD Instruments, Inc. (RMA Number)
2A Les Nertieres
5 Avenue Hector Pintus
06610 La Gaude, France

Step 4 - Include Proper Customs Documentation

The Customs statement must be completed. It should be accurate and truthfully contain the following information.

- Contents of the shipment
- Value
- Purpose of shipment (example: "American made goods returned for repair")
- Any discrepancy or inaccuracy in the Customs statement could cause the shipment to be delayed in Customs.

Step 5 - Send the Following Information by Fax or Telephone to TRDI

Attention: Sales Administration

Phone: +33(0)492-110-930

Fax: +33(0)492-110-931

- Detailed descriptions of what you are shipping (number of packages, sizes, weights and contents).
- The name of the freight carrier
- Master Air bill number
- Carrier route and flight numbers for all flights the package will take

NOTES

Chapter 8

SPECIFICATIONS



In this chapter, you will learn:

- Specifications
- Outline Installation Drawings

A brief review of ADCP operation may help you understand the specifications listed in this section.



The specifications and dimensions listed in this section are subject to change without notice.

The Long Ranger / QuarterMaster emits an acoustic pulse called a PING. Scatterers that float at ambiently with the water currents reflect some of the energy from the ping back to the ADCP. The ADCP uses the return signal to calculate a velocity. The energy in this signal is the *echo intensity*. Echo intensity is sometimes used to determine information about the scatterers.

The velocity calculated from each ping has a *statistical uncertainty*; however, each ping is an independent sample. The ADCP reduces this statistical uncertainty by averaging a collection of pings. A collection of pings averaged together is an *ensemble*. The ADCP’s maximum *ping rate* limits the time required to reduce the statistical uncertainty to acceptable levels.

The Long Ranger / QuarterMaster does not measure velocity at a single point; it measures velocities throughout the water column. The ADCP measures velocities from its transducer head to a specified range and divides this range into uniform segments called *depth cells* (or *bins*). The collection of depth cells yields a *profile*. The ADCP produces two profiles, one for velocity, and one for echo intensity.

The following tables list the specifications for the Long Ranger / QuarterMaster ADCP. About the specifications:

1. All these specifications assume minimal ADCP motion - pitch, roll, heave, rotation, and translation.
2. Except where noted, this specification table applies to typical set ups and conditions. Typical set ups use the default input values for each parameter (exceptions include Pings Per Ensemble and Number of Depth Cells). Typical conditions assume uniform seawater velocities at a given depth, moderate shear, moderate ADCP motion, and typical echo intensity levels.
3. The total measurement error of the ADCP is the sum of:
 - Long-term instrument error (as limited by instrument accuracy).
 - The remaining statistical uncertainty after averaging.
 - Errors introduced by measurement of ADCP heading and motion.
4. Because individual pings are independent, the statistical uncertainty of the measurement can be reduced according to the equation:

$$\frac{\text{Statistical Uncertainty for One Ping}}{\sqrt{\text{Number of Pings}}}$$

Table 6: Water Velocity Profiles

Item	Specification
Depth cell size	75 kHz 4 to 32 m
	150 kHz 2 to 24 m
Number of depth cells	1 to 255 cells
Velocity range	±5 m/s default (±10 m/s max)
Ping rate	>1 Hz (typical)
Accuracy	± 1% ± 5 mm/s

Table 7: Echo Intensity Specifications

Item	Specification
Sampling	Uses same depth cells and time intervals as velocity
Uncertainty	±1.5 dB (relative measure)
Dynamic range	80 dB

Table 8: Measurement Performance - Long Ranger 75 kHz

Mode	Depth cell size (m)	Single Ping Std Dev (cm/s)	Standard Dev (cm/s) ¹	First cell range (m) ²	Max Range (m) ^{4, 5}	Power Usage (Wh) 66 day Deployment
Narrow BW Low Power	4	29.77	4.21	11.11	367.26	112.97
	8	14.87	2.10	15.02	397.90	170.29
	16	7.45	1.05	22.85	434.07	284.93
	32	3.75	0.53	38.50	474.21	514.20
Narrow BW High Power	4	29.77	4.21	12.71	524.53	598.84
	8	14.87	2.10	16.62	559.69	998.44
	16	7.45	1.05	24.45	600.12	1798.60
	32	3.75	0.53	40.10	644.09	3398.93
Wide BW Low Power	4	15.52	2.19	11.03	211.83	80.80
	8	7.76	1.10	14.98	236.92	116.70
	16	3.89	0.55	22.87	267.23	188.51
	32	1.96	0.28	38.65	301.63	332.13
Wide BW High Power	4	15.52	2.19	12.85	432.06	623.16
	8	7.76	1.10	16.80	464.82	1029.56
	16	3.88	0.55	24.69	502.99	1842.37
	32	1.96	0.28	40.47	544.90	3467.99



The default (and default commands) for Long Ranger’s using *PlanADCP* is to set **Narrow-Bandwidth (WB command)** and **High-Power mode (CQ command)**. Power setting and bandwidth are set in *PlanADCP* through the hardware selection page. See the *WinSC* and *PlanADCP User's Guide* for details.



1. Standard deviation is Long Ranger uncertainty given 50 water pings and ambiguity velocity set to 1.75m/s.
2. The first cell range is the distance from the transducer to the center of the first cell.
3. The minimum depth assumes one good depth cell.
4. Maximum range is a nominal value based on 5°C and typical oceanic backscatter; actual range will vary depending on environmental conditions.
5. Assuming the Long Ranger is pointed vertically (0° tilt), the maximum range is limited to 94% of the distance to the surface due to side lobe contamination.

Table 9. Measurement Performance – QuarterMaster 150 kHz

Version	Mode	Depth cell size (m)	Single Ping Std Dev (cm/s)	Standard Dev (cm/s) ¹	First cell range (m) ²	Max Range (m) ^{4, 5, 6}	Power Usage (Wh) WP / with BT
Standard Power	Wide BW	4	7.28	0.99	8.4	219	83/106
		8	3.64	0.5	12.3	241	109/131
		16	1.83	0.25	20.2	265	168/192
		24	1.22	0.16	28.1	280	225/252
	Narrow BW	4	14.08	1.96	8.3	279	90/116
		8	7.02	1.01	12.2	303	116/142
		16	3.52	0.5	20.0	328	172/199
		24	2.30	0.32	28.3	346	228/255
	Bottom Track					550	
	High Power Extended Range	Wide BW	4	7.28	0.99	8.4	246
8			3.64	0.5	12.34	268	182/213
16			1.83	0.25	20.23	293	309/365
24			1.22	0.16	28.13	308	435/512
Narrow BW		4	14.08	1.96	8.3	308	128/151
		8	7.02	1.01	12.21	331	186/219
		16	3.52	0.5	20.02	358	309/363
		24	2.30	0.32	28.32	376	448/527
Bottom Track						575	



The default (and default commands) for QuarterMaster’s using *PlanADCP* is to set Narrow-Bandwidth mode (WB command). The High Power Extended Range (QuarterMaster 6000m depth version only) increases transmit power by a factor of 2.25. The higher power output maintains high performance and the maximum possible range performance in deep, low backscatter waters.



1. Standard deviation is QuarterMaster uncertainty given 50 water pings and ambiguity velocity set to 1.75m/s.
2. The first cell range is the distance from the transducer to the center of the first cell.
3. The minimum depth assumes one good depth cell.
4. Maximum range is a nominal value based on 5°C and typical oceanic backscatter; actual range will vary depending on environmental conditions.
5. Assuming the QuarterMaster is pointed vertically (0° tilt), the maximum range is limited to 94% of the distance to the surface due to side lobe contamination.
6. Assumes a power supply of 32VDC (typical battery voltage).
7. Power usage (Wh) based on 100 day deployment with Water Profiling only and with Bottom Track on. 1 ensemble per hour is used and bin count is sized for each setup to allow profiling to full predicted range but not further.

Table 10: Data Communication Specifications

Item	Specification
Interface	RS-232 (default) or RS-422 serial communications
Baud rate	300 to 115,200 (9600 is default)
Input data format	ASCII commands (see Long Ranger / QuarterMaster Commands and Output Data Format Guide)
Output data format	Binary or ASCII
Internal data storage	The Long Ranger / QuarterMaster ADCPs include one memory card. Two PCMCIA memory card slots are available. The maximum memory for each slot is 2GB, with the total memory capacity not to exceed 4GB.

Table 11: Transducer and Hardware Specifications

Item	Specification
Frequencies	
	Long Ranger 76.8 kHz
	QuarterMaster 153.6 kHz
Bandwidths	
Broadband mode	25%
Long Range mode	6%
Beam width	4°
Beam angle	20°
Configuration	4-beam, convex
Max tilt	20°
Housing and transducer material	6061 Aluminum for 1500 and 3000 meter, 7075 Aluminum for 6000 meter
Transducer facing	Polyurethane
External connector	7-pin wet-mate-able

Table 12: Power Specifications

Item	Specification
DC input	20 to 50 VDC
Batteries	
No. of packs	4 (Standard Long Ranger) 2 (standard QuarterMaster configuration)
Cells	28 Alkaline D-cells (each pack)
Construction	Welded, degaussed
Voltage	42 VDC (new), 28 VDC (depleted)
Capacity @0°C	450 watt-hours (each pack)
Power required	
Process	2.2 W
Standby	6 mW
Long Ranger Transmit power @ 35 V	
High Power Narrow-Bandwidth mode ¹	1000 W
Narrow-Bandwidth mode, low power ¹	80 W
Wide-Bandwidth mode, low power ¹	20 W
QuarterMaster Transmit power @ 35 V	
Standard power Narrow-Bandwidth mode ²	150 W
Standard power Wide-Bandwidth mode ²	150 W
High Power Extended Range Narrow-Bandwidth mode ^{2,3}	300 W
High Power Extended Range Wide-Bandwidth mode ^{2,3}	300 W

- 
- 1. The default (and default commands) for Long Ranger’s using *PlanADCP* is to set Narrow-Bandwidth (WB command) and High-Power mode (CQ command).**
 - 2. The default (and default commands) for QuarterMaster’s using *PlanADCP* is to set Narrow-Bandwidth mode (WB command).**
 - 3. The High Power Extended Range is available for QuarterMaster 6000m depth version only.**

Table 13. Lithium Battery Specifications

Item	Specification	
Nominal voltage:	34 VDC	
Weight:	2.8 kg	
Self-discharge:	0.7%/year (10 year old packs hold 93% of their original capacity)	
Capacity (Whr)	Temperature	Capacity (Whr)
	0° C	1350
	10° C	1500
	20° C	1650
	37° C	1450

Table 14: Standard Sensors

Pressure Sensor ⁽¹⁾	
Max. pressure	2250 psi (1500 meters) to 8760 psi (6000 meters) maximum
Short-term uncertainty	±0.1%
Max. drift	±0.25%
Temperature (Transducer Mounted)	
Range	-5° to 45° C
Uncertainty	±0.4° C
Resolution	0.01°
Tilt	
Range:	±40°
Accuracy:	±0.5°
Precision:	±1.0°
Resolution:	0.1°
Compass ⁽²⁾	
Type	flux gate
Long-term accuracy	±2° @ 60° magnetic dip angle
Resolution	0.01°
Max tilt	20°



1. Includes built-in field calibration procedure. Compass uncertainty is for tilts less than 15°.
2. Other pressure ratings may be special-ordered.

Table 15: Environmental Specifications

Item	Specification
Operating temperature with or without batteries	-5° to 45°C
Short Term Storage/Shipping (<45days) temperature (Batteries Installed)	-5° to 45°C
Long Term Storage (>45days) temperature (Batteries Installed)	0° C to 21° C
Long Term Storage (>45days) temperature (Batteries Removed)	-30° to 60°C
Long Term (>45days) Battery Storage	Batteries should be stored in cool dry air with a temperature range of 0° C to 21° C.
Battery Shelf Life	Use within one year (use by Warning date).



Do not deploy the system with batteries that are older than the Warning date. It should be noted, that while a battery pack will not be dead after the Warning date, the actual performance of the battery is in doubt, and may not have sufficient capacity for the deployment.



TRDI batteries have four dates on them:

- Manufacture Date is the date the battery was built and final tested.
- TRDI Ship by Date provides the maximum duration that the battery will remain on our shelves before we will ship and is 6 months after our manufacture date.
- Warning Do not Deploy After Date* provides the last date when the battery should be used to start a deployment and is 12 months from the manufacture date.
- Expiration Date provides the date when the battery should no longer be considered useful and is 2 years from the manufacture date.

***A battery pack used to start a deployment prior to the Warning Date means that it will perform as expected and provide the required power for any deployment that was created using the TRDI planning module. For example, if your deployment is going to be 12 months long and the battery label shows it is nine months old, it is safe to use the battery.**

Outline Installation Drawings

The following drawings show the Long Ranger / QuarterMaster dimensions and weights.

Table 16: Outline Installation Drawings

Description	Drawing #
QuarterMaster 150 kHz, 6000 meters	967-1082
Long Ranger, 75kHz, 1500 meters	967-6021
Long Ranger / QuarterMaster External Battery Case, 1500 meters	967-6051
Long Ranger, 75kHz, 3000 meters	967-6055
QuarterMaster 150 kHz, 3000 meters	967-6082
QuarterMaster 150 kHz, 1500 meters	967-6083
QuarterMaster 150 kHz, 1500 meters, Modular Beams	967-1106
Long Ranger / QuarterMaster External Battery Case, 3000 meters	967-6085



Outline Installation Drawings are subject to change without notice. Verify you have the latest version of the drawing by contacting TRDI before building mounts or other hardware.



Outline installation drawing 967-1106 shows the dimensions and weights for all 150kHz systems shipping after July 2018.

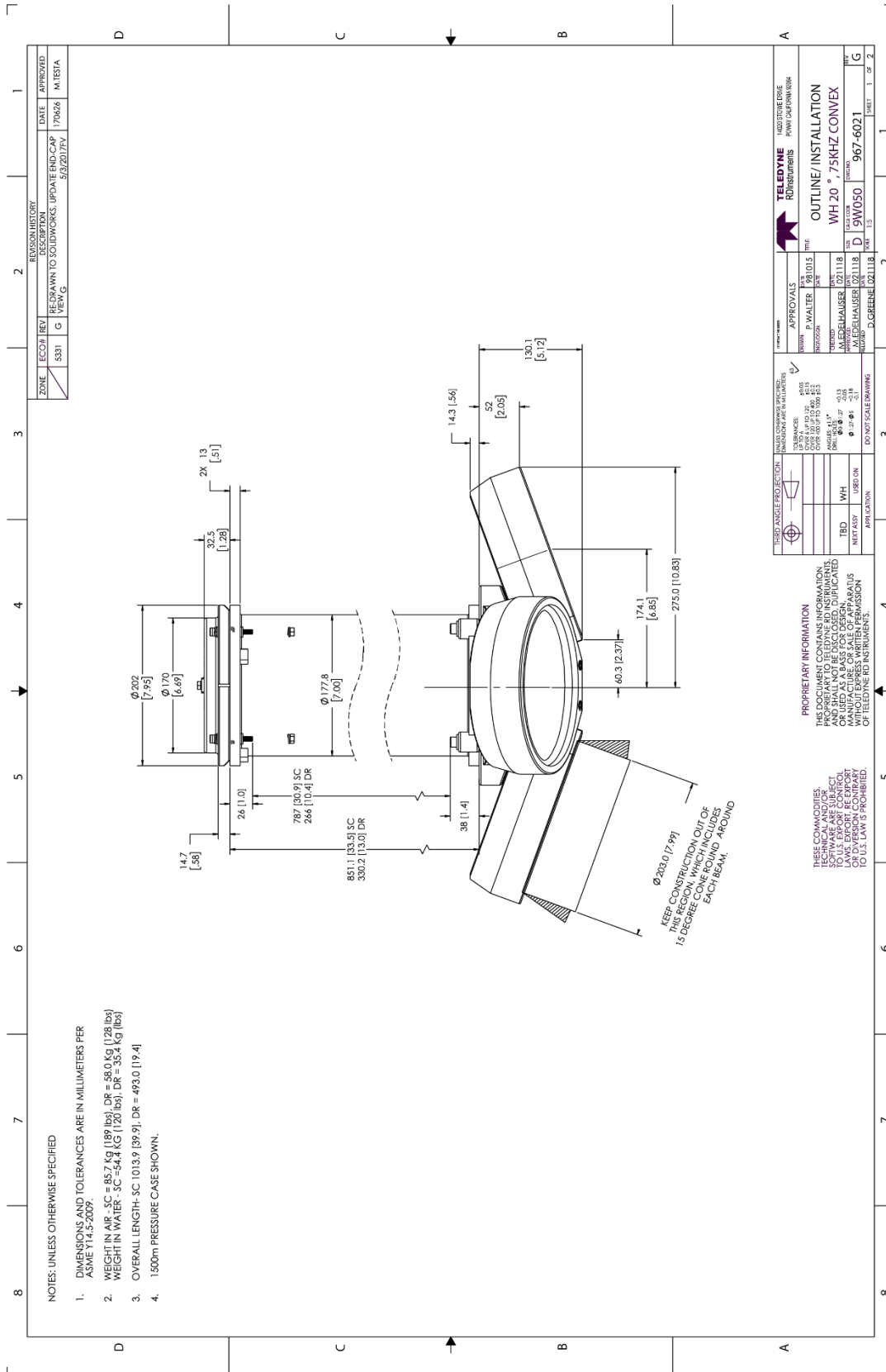

Figure 68. 967-6021 (Sheet 1 of 2)

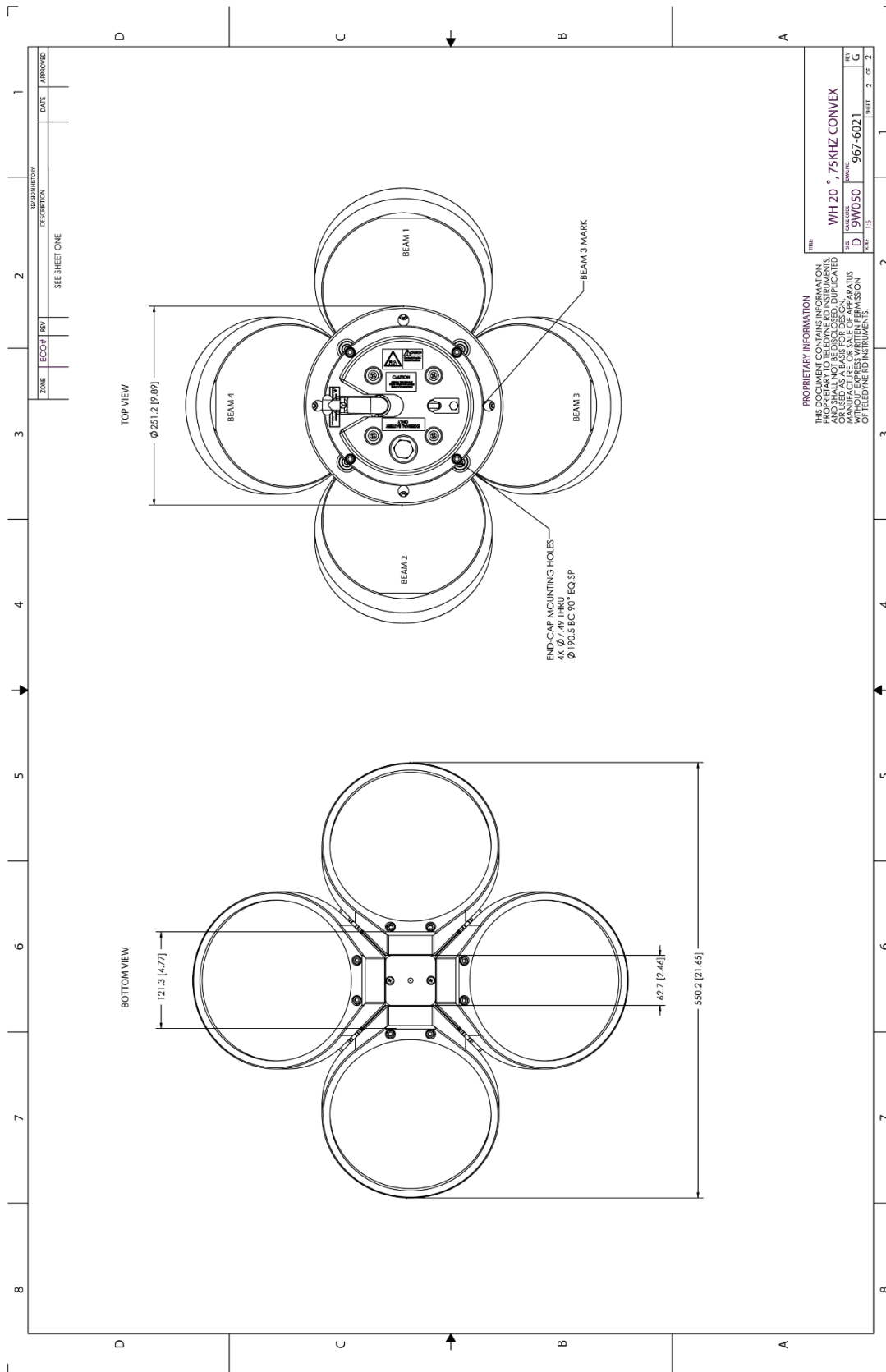

Figure 69. 967-6021 (Sheet 2 of 2)

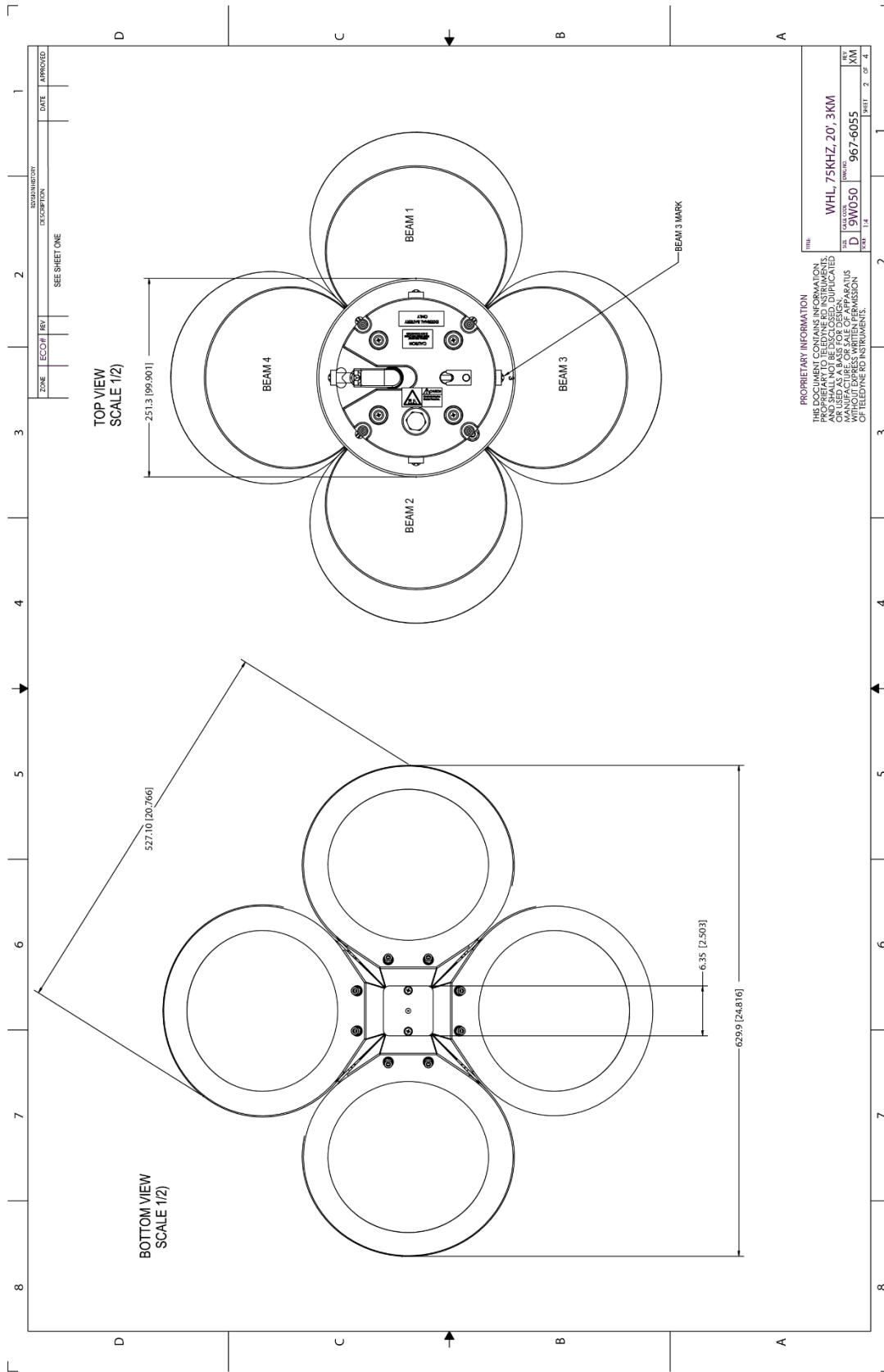

Figure 72. 967-6055 (Sheet 2 of 4)

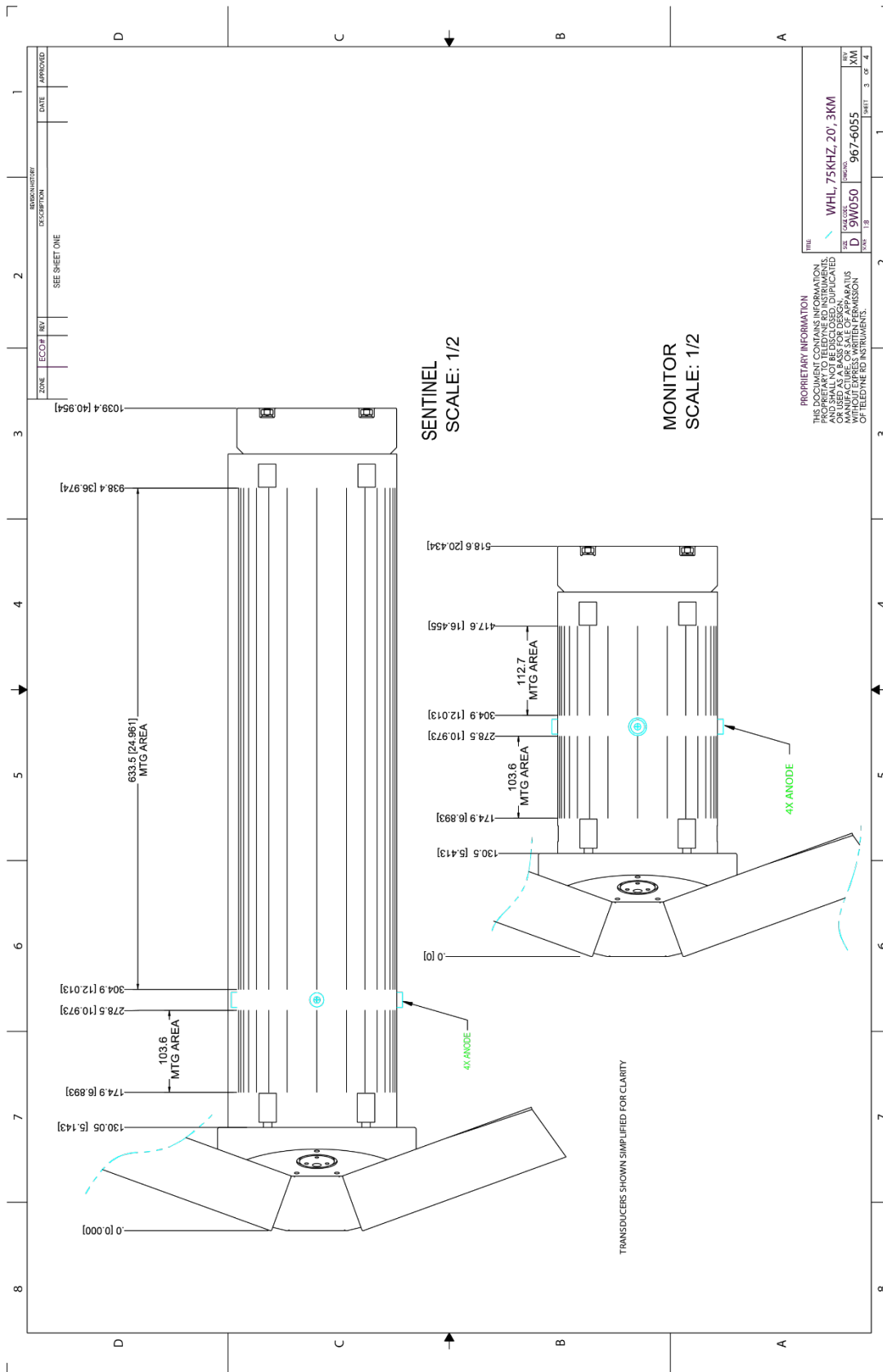

Figure 73. 967-6055 (Sheet 3 of 4)

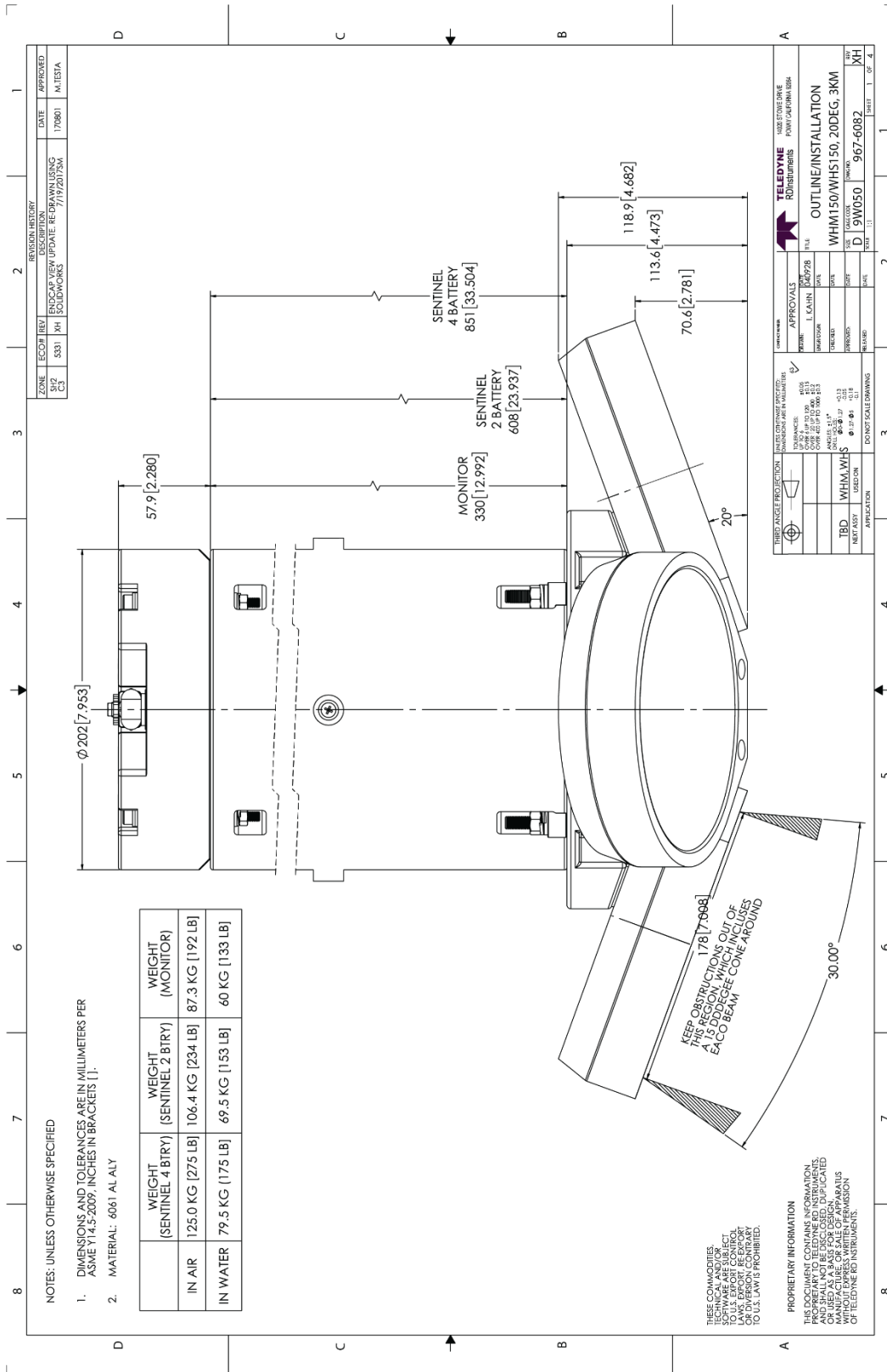

Figure 75. 967-6082, Sheet 1

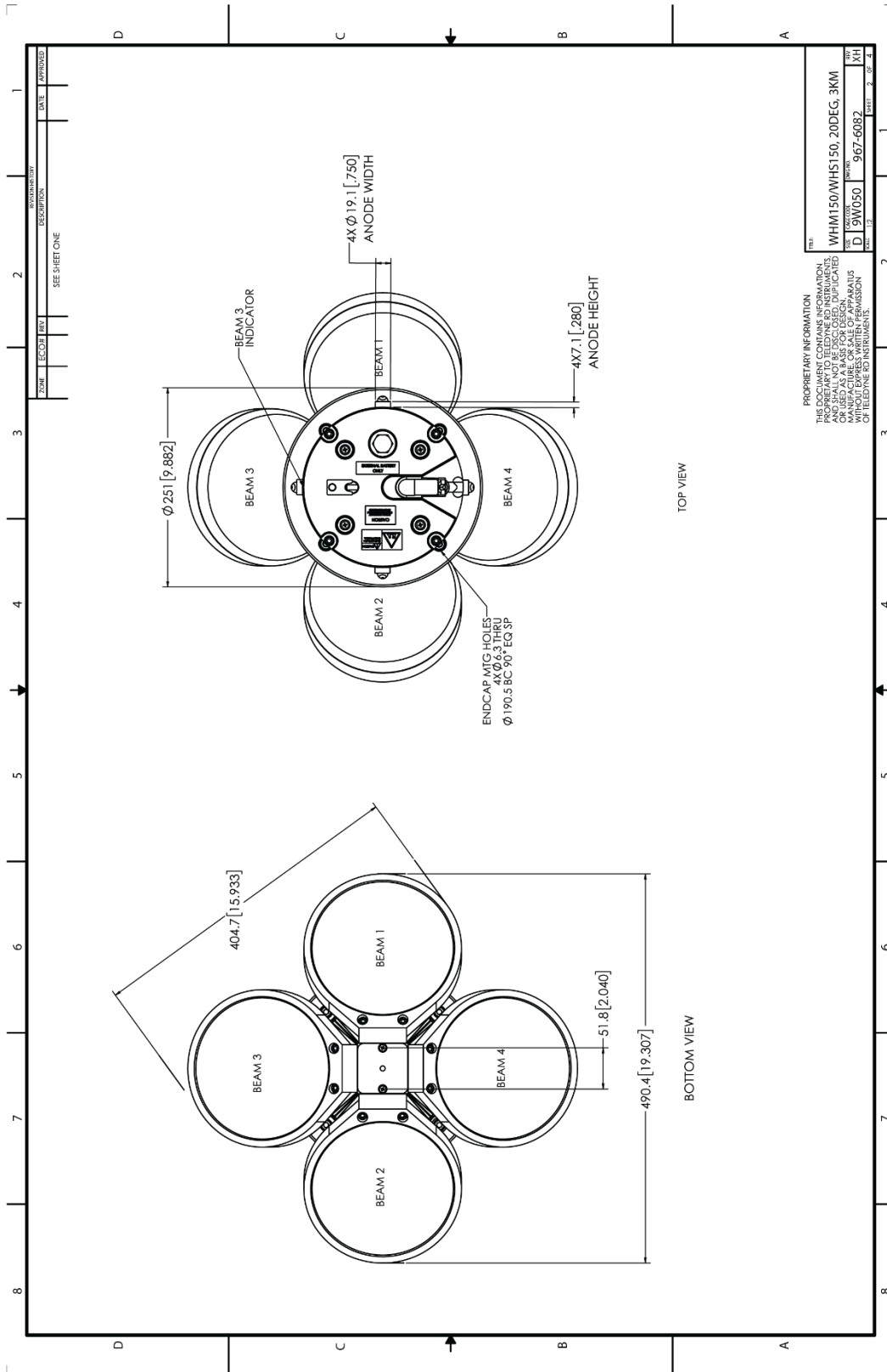

Figure 76. 967-6082, Sheet 2

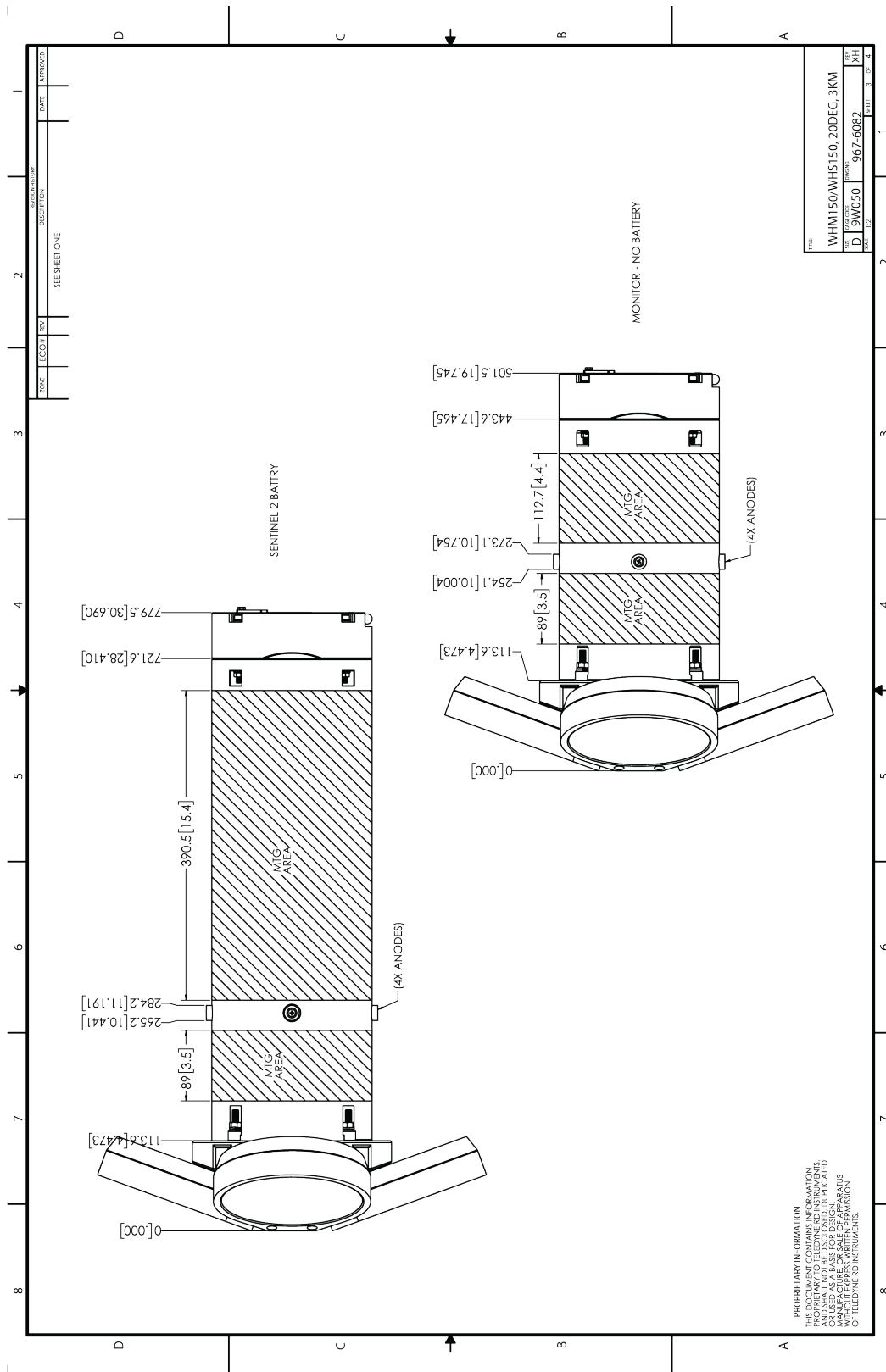

Figure 77. 967-6082, Sheet 3

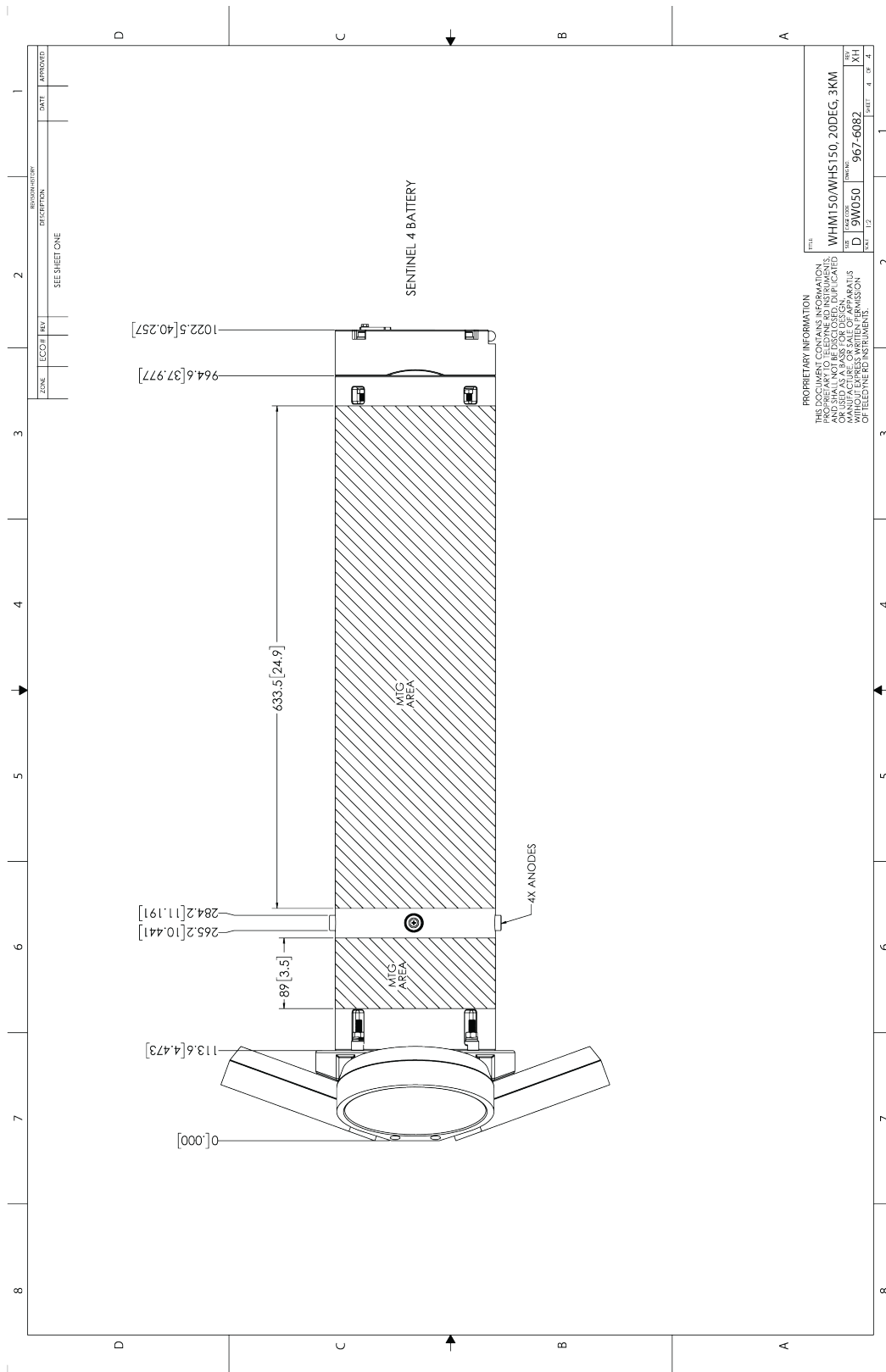

Figure 78. 967-6082, Sheet 4

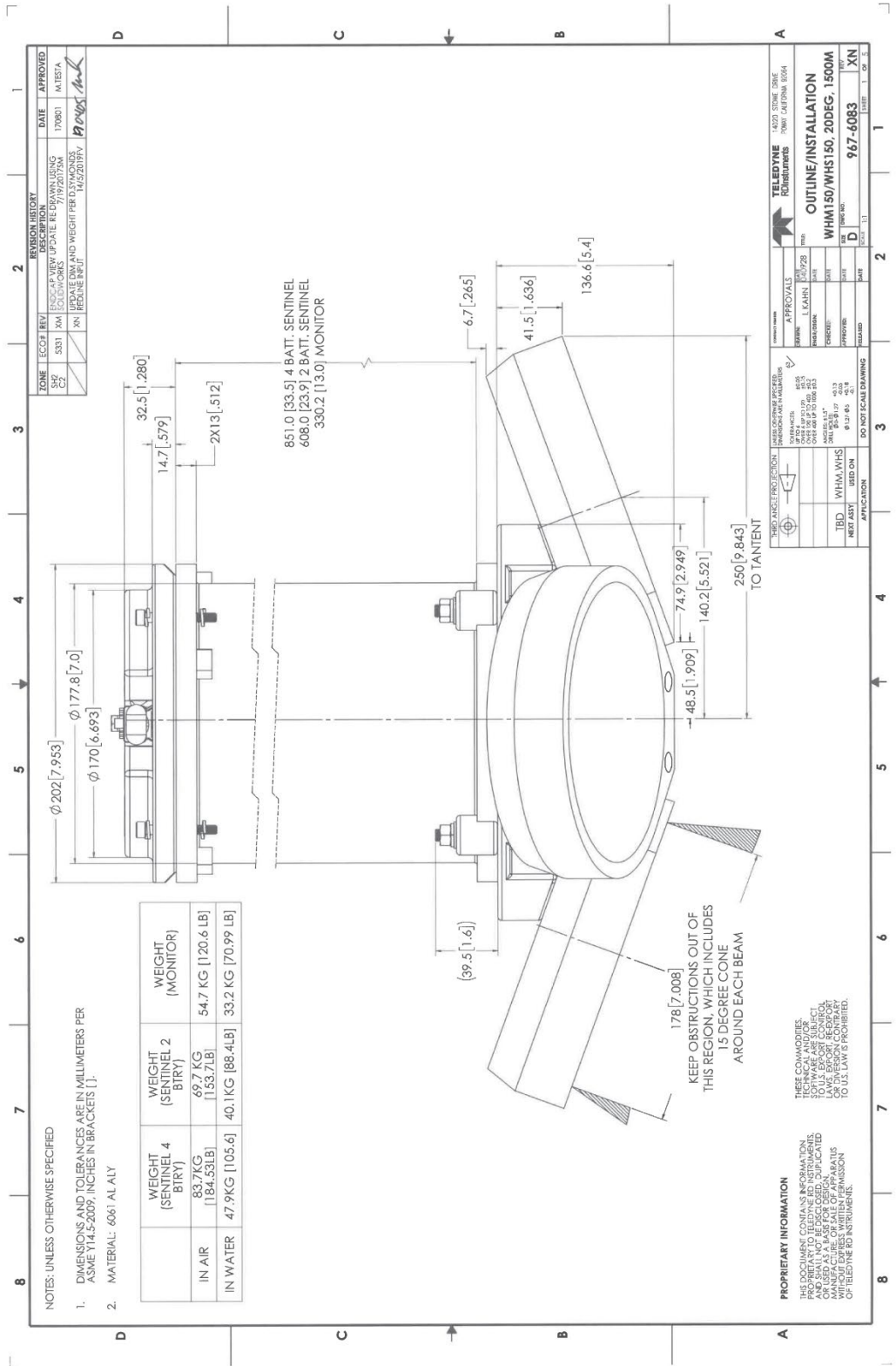

Figure 79. 967-6083, Sheet 1

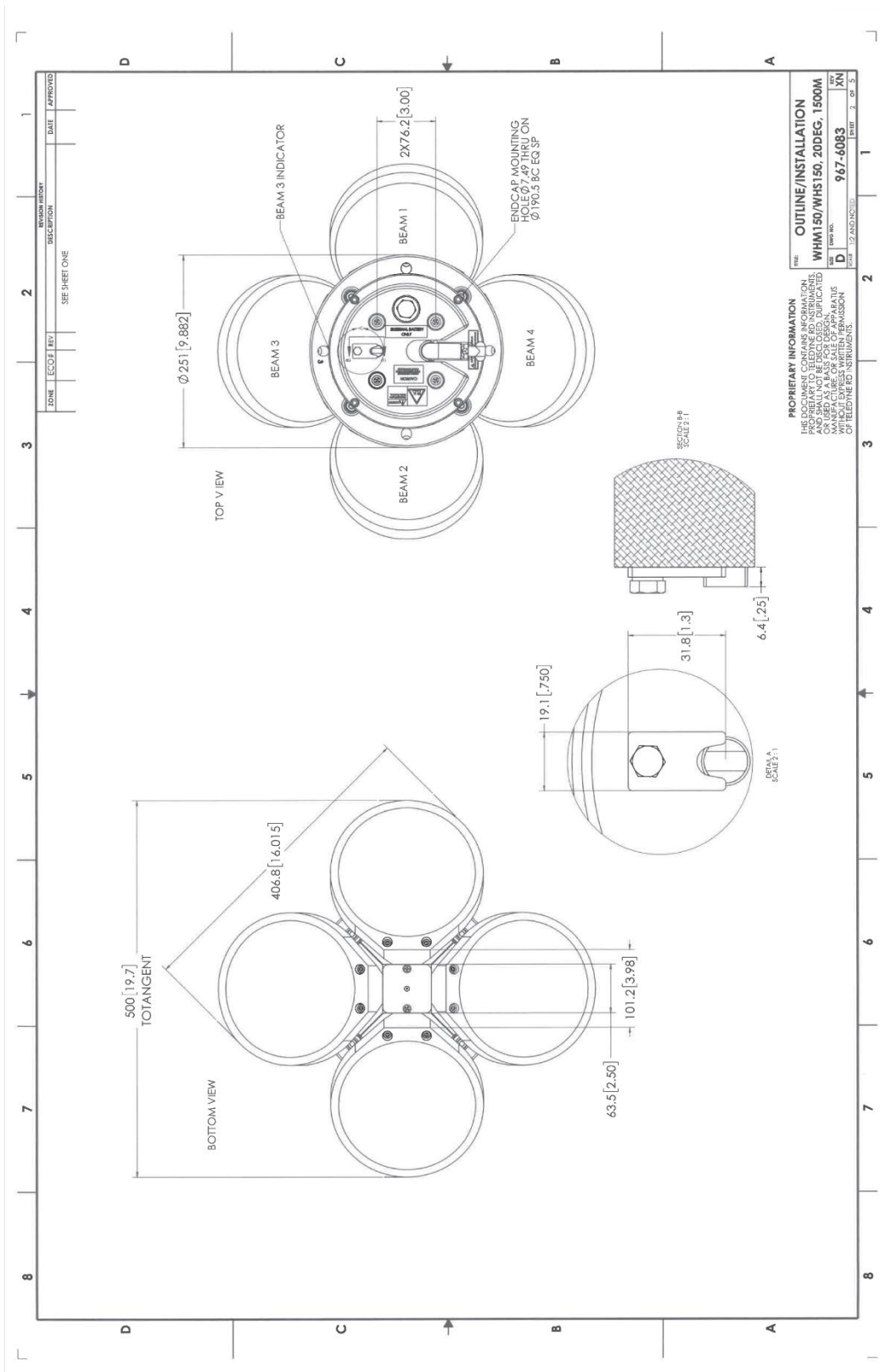

Figure 80. 967-6083, Sheet 2

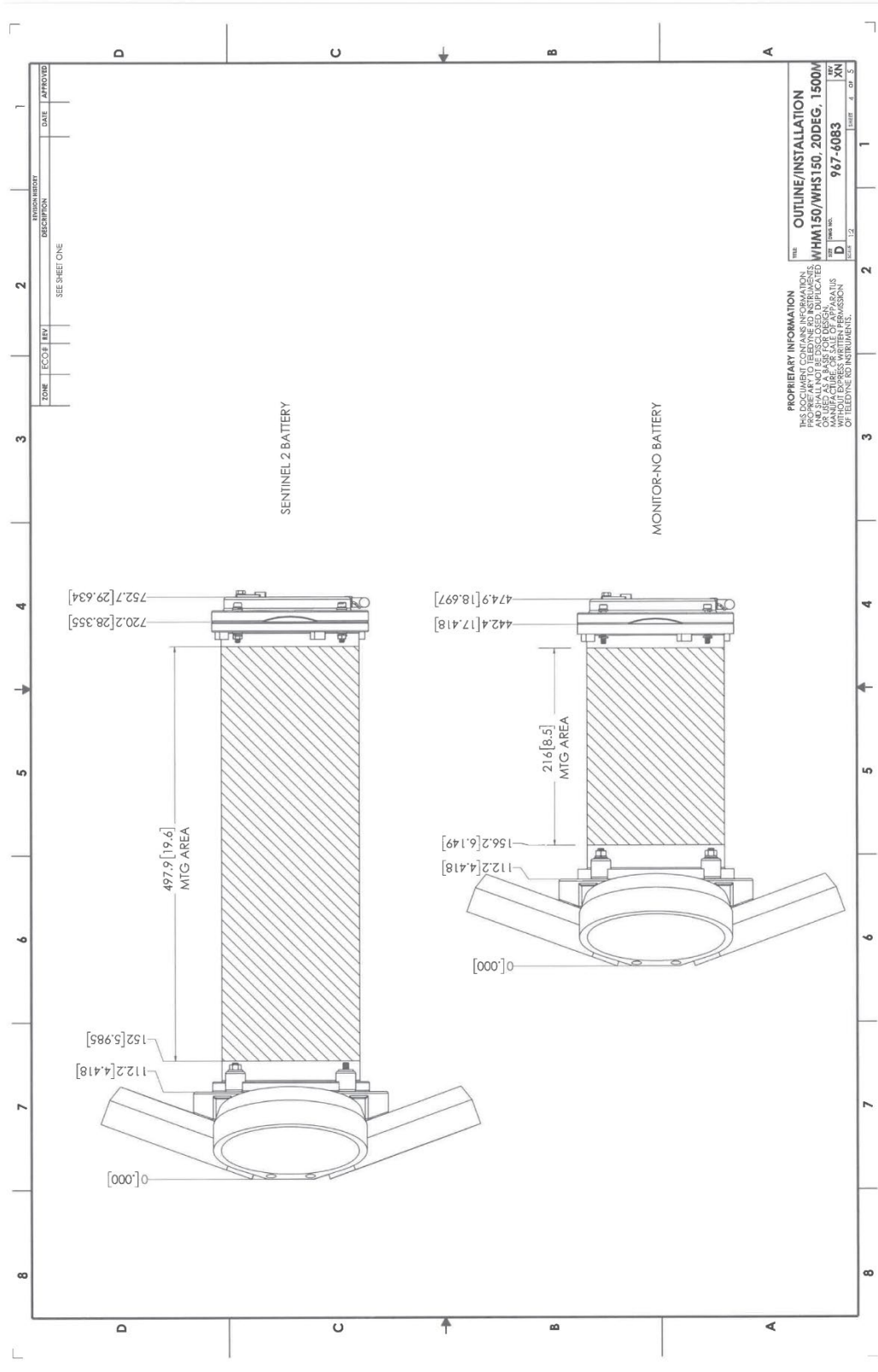

Figure 82. 967-6083, Sheet 4

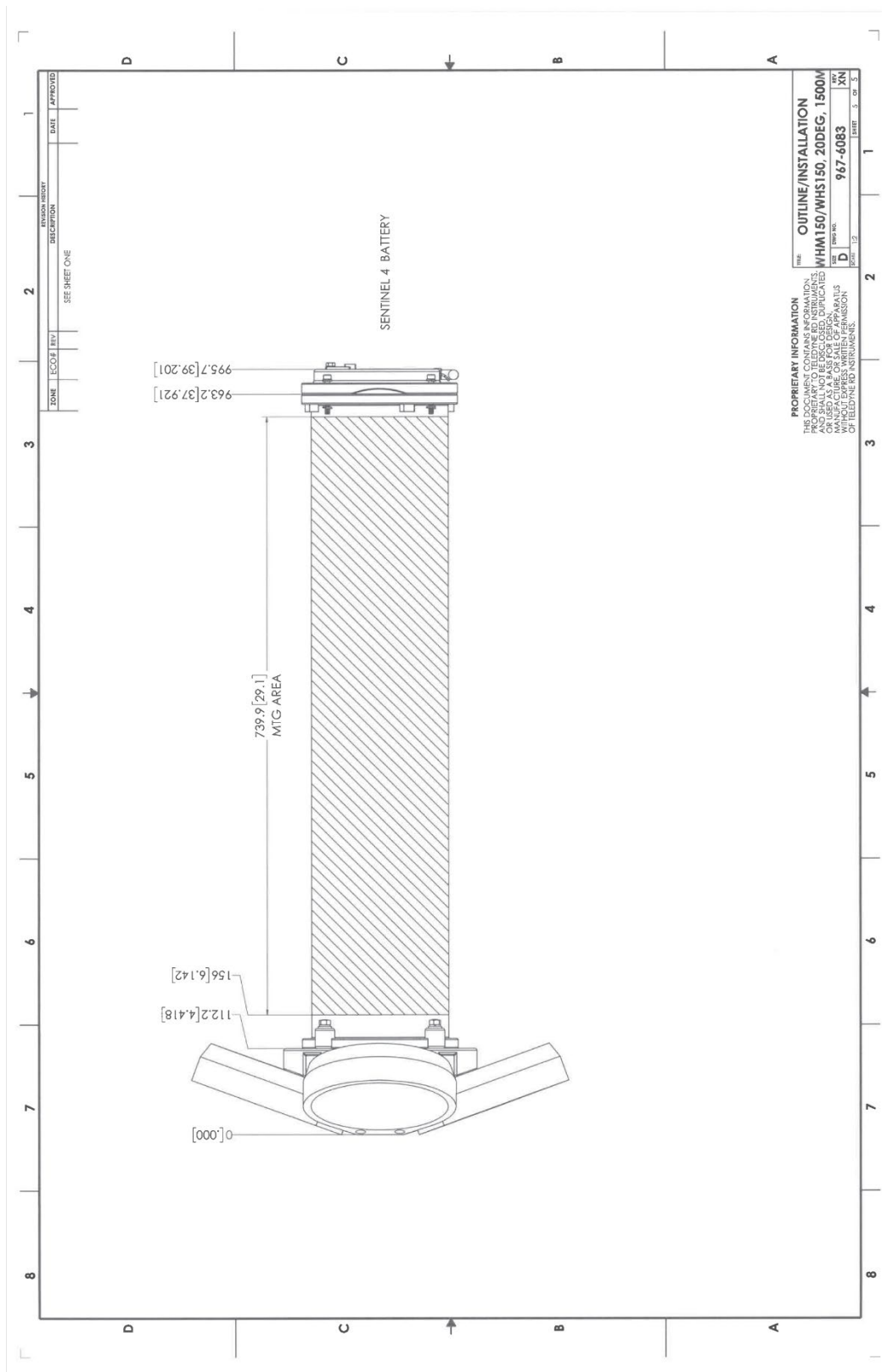

Figure 83. 967-6083, Sheet 5

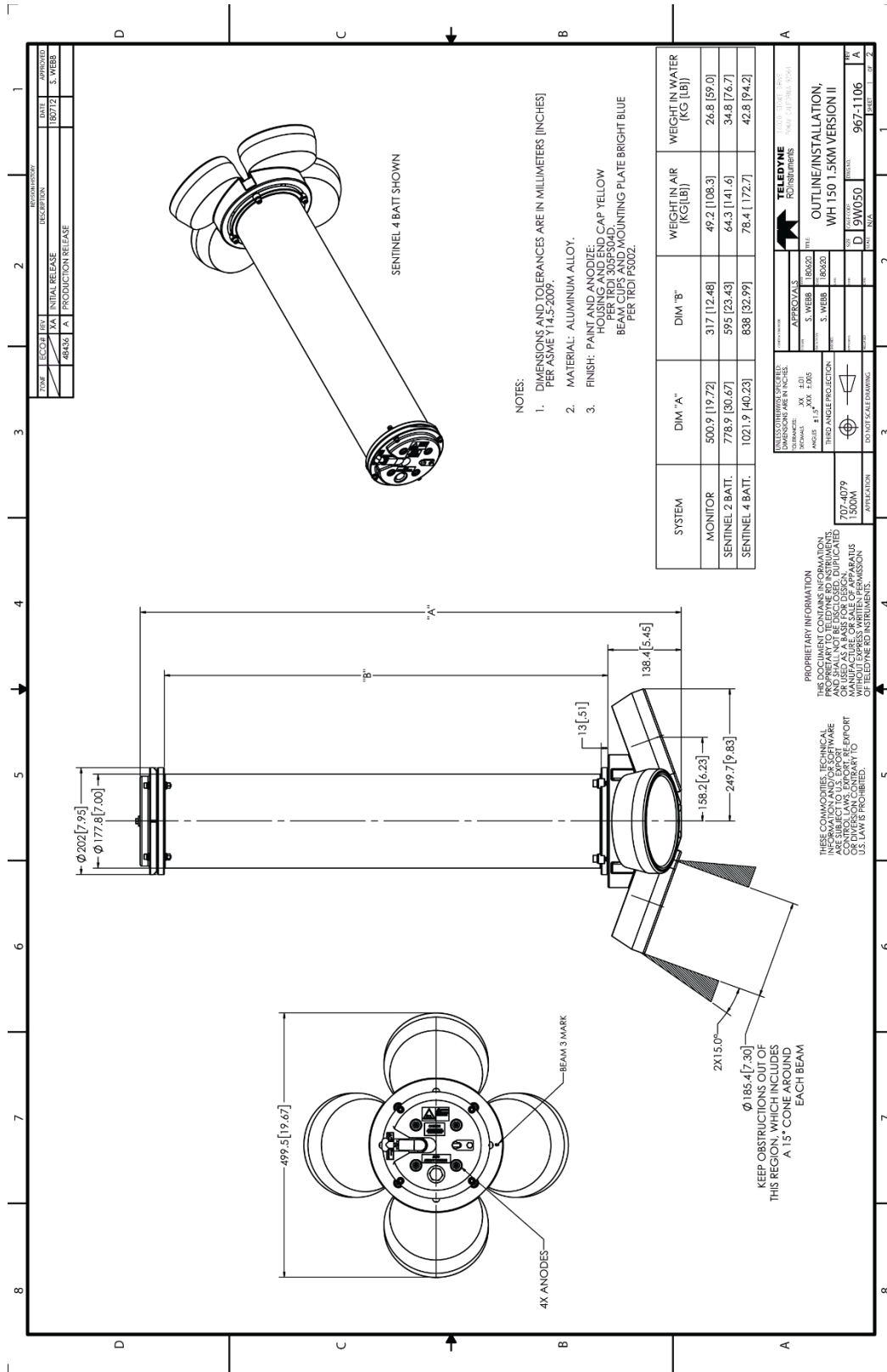

Figure 84. 967-1106, Sheet 1

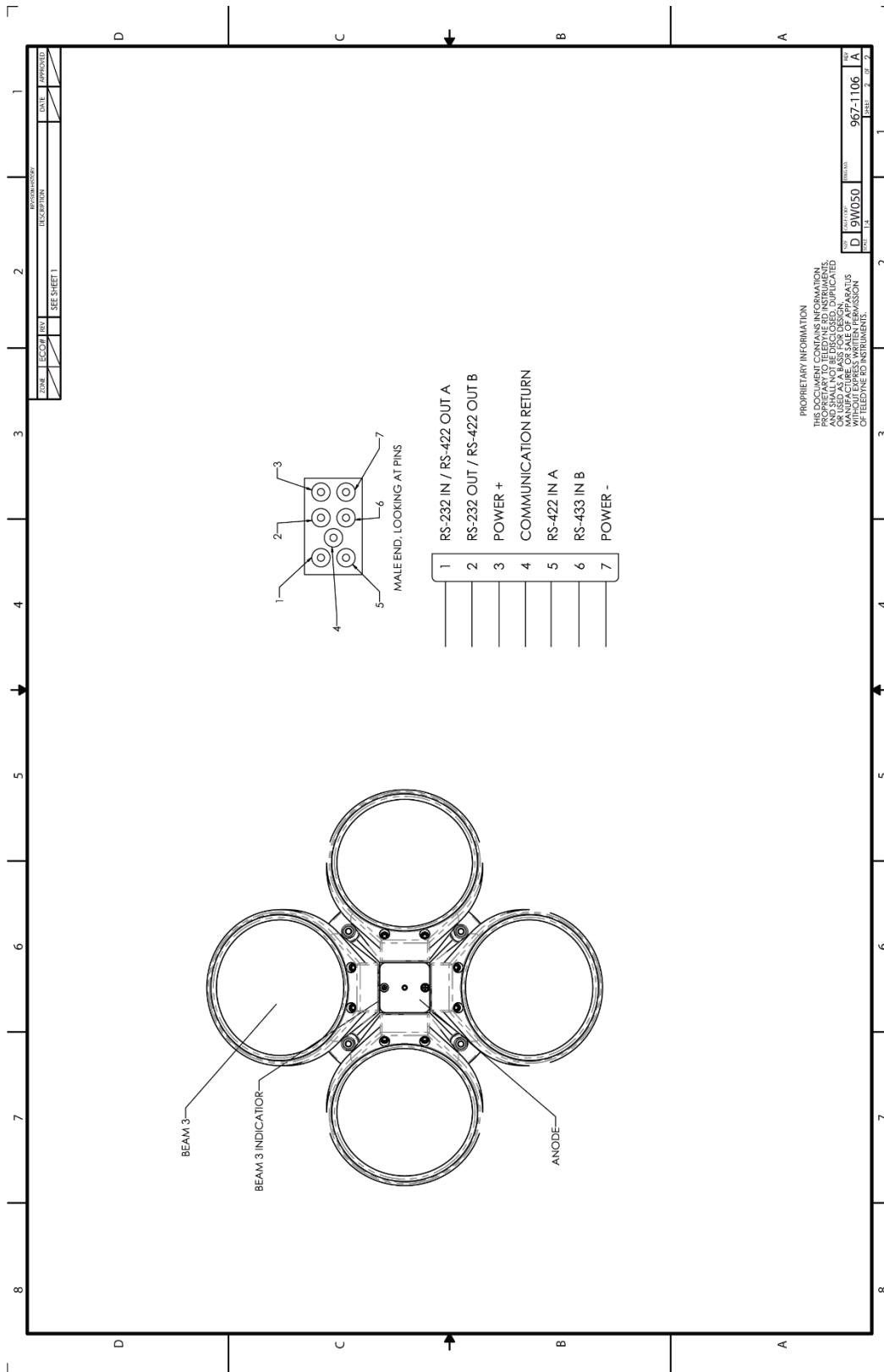

Figure 85. 967-1106, Sheet 2

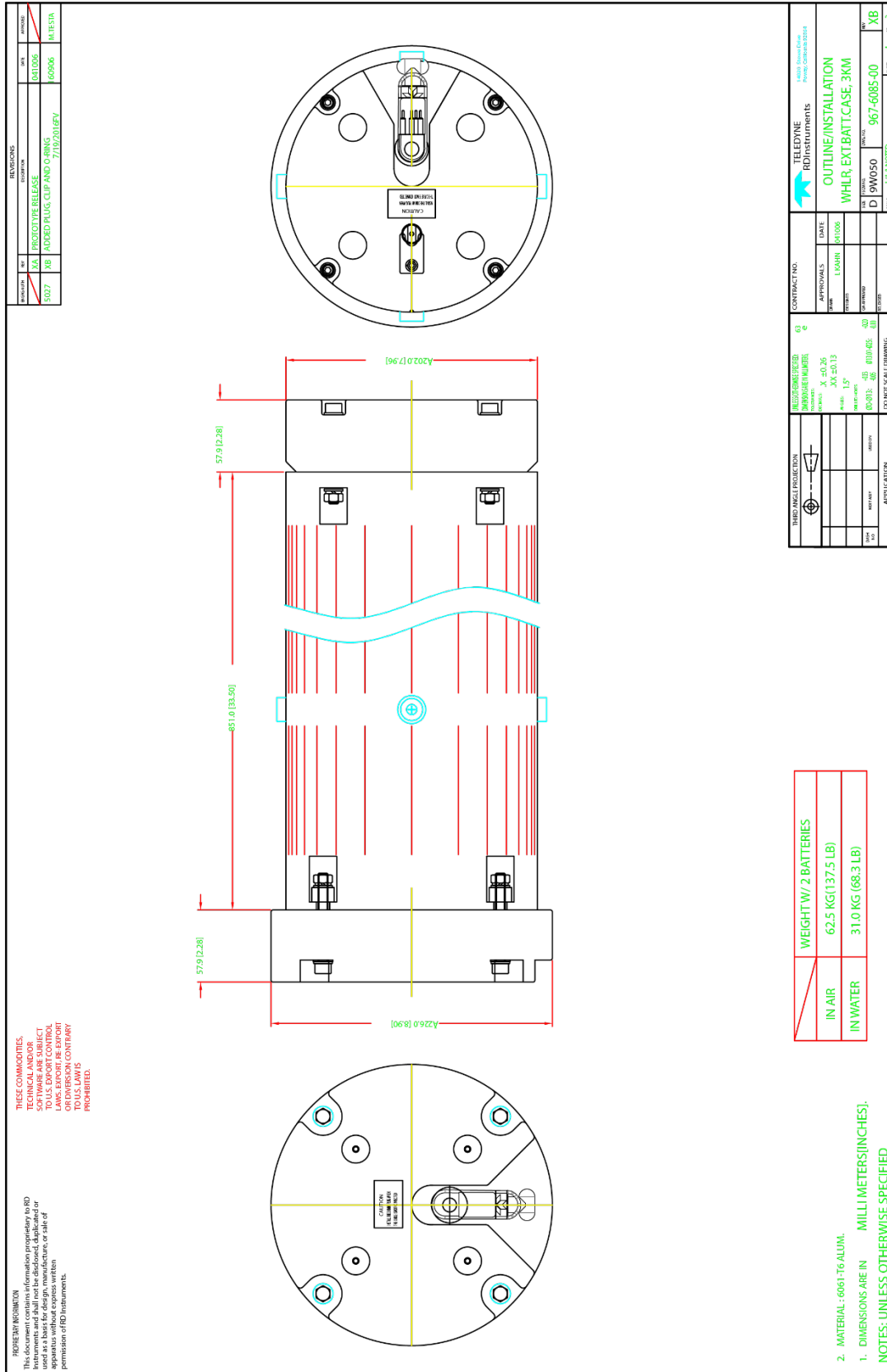

Figure 86. 967-6085, External Battery Case, 3000 Meters, Sheet 1

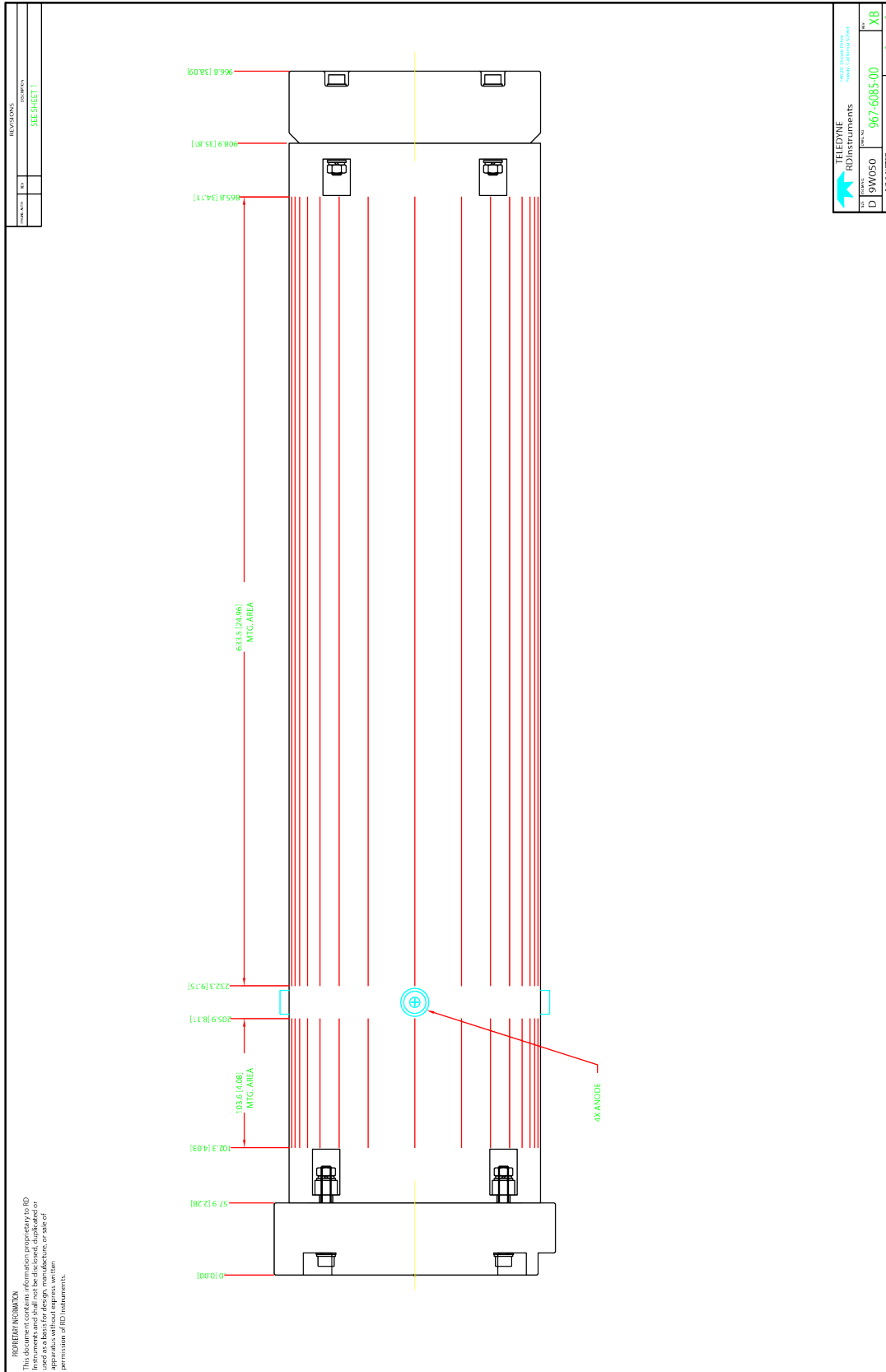

Figure 87. 967-6085, External Battery Case, 3000 Meters, Sheet 2

Appendix **A**

NOTICE OF COMPLIANCE



In this chapter, you will learn:

- China RoHS requirements
- Material disclosure table

Date of Manufacture

China RoHS requires that all Electrical and Electronic Products are marked with a Date of Manufacture. This is the starting point for the Environmental Friendly Use Period, described below.

Environmental Friendly Use Period (EFUP)

Per SJ/T 11364-2006 – Product Marking, the EFUP is defined as the time in years in which hazardous/toxic substances within Electrical and Electronic Products (EIP) will not, under normal operating conditions, leak out of the Product, or the Product will not change in such a way as to cause severe environmental pollution, injury to health, or great damage to property. TRDI has determined the Environmental Friendly Use Period shall be Ten (10) years.

The purpose of the marking is to assist in determining the restricted substance content, recyclability, and environmental protection use period of our covered products, as required in Chinese law, and does not reflect in any way the safety, quality, or warranty associated with these TRDI products.



Some homogenous substance within the EIP contains toxic or hazardous substances or elements above the requirements listed in SJ/T 11363-2006. These substances are identified in Table 17.

WEEE



The mark shown to the left is in compliance with the Waste Electrical and Electronic Equipment Directive 2002/96/EC (WEEE).

This symbol indicates the requirement NOT to dispose the equipment as unsorted municipal waste, but use the return and collection systems according to local law or return the unit to one of the TRDI facilities below.

Teledyne RD Instruments USA
14020 Stowe Drive
Poway, California 92064

Teledyne RD Instruments Europe
2A Les Nertieres
5 Avenue Hector Pintus
06610 La Gaude, France

Teledyne RD Technologies
1206 Holiday Inn Business Building
899 Dongfang Road, Pu Dong
Shanghai 20122 China

Material Disclosure Table

In accordance with SJ/T 11364-2006, the following table disclosing toxic or hazardous substances contained in the product is provided.

Table 17. Toxic or Hazardous Substances and Elements Contained in Product

零件项目(名称) Component Name	有毒有害物质或元素 Toxic or Hazardous Substances and Elements					
	铅 Lead (Pb)	汞 Mercury (Hg)	镉 Cadmium (Cd)	六价铬 Hexavalent Chromium (Cr ⁶⁺)	多溴联苯 Poly brominated Biphenyls (PBB)	多溴二苯醚 Poly brominated Diphenyl Ethers (PBDE)
换能器配件 Transducer Assy.	X	O	O	O	O	O
机体装配件 Housing Assy.	O	O	O	O	O	O
底座装配 End-Cap Assy.	X	O	O	O	O	O
接收机电路板 Receiver PCB	X	O	O	O	O	O
数据处理器电路板 DSP PCB	X	O	O	O	O	O
微处理器电路板 CPU PCB	X	O	O	O	O	O
功放电路板 High Power Amp.	X	O	O	O	O	O
高压功率组装配件 High Power Assy.	X	O	O	O	O	O
电池接口电路板 Battery Intf. PCB	X	O	O	O	O	O
交流电转换器 AC Voltage Adapter	X	O	O	O	O	O
电池组 Battery Pack	X	O	O	O	O	O
外接电池组装配件 External Battery Assy.*	X	O	O	O	O	O
水下专用电缆 Underwater Cable	X	O	O	O	O	O
专用装运箱和泡沫塑料垫 Shipping Case w/Foam	O	O	O	O	O	O

O: 表示该有毒或有害物质在该部件所有均质材料中的含量均在 SJ/T 11363-2006 标准规定的限量要求以下。

O: Indicates that the toxic or hazardous substance contained in all of the homogeneous materials for this part is below the limit required in SJ/T 11363-2006.

X: 表示该有毒或有害物质至少在该部件的某一均质材料中的含量超出 SJ/T 11363-2006 标准规定的限量要求。

X: Indicates that the toxic or hazardous substance contained in at least one of the homogeneous materials used for this part is above the limit requirement in SJ/T 11363-2006.

NOTES