

# Appendix F

## Ethernet Communication with Adaptive Sampling

Ethernet communication and interactive sampling commands are available options that provide adaptive sampling for the Sediment Trap (adaptive sampling triggers and changes sample events while the deployment is in progress). This Appendix explains the Ethernet hardware, Ethernet configuration and communication, and interactive sampling commands. Ethernet communication with adaptive sampling is available in Version PST-21E1 of the Sediment Trap firmware.

### Ethernet Hardware

A PERLE Ethernet to serial board (IOLAN-TS2) is added to the standard electronics for Ethernet communication. An external, 24V power source and connection to an Ethernet network are required to communicate with the Sediment Trap.

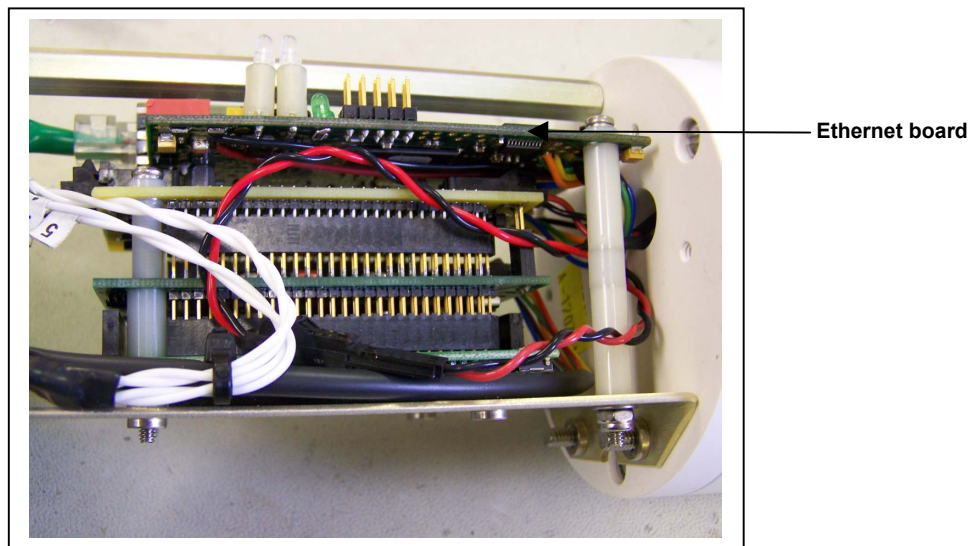

*Figure F-1: Controller Electronics Stack with Ethernet Board*

#### NOTE

If the external power is removed, the Ethernet board power will turn off and the RS232 communications will turn on. The electronics will continue to operate on the internal batteries.

## End Cap Connectors, Test Cable and Current Draw

The Ethernet/External Power bulkhead connector on the controller housing is a 6 pin MCBH(WB)-6-MP-SS connector that mates to an Impulse MCIL-6-FS cable connector. A test cable (included for bench testing - do not use for deployment) has the cable connector, an RJ45 Ethernet connector and a dual, in-line banana jack as shown in Figure F-3. Figure F-5 shows the test cable wiring diagram. The external power source must be 24V DC, capable of 750mA (minimum) (not to exceed 30VDC). Current draw is 70 mA (motor off) and 350 mA (motor on).

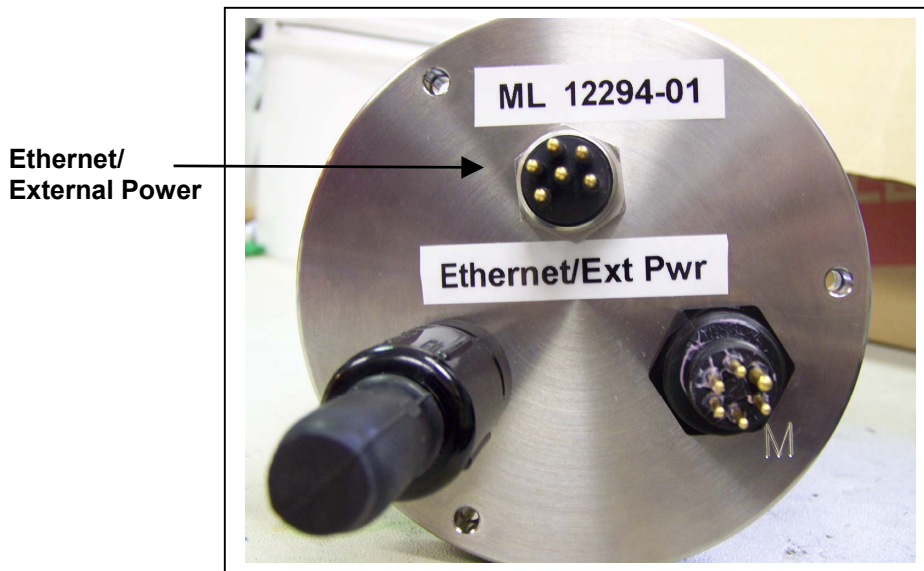

*Figure F-2: Test Cable Wiring Diagram*

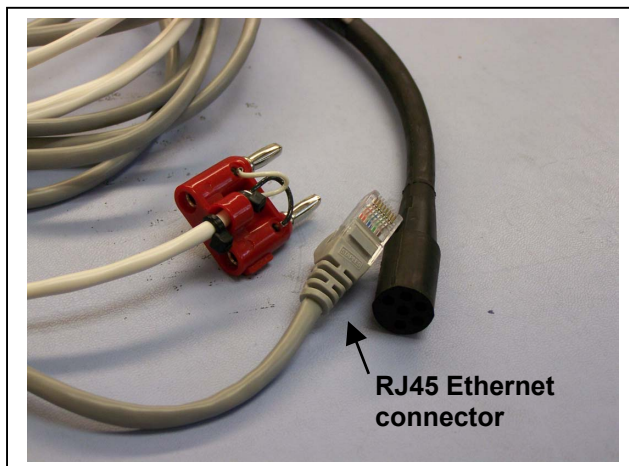

*Figure F-3: Test Cable Connectors*

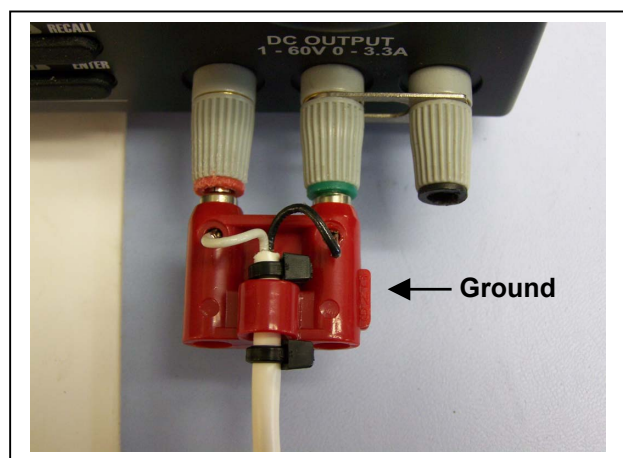

*Figure F-4: Test Cable Dual In-Line Banana Jack*

Test Cable Wiring Diagram

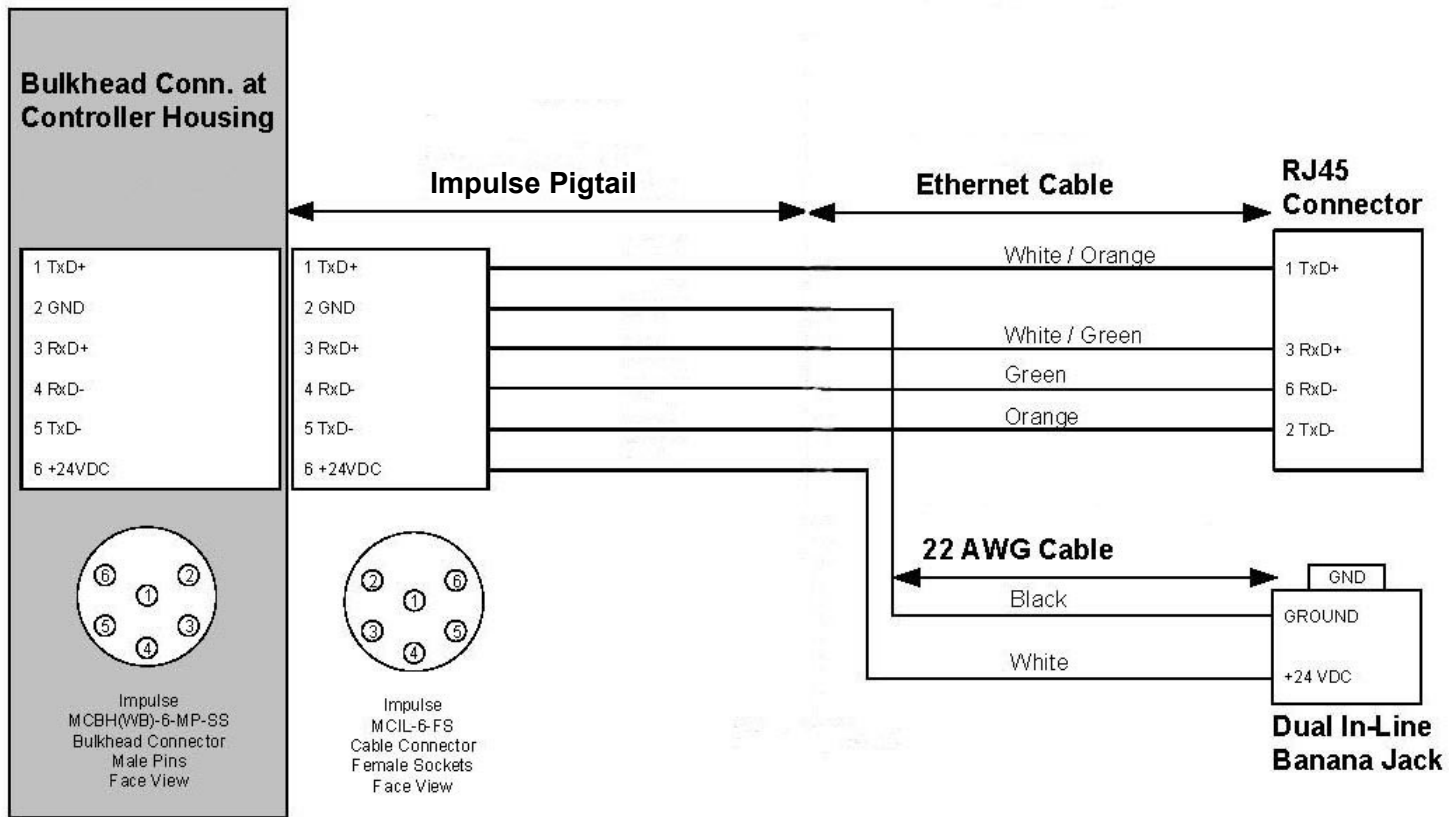

Figure F-5: Test Cable Wiring Diagram

## Ethernet Configuration

The Ethernet board can be configured using the PERLE software on the CD-ROM included with the Sediment Trap. The factory settings are shown in the Web Browser Interface (Figure F-6).

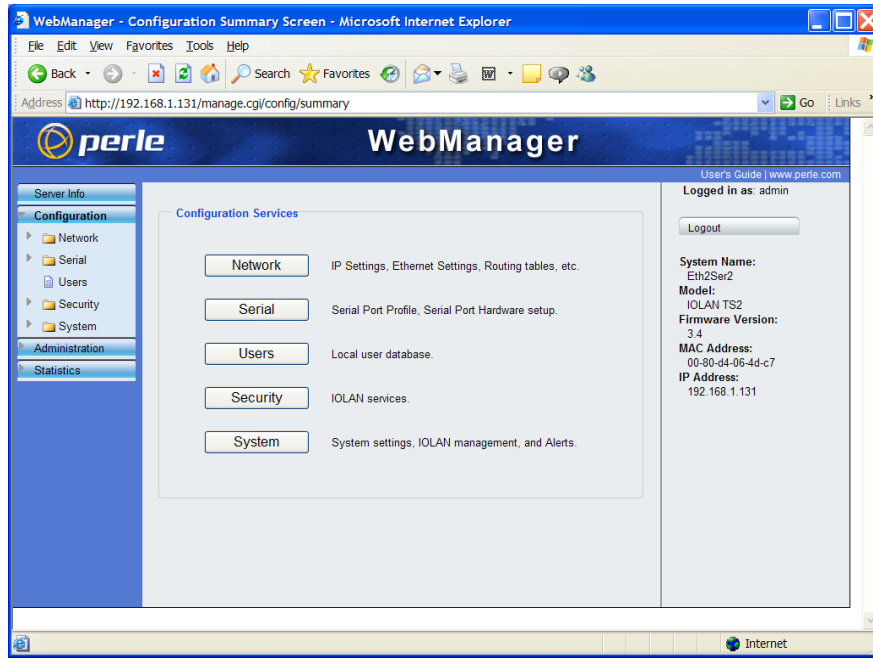

Figure F-6: Web Interface to Ethernet Board

## Ethernet Communication

Once configured, the Ethernet board will accept raw TCP/IP commands and pass them to the Sediment Trap firmware. The TCP/IP communication module would include the following components:

1. Establish the TCP/IP connection with the controller IP Address and port (10001).
2. Send commands using a TCP Transmit command.
3. Receive data using a TCP Read command.
4. Disconnect using a TCP Close command.

Matlab, LabVIEW, and many C compilers include raw TCP/IP example code.

There are two COM ports on the Ethernet board. COM Port 1 is used for communication (Ethernet Port 10001), COM Port 2 (Ethernet Port 10002) is used to reboot the electronics if emergency recovery is required.

### IMPORTANT

Connecting to Ethernet Port 10002, automatically reboots the electronics.

## Interactive Sampling Commands

Adaptive sampling occurs after the Sediment Trap has been deployed. First, prepare for deployment by connecting the serial COM cable and battery pack. Use Chapter 7, “Sediment Trap User Interface” to program sample events and put the firmware in low power sleep.

### Using Interactive Sampling Commands

Once deployed, the Sediment Trap sample events can be changed via the Ethernet communication protocol. Communicating with the Sediment Trap during deployment allows the operator to adapt the sampling schedule in real-time. To use the interactive commands, complete the following steps:

1. Begin terminal emulation and confirm that the firmware is in low power sleep.
2. Press any key to display a prompt (available only when the firmware is in low power sleep during the deployment).

```
05/15/2008 09:59:03 sleeping . . .  
ML12294-02 > ← Prompt for interactive commands contains the sampler serial number
```

*Figure F-7: Prompt for Interactive Commands*

### NOTE

The ‘ML’ in the prompt indicates ‘McLane Labs’, followed by the sampler serial number. The serial number is a unique identifier for each sampler.

- Type an interactive command to communicate with the firmware (15 seconds of typing inactivity deactivates the prompt, pressing any key reactivates the prompt).

## NOTE

After executing an interactive command, the system returns to low power sleep to wait for the next sample event or the next interactive command.

### ST - Current Status

The 'ST' command displays Event #, confirms rotator alignment, shows electronics temperature in °C, battery voltage, previous sample date/time, current date/time, next sample date/time (shown in Figure F-8).

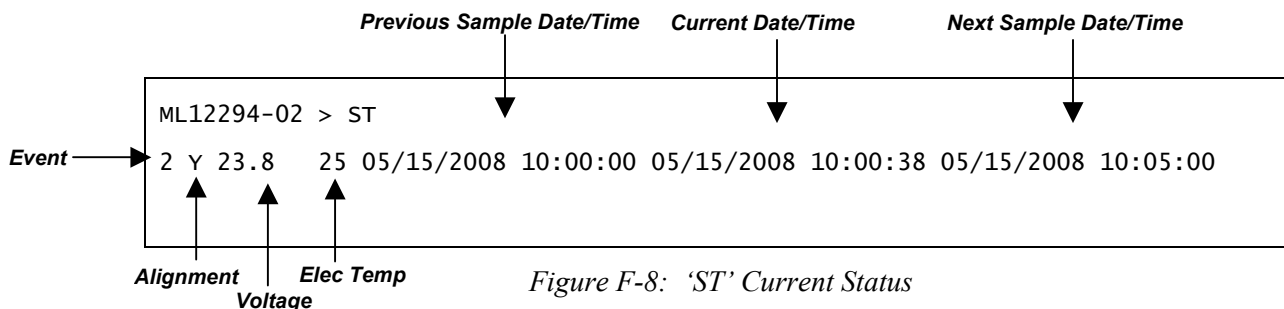

### RB - Rotate Bottle

'RB' Rotate Bottle commands the firmware to rotate to the next bottle. There is a 5 minute delay between the command and the rotation to allow the user to make corrections. As shown in Figure F-9, no other events are changed. A status line is returned to show the change.

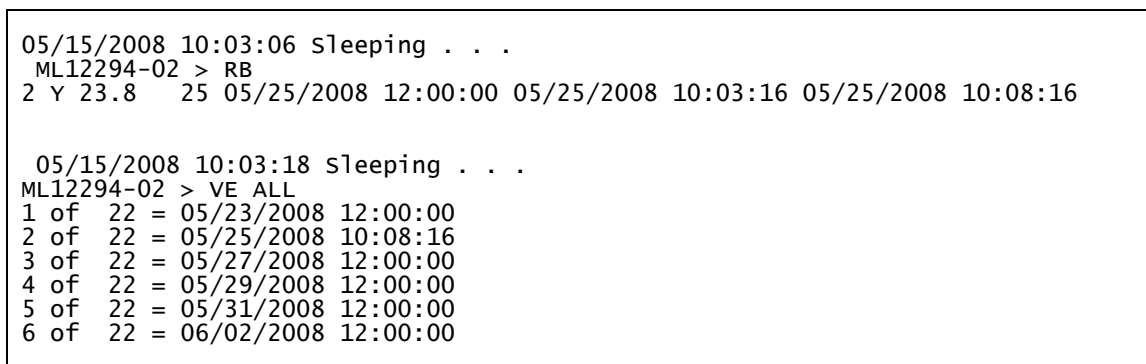

## VE - View Event

'VE' View event shows the pending sample event number, date/time of rotation as shown in Figure F-10.

```
05/15/2008 10:00:40 sleeping . . .
ML12294-02 > VE
2 05/15/2008 10:05:00
```

*Figure F-10: 'VE' View Event*

## VE n - View Event Number

'VE n' View event number shows the number, date/time scheduled for the specified event as shown in Figure F-11.

```
05/15/2008 10:01:04 sleeping . . .
ML12294-02 > VE 20 ← Show sample event #20
20 05/15/2008 11:35:00
```

*Figure F-11: 'VE n' View Specific Event*

## VE All - View Event All

'VE ALL' View Event All shows the number, date/time for all scheduled events as shown in Figure F-12.

```
05/15/2008 10:01:48 sleeping . . .
ML12294-02 > VE ALL
1 05/15/2008 10:00:00
2 05/15/2008 10:05:00
3 05/15/2008 10:10:00
4 05/15/2008 10:15:00
5 05/15/2008 10:20:00
6 05/15/2008 10:25:00
7 05/15/2008 10:30:00
8 05/15/2008 10:35:00
9 05/15/2008 10:40:00
10 05/15/2008 10:45:00
11 05/15/2008 10:50:00
12 05/15/2008 10:55:00
13 05/15/2008 11:00:00
14 05/15/2008 11:05:00
15 05/15/2008 11:10:00
16 05/15/2008 11:15:00
17 05/15/2008 11:20:00
18 05/15/2008 11:25:00
19 05/15/2008 11:30:00
20 05/15/2008 11:35:00
21 05/15/2008 11:40:00
22 05/15/2008 11:45:00
```

*Figure F-12: 'VE ALL' View All Events*

## CE n Date Time - Change Event Number Scheduled Start

'CE n Date/Time' changes an event scheduled start. Each parameter is separated by a space, and the format is Event #, MM DD YYYY HH MM SS. In Figure F-13, sample event #4 is changed to 5-15-2008 at 10:14:00. The system returns to low power sleep.

```

      MM DD YYYY
      Event#
      HH MM SS
      ↓
      ↓
      ↓
ML12294-02 > CE 4 05 15 2008 10 14 00
4 05/15/2008 10:14:00
05/15/2008 10:11:48 sleeping . . .
```

Figure F-13: 'CE # Date/Time' Change Event Number Scheduled Start

## DM - Display Main Menu

'DM' suspends the deployment and displays the Main Menu. In the course of normal operations, use of this menu will not be required (commands to view, change and execute events are included in the interactive commands ST, VE, CE and RB). Descriptions of the Main Menu commands are included in this appendix as a reference.

```

05/15/2008 10:14:28 sleeping . . .
ML12294-02 > DM
<05/15/2008 10:14:39> Deployment terminated by operator.
-----
McLane Research Laboratories, USA
ParFlux 21-Cup Sediment Trap
Version: PST-21E1.c S/N: ML12294-02
-----
Main Menu
-----
Thu May 15 10:14:39 2008
<1> Set Time           <5> Change Schedule
<2> Diagnostics       <6> Resume Deployment
<3> Fill Containers   <7> Offload Data
<4> Sleep             <8> Contacting McLane
selection ?
```

Figure F-14: 'DM' Display Menu

All Main Menu options can be selected to interact with the Sediment Trap.



## IMPORTANT

<6> 'Resume Deployment' must be selected to resume the deployment. If the electronics is allowed to sleep from the Main Menu, it will continue to sleep. No further events will execute.

In the course of normal operations, use of this menu will not be required. Commands to view, change and execute events are included in the interactive commands – 'ST', 'VE', 'CE', 'RB'.

### <3> - Fill Containers

The preferred method for triggering a sample is to use the interactive sampling command 'RB' while in a deployment. Selecting <3> Fill Containers triggers on demand sample events. The previous scheduled time for the sample event is overridden and the sample bottle is rotated immediately.

```
05/15/2008 10:14:28 sleeping . . .
ML12294-02 > DM
<05/15/2008 10:14:39> Deployment terminated by operator.

McLane Research Laboratories, USA
ParFlux 21-Cup Sediment Trap
Version: PST-21E1.c S/N: ML12294-02

Main Menu

Thu May 15 10:14:39 2008

<1> Set Time           <5> Change Schedule
<2> Diagnostics       <6> Resume Deployment
<3> Fill Containers   <7> Offload Data
<4> Sleep             <8> Contacting McLane

Selection ? 3
Rotator is aligned.
Next Bottle (Yes/No) [N] ? y

<05/15/2008 10:18:31> Filling bottle - overriding event #06 . . .
Moving rotator assembly . . . rotor aligned.
Lowest battery detected = 23.8 V

Rotator is aligned.
Next Bottle (Yes/No) [N] ?
```

Figure F-15: <3> Fill Containers

## <5> - Change Schedule

The preferred method for changing events is using the 'CE' command while in a deployment. Selecting <5> Change Schedule displays the Schedule Menu. Typing 'Y' at the prompt displays the Sample Schedule Menu.

```
05/15/2008 10:14:28 sleeping . . .
ML12294-02 > DM

<05/15/2008 10:14:39> Deployment terminated by operator.

-----
McLane Research Laboratories, USA
ParFlux 21-Cup Sediment Trap
Version: PST-21E1.c S/N: ML12294-02

-----
Main Menu
-----
Thu May 15 10:14:39 2008

<1> Set Time           <5> Change Schedule
<2> Diagnostics       <6> Resume Deployment
<3> Fill Containers   <7> Offload Data
<4> Sleep             <8> Contacting McLane

selection ? 5
8 events have already triggered. ← Number of completed sample events
These events will be preserved in the deployment schedule.
14 events which have not triggered will be erased.
Continue (Yes/No) [N] ? y
Change deployment schedule (Yes/No) [N] ? y ← Type Y to change schedule
14 pending events removed from deployment schedule.
Enter the number of events to program (0 to 14) ? 14

-----
SCHEDULE MENU
-----
<1> Enter each event time
<2> Enter start date & interval
<3> Enter start date & end date
<M> Main Menu
selection ? 2
```

Figure F-16: <5> Change Schedule (screen 1 of 2)

Select a method for changing the schedule (enter each event time, or enter a start date and interval or specify start and end dates). In Figure F-17, the start interval is changed to 2 days.

```
Enter START date and time [05/23/2008 11:15:06] ? 5 23 2008 12 00 00
Enter interval
  Days      (0 to 365) ? 2
  Hours     (0 to 23) ? 00
  Minutes   (0 to 59) ? 00
Schedule Verification
Event  1 of 22 = 05/23/2008 12:00:00 (already triggered)
Event  2 of 22 = 05/25/2008 12:00:00 (already triggered)
Event  3 of 22 = 05/27/2008 12:00:00 (already triggered)
Event  4 of 22 = 05/29/2008 12:00:00 (already triggered)
Event  5 of 22 = 05/31/2008 12:00:00 (already triggered)
Event  6 of 22 = 06/02/2008 12:00:00 (already triggered)
Event  7 of 22 = 06/04/2008 12:00:00 (already triggered)
Event  8 of 22 = 06/06/2008 12:00:00 (already triggered)
Event  9 of 22 = 06/08/2008 12:00:00
Event 10 of 22 = 06/10/2008 12:00:00
Event 11 of 22 = 06/12/2008 12:00:00
Event 12 of 22 = 06/14/2008 12:00:00
Event 13 of 22 = 06/16/2008 12:00:00
Event 14 of 22 = 06/18/2008 12:00:00
Event 15 of 22 = 06/20/2008 12:00:00
Event 16 of 22 = 06/22/2008 12:00:00
Press any key to continue.

Event 17 of 22 = 06/24/2008 12:00:00
Event 18 of 22 = 06/26/2008 12:00:00
Event 19 of 22 = 06/28/2008 12:00:00
Event 20 of 22 = 06/30/2008 12:00:00
Event 21 of 22 = 07/02/2008 12:00:00
Event 22 of 22 = 07/04/2008 12:00:00

Modify an event (Yes/No) [N] ?
```

Figure F-17: <5> Change Schedule (screen 2 of 2)

**NOTE**

Completed sample events cannot be changed as shown in Figure F-18.

```
Modify an event (Yes/No) [N] ? y
Enter the event number (1 to 22) ?
Enter the event number (1 to 22) ? 1
That event has already triggered and cannot be modified
```

Figure F-18: <5> Cannot Change Completed Event

Typing 'N' displays the Main Menu. Select <6> to resume the deployment. The schedule re-displays for verification, shows the system status and returns the system to low power sleep to wait for the next scheduled event.

## IMPORTANT

<6> 'Resume Deployment' must be selected to resume the deployment.

```

                                Main Menu
                                Thu May 15 10:28:03 2008
<1> Set Time                    <5> Change Schedule
<2> Diagnostics                 <6> Resume Deployment
<3> Fill Containers             <7> Offload Data
<4> Sleep                       <8> Contacting McLane

Selection ? 6
Schedule Verification
Event 1 of 22 = 05/15/2008 10:00:00 (already triggered)
Event 2 of 22 = 05/15/2008 10:08:16 (already triggered)
Event 3 of 22 = 05/15/2008 10:10:00 (already triggered)
Event 4 of 22 = 05/15/2008 10:14:00 (already triggered)
Event 5 of 22 = 05/15/2008 10:20:00 (already triggered)
Event 6 of 22 = 05/15/2008 10:25:00 (already triggered)
Event 7 of 22 = 05/15/2008 10:30:00 (already triggered)
Event 8 of 22 = 05/15/2008 10:35:00 (already triggered)
Event 9 of 22 = 05/15/2008 10:30:00
Event 10 of 22 = 05/15/2008 10:32:00
Event 11 of 22 = 05/15/2008 10:34:00
Event 12 of 22 = 05/15/2008 10:36:00
Event 13 of 22 = 05/15/2008 10:38:00
Event 14 of 22 = 05/15/2008 10:40:00
Event 15 of 22 = 05/15/2008 10:42:00
Event 16 of 22 = 05/15/2008 10:44:00
Press any key to continue.
Event 17 of 22 = 05/15/2008 10:46:00
Event 18 of 22 = 05/15/2008 10:48:00
Event 19 of 22 = 05/15/2008 10:50:00
Event 20 of 22 = 05/15/2008 10:52:00
Event 21 of 22 = 05/15/2008 10:54:00
Event 22 of 22 = 05/15/2008 10:56:00

Modify an event (Yes/No) [N] ?
System status:
05/15/2008 10:28:18 23.7 vb 27 øC aligned

Proceed with the deployment (Yes/No) [N] ? y ← Proceed with deployment
<05/15/2008 10:28:21> waiting for Event 09 of 22 @ 05/15/2008 10:30:00

05/15/2008 10:28:23 sleeping . . .
```

Figure F-19: <6> Resume Deployment

Offload Data <7> can be used at any point during the deployment to display data for completed samples. Re-run option <7> at the end of the deployment to see data for all samples.

```

Main Menu
Thu May 15 10:28:03 2008
<1> Set Time           <5> Change Schedule
<2> Diagnostics       <6> Resume Deployment
<3> Fill Containers   <7> Offload Data
<4> Sleep             <8> Contacting McLane
Selection ? 6

Offload/Display Data File
Thu May 15 10:32:20 2008
<1> Display data file
<2> Display backup EEPROM
<M> Main Menu
Selection ? 1

To copy the instrument data file to a disk file, initiate
your communication program's file logging command now and
then press any key to start the transfer. The instrument
data file will remain resident and is not erased by this
offload procedure.

Software version: PST-21E1.c
Compiled: May 14 2008 10:49:29
Electronics S/N: ML12294-02

Data recording start time = 05/15/2008 10:28:21
Data recording stop time = 05/15/2008 10:31:57

HEADER
-----

SCHEDULE
-----
Event 01 of 22 @ 05/15/2008 10:00:00
Event 02 of 22 @ 05/15/2008 10:08:16
...
Event 22 of 22 @ 05/15/2008 10:56:00
```

Figure F-20: <7> Offload Deployment Data (screen 1 of 2)

As shown in Figure F-21, deployment data for Events 01-09 displays because only these events have been completed.

```
DEPLOYMENT DATA
-----
Event 01
Scheduled start time: 05/15/2008 10:00:00
Event start time:    05/15/2008 10:00:00
Event stop time:     05/15/2008 10:00:25

      Aligned   Battery   Temperature
Start:   Y      23.7      24 °C
Stop:    Y      23.8      24 °C

Event 02
Scheduled start time: 05/15/2008 10:08:16
Event start time:    05/15/2008 10:08:16
Event stop time:     05/15/2008 10:08:41

      Aligned   Battery   Temperature
Start:   Y      23.8      25 °C
Stop:    Y      23.8      25 °C

...
Event 09
Scheduled start time: 05/15/2008 10:30:00
Event start time:    05/15/2008 10:30:00
Event stop time:     05/15/2008 10:30:25

      Aligned   Battery   Temperature
Start:   Y      23.7      26 °C
Stop:    Y      23.7      27 °C

Schedule was not completed.
System recovered early.
End of instrument data file.
Terminate file logging operation now
and press any key to continue.
```

Figure F-21: <7> Offload Deployment Data (screen 2 of 2)

**NOTE**

To redeploy the Sediment Trap, the electronics must be reset and/or the power cycled by disconnecting the battery pack.